



Window & Door Owners Manual

Revised: Sept 3, 2025

Table of Contents

Table of Contents.....	1
1 CHAPTER – High Performance Windows and Doors	1
1.1 Introduction	1
1.2 Window and Door Models	1
1.3 High Performance Window and Door Terms	4
2 CHAPTER – Planning and Design Considerations.....	9
2.1 Best Practices and Building Codes	9
2.2 Detailing and Install Planning	9
2.3 Heat Source & Overhang Protection.....	16
2.4 Moisture and Humidity	17
3 CHAPTER – Delivery.....	18
3.1 Delivery Day:	18
3.2 TRANSPORT ARRANGEMENT:.....	18
3.3 RESTRICTIONS & RESPONSIBILITY:.....	18
3.4 EQUIPMENT:	18
3.5 SAFETY, PREPAREDNESS & TIMING:	18
3.6 INSURANCE, OWNERSHIP TRANSFER & 90 DAY NOTICE:	18
4 CHAPTER – Installation	20
4.1 Storage and Protection During Construction	20
4.2 Pre-Installation Preparation	20
4.3 Window/door mock-up	21
4.4 Install the Frame	22
4.5 Finishing the Install	22

4.6	Mulling (Combining sets)	23
4.7	Field Glazing	26
4.8	Post-Installation Assessment and Commissioning	26
5	CHAPTER – Care and Maintenance	29
5.1	Important Considerations and Common Issues	29
5.2	Harmful Practices to Avoid	30
5.3	Adjustments	30
5.4	Cleaning Glass	31
5.5	Cleaning Wood, Cladding and Screens	31
5.6	Cleaning & Maintaining Sealing Gaskets	32
5.7	Restoration & Repair of Aluminum and Wood Surfaces	32
6	Supplemental: Tilt & Turn Windows (ELITE E92, T80 (discontinued), S68, SUMMIT C97, C108).....	34
7	Supplemental: Outward Opening Window (OPTIMA)	50
8	Supplemental: Tilt & Slide Window or Juliette Balcony Door (ELITE E92)	58
9	Supplemental: Lift & Slide with Interior Operable Sash (ELITE HS80)	66
10	Supplemental: Slide with Exterior Operable Sash (OPTIMA Eco)	73
11	Supplemental: Inward Bi-Fold Slide (ELITE HL92)	81
12	Supplemental: Outward Bi-Fold Slide (ELITE HV92)	100
13	Supplemental: Tilt Turn Balcony Door (ELITE E92).....	111
14	Supplemental: Side Hinge Entry/Balcony Door, Manual Lock (OPTIMA, Euro-Alu).....	119
15	Supplemental: Side Hinge Entry & Balcony Doors, Auto Lock (CAL)	130

1 CHAPTER – High Performance Windows and Doors

1.1 Introduction

This document is designed to be reviewed prior to receiving your order. It provides comprehensive guidelines for the receipt, storage, installation, commissioning, and maintenance of your windows and doors, ensuring optimal performance and longevity as engineered.

Unless otherwise specified, references to “product” or “windows & doors” in this manual apply to tilt-and-turn inward-opening windows, outward-opening windows, sliding and bi-fold doors, and entry/balcony side-hinged doors provided by VETTA. All measurements, unless noted otherwise, are in metric units.

This manual consolidates VETTA’s and its manufacturers' best practices, organized into the following sections:

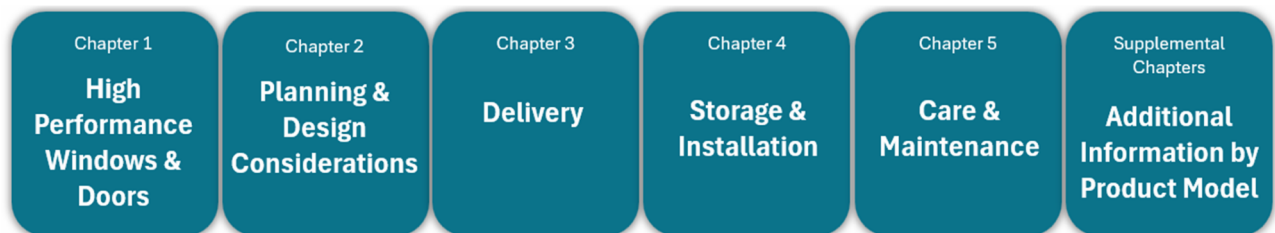

IMPORTANT: VETTA windows and doors are custom manufactured for your project. For intended performance, these products require robust framing, well-prepared openings, and precise installation to maintain plumb, level, and square positioning. Non-adherence to this manual’s guidelines will void the VETTA Product Warranty.

To ensure ongoing functionality and appearance of your VETTA windows and doors:

Review this manual thoroughly and carefully with your project team to integrate design and build requirements.

- A. Review this manual thoroughly with your project team to align with design and construction requirements.
- B. Engage qualified tradespeople with experience in high-performance window installation.
- C. Perform maintenance at the recommended intervals specified in this manual.

1.2 Window and Door Models

Before reviewing this manual, consult your VETTA order confirmation or the list provided below to identify the specific type of window or door purchased:

Tilt & Turn Window

Model: ELITE E92, T80*, S68 and SUMMIT C97 and C108
(*Discontinued in 2024)

Operation	Tilt & turn inward swing.
Hinges	Standard or hidden

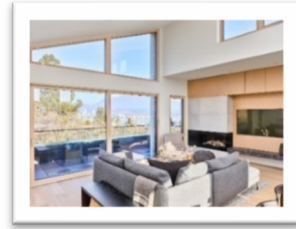

Outward Opening Window

Model: Optima

Operation	Outward swing
Hinges	Standard

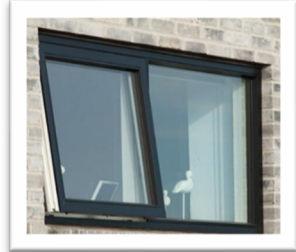

Tilt & Slide Window

Model: ELITE E92

Operation	Inward tilt & slide
Threshold	Wood, windowsill profile



Lift & Slide with interior operable sash

Model: ELITE HS80

Operation	Lift & Slide
Threshold	Aluminium & resin, low profile



Lift & Slide with exterior operable sash

Model: OPTIMA Eco

Operation	Lift & Slide
Threshold	Fiberglass, low profile



Inward Bi-Fold Slide

Model: ELITE HL92

Operation	Side hinge active sash connected to outward fold passive sashes
Threshold	Aluminium & resin, low profile



Outward Bi-Fold Slide

Model: ELITE HV92

Operation	Active man-door with foldable panels
Threshold	Aluminium, low profile

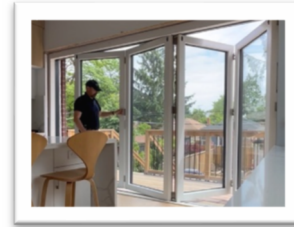

Tilt Turn Balcony Door

Model: ELITE E92

Operation	Tilt & turn inward
Threshold	Fiberglass/Aluminium, low profile



Hinge Entry & Balcony door

Model: OPTIMA and Euro-Alu*
(*Discontinued in 2022)

Operation	Inswing or outswing
Slab	Glazed or insulated core
Threshold	Fibreglass, low profile

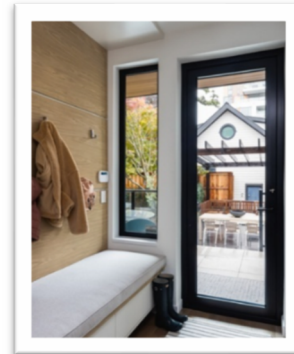

Hinge Entry & Balcony door with auto lock

Model: CAL Arctic, Presenta, Thermo

Operation	Inswing or outswing
Slab	Glazed or insulated core
Threshold	Fibreglass, low profile



Refer to vettawindows.com or contact your Vetta project manager for additional details.

High Performance Window and Door Glossary

Term	Definition
Adjustable	Accessible without major reconstruction to bring parts of the product to a true or more effective relative position.
Adjufix	A pre-mounted fastening system in window and door frames that allows precise alignment and secure wall anchoring, ideal for large or heavy units.
Air Barrier (AB)	A building component that restricts air movement between interior and exterior environments, improving energy efficiency.
Air Leakage	The flow of air that passes through fenestration products and building envelope.
Aluminum Cladding	A protective layer of aluminum applied to the exterior surfaces of windows and doors to enhance durability and resist weathering.
Argon Gas	Non-toxic gas placed between windowpanes to improve insulative performance
Astragal	A moulding attached to one of a pair of swinging double doors to cover the gap where they meet.
Awning Window	A window with a sash swinging outward from the bottom.
Bay Window	A combination window that projects outward from the exterior wall, typically with a large center unit and two flanking units at angles.
Casement Window	A window with a sash hinged outward to the right or left.
Casing	Exposed moulding or profile around a window or door, on either the inside or outside, to cover the space between the window frame or doorjamb and the wall.
Clerestory Window	A window set in a roof structure or high in a wall, used for daylighting.
Condensation	Moisture that accumulates on surfaces due to temperature differences: - <i>Interior</i> : Forms inside due to high indoor humidity and cold outdoor temperatures. - <i>Exterior</i> : Forms on the outside surface, indicating proper thermal insulation. - <i>Pane</i> : Forms between panes in IGUs, usually due to a broken seal.
Cross-Laminated Timber (CLT)	Engineered wood used in windows and doors for superior dimensional stability and durability.
Door Frame	The surrounding case into which a door closes, consisting of two upright pieces (jambs), a top piece (lintel), and a bottom piece (sill).
Door Slab	The door itself, without the housing frame or hardware. Can be a fully insulated panel, fully glazed, or a combination of glass and insulated panel.
Espagnolette	Locking mechanism activated through rotation of a handle, which moves a rod system to engage locking points at both the top and bottom of a door. It is commonly used to enhance security, weather sealing, and structural stability.
Exterior Cladding	Protective layer on window or door exteriors for durability, VETTA products utilize aluminum.
Exterior Windowsill	Horizontal ledge at bottom of window, to direct water away from the structure.
Fasteners (Mechanical)	Screws, bolts, or other hardware that secure windows and doors directly to the rough opening, providing structural stability and ensuring load transfer.
Fiberglass Threshold	The bottom step-over portion of a door frame made from fiberglass, designed for durability, weather resistance, and minimal thermal losses.
Fixed Window	A non-operable window that does not open, allowing light into the room.
Frame	Stationary part of window or door that encloses the operable sash or door slab

French Door	Typically, two hinged doors with large glass area where one or both swing open
Glazing Bars	Narrow, decorative strips dividing glazing unit into smaller sections. These can be purely cosmetic, as with internal glazing bars within the IGU, or structural, as with Vienna bars, which physically separate the glazing unit into smaller panes.
Head Jamb	The top horizontal part of a window frame.
Hopper Window	A bottom-pivoting window that opens by tilting vertically, typically to the inside.
Insulating Glass Unit (IGU)	Multi-pane window assembly that reduces heat transfer. Refers to the glazing, the gas fill, the spacer, and the edge seals.
Jamb	The vertical sides of a window or door frame.
Low-Adhesive Tape	Protective tape used to shield surfaces during construction, designed to avoid damaging finishes upon removal.
Low-E Glass	Glass with a low-emissivity coating that restricts heat loss.
Mulling	The process of joining multiple window or door frames into a unified assembly with seamless weatherproofing and air sealing.
Multipoint Locks	Locks that engage the sash or panel in multiple locations, typically using hooks, bolts, or cams which slot into corresponding keeps within the full perimeter of the frame. The multipoint locks are commonly activated through a single rotating motion (see also term espagnolette).
Muntin	Narrow strip of wood or metal separating and holding panes of glass in a window.
Operable Sash	Movable part of a window that allows for ventilation.
Picture Window	A large, fixed window in a wall, typically without glazing bars, providing an unimpeded view.
Plumb, Level, and Square	Alignment requirements for proper window and door installation to ensure optimal functionality and durability. Plumb: Refers to a surface or element being perfectly vertical. Level: Describes a surface or element that is perfectly horizontal. Square: Indicates that two-adjacent components or surfaces meet at a perfect 90-degree angle.
Rough Opening (R.O.)	The framed opening in a wall where a window or door is installed. It must be properly sized, plumb, level, and square to ensure secure fitting.
Sash	The operable part of a window or door that holds the glass and can move or be fixed in place. For door sashes containing no glass, this can also be called the slab or insulated panel.
Sealing Gaskets	Rubber or silicone seals used to prevent air and water leaks between movable and fixed components of windows and doors.
Sidelight	Vertical windows beside a door for added light.
Sill Pan	A sloped or flat base component installed under the window frame in the rough opening to direct water away and prevent leaks.
Skylight	A window built into a roof structure, allowing for natural daylight and moonlight.
Spacer (Warm Edge)	A material placed between IGU panes to separate them, minimize heat transfer, and improve insulation.
Stool	The interior trim piece that extends the sill of the window inward, providing a narrow shelf at the base of the window.

Sub-Sill Slope	A slight slope (usually 2% or 1/8":12") at the rough opening base to facilitate water drainage away from the window or door.
Threshold	The step-over bottom strip of a door to block drafts and debris.
Tilt-and-Turn Window	A versatile window that can tilt inward for ventilation or swing fully inward for maximum ventilation, cleaning, or emergency egress.
Transom	A transverse horizontal structural beam or bar separating a door from a window above it.
Transom Window	A window above a door, often fixed, providing additional light and ventilation.
Triple Glazing	Use of three panes of glass in a window to increase energy efficiency and provide other performance benefits.
UV Protector/Conditioner	A product applied to wood surfaces to protect against damage from ultraviolet light, such as fading, cracking, or drying.
Vapor Barrier (VB)	A building component designed to limit water vapor movement, preventing condensation within the wall assembly.
Warm Edge Spacer	Spacer that reduces heat loss around window edges.
Weather-Resistant Barrier (WRB)	A layer that protects the wall assembly from water infiltration while allowing vapor to escape, maintaining a dry building envelope.
Wheel Bogies	Rollers in sliding doors that facilitate smooth movement along tracks and require periodic cleaning and lubrication.
Window Frame	Stationary structure around the window, supporting glass and sashes.

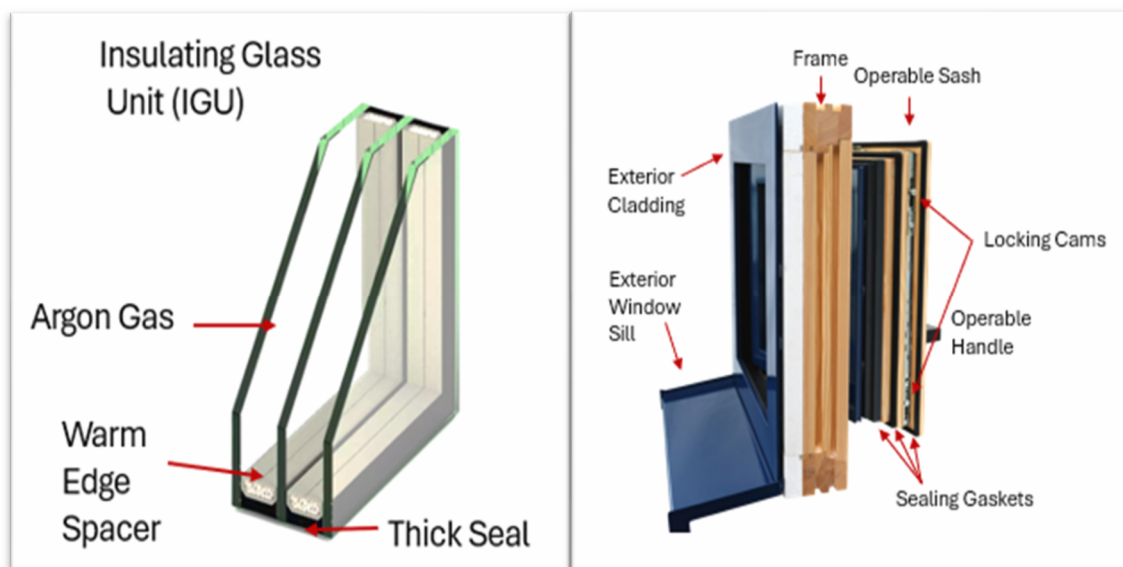

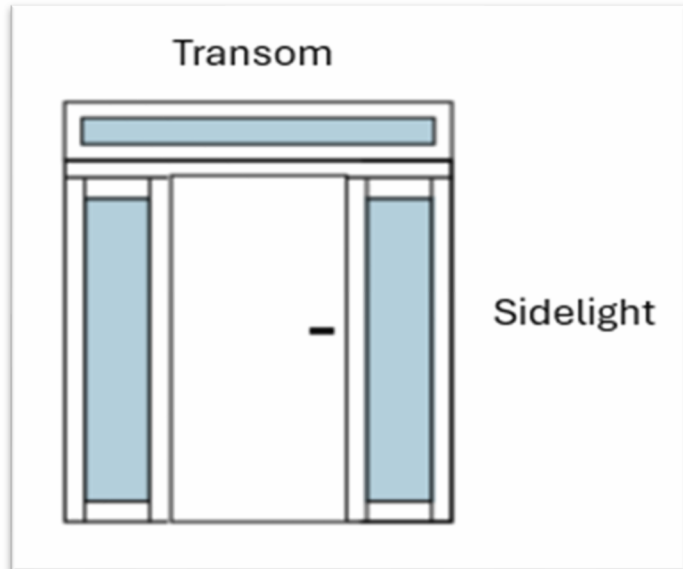
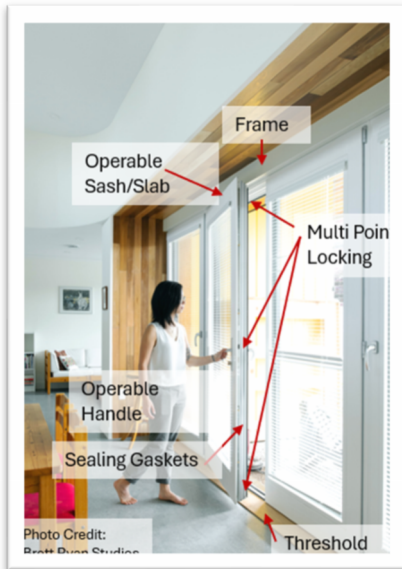
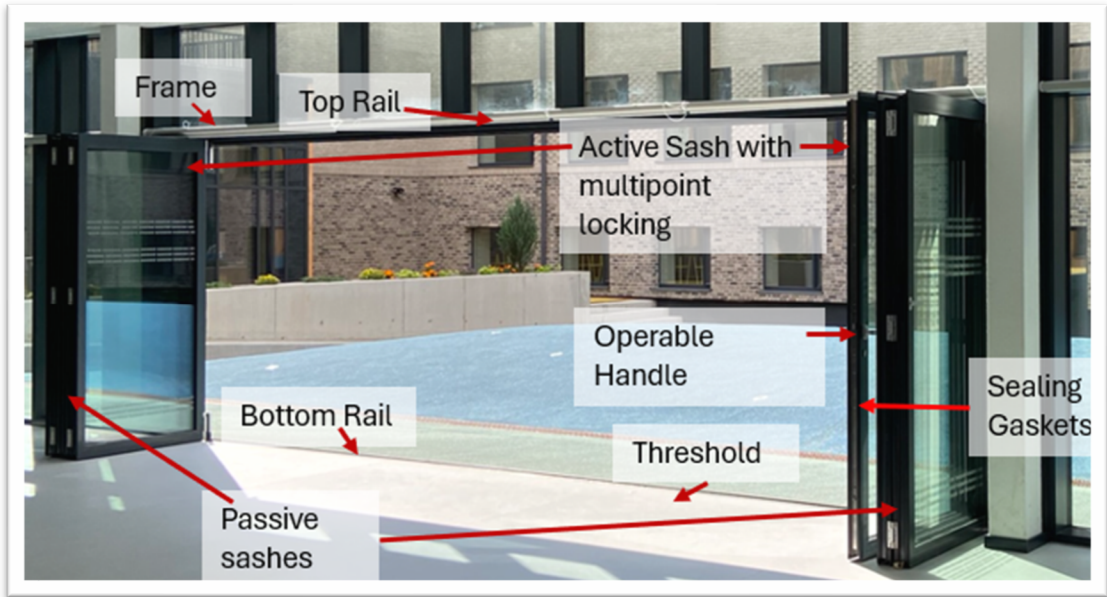

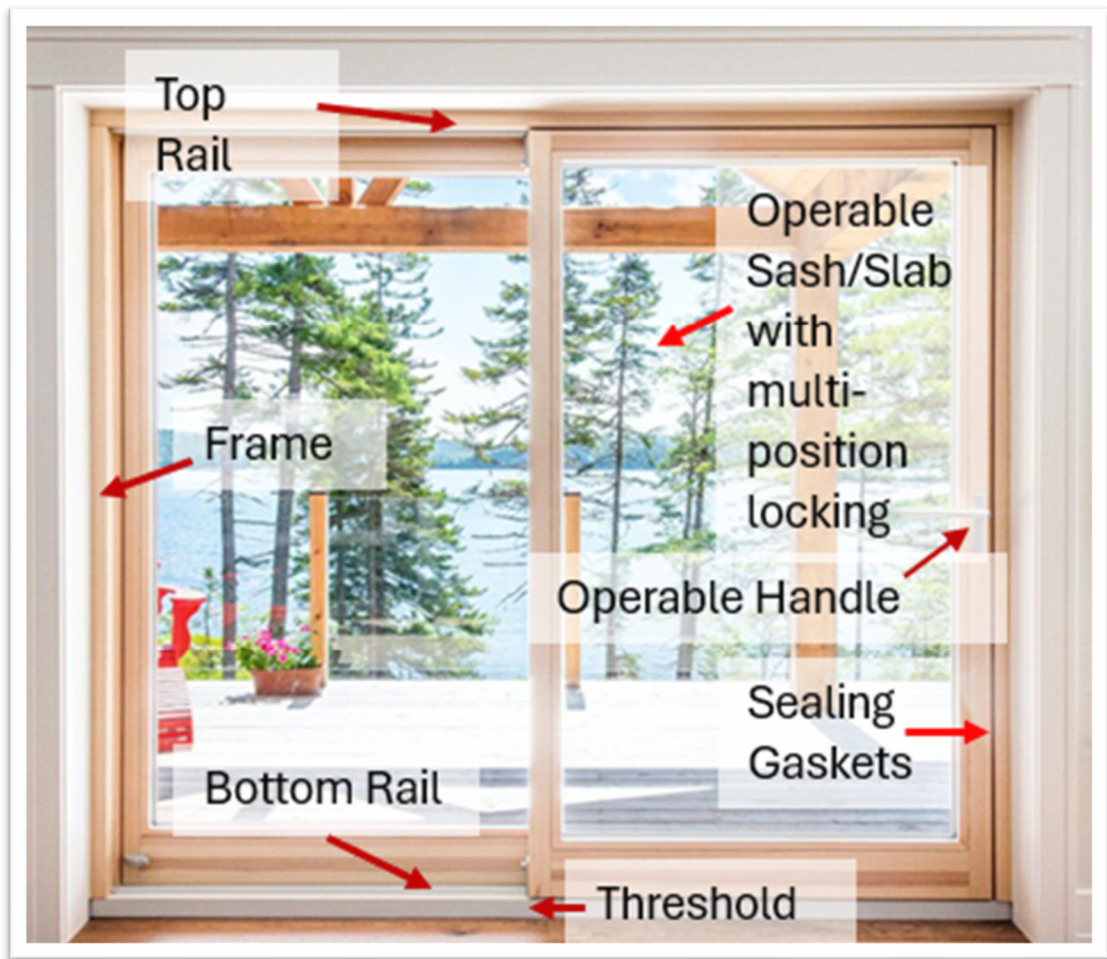

2 CHAPTER – Planning and Design Considerations

IMPORTANT: VETTA windows and doors are custom manufactured for your project. For intended performance, these products require robust framing, well-prepared openings, and precise installation to maintain plumb, level, and square positioning. Non-adherence to this manual’s guidelines will void the VETTA Product Warranty.

2.1 Best Practices and Building Codes

VETTA windows and doors, like other high-performance fenestration products, are more robust and heavier than standard models. The hardware and heavier components require a solid, flat, level base to support the entire product length. Regardless of construction method (stick-frame, prefabricated, ICF), attaching a window or door to an inadequately supported opening can lead to frame shifting, misalignment, and impaired function.

It is critical to follow local building code requirements and incorporate industry best practices for construction, such as those found in the Canadian Wood Frame House Construction Guide (CMHC). Additionally, selecting qualified builders and installers with experience in high-performance installations is essential. These professionals should adhere to the plans prepared by the architect/engineer and follow the guidance outlined in this manual to ensure proper installation and long-term performance.

Example diagram below from CMHC detailing window attachment to a properly framed window opening:

Window attachment

rough opening dimensions 25 mm (1 in.) larger than outside of window frame to provide a minimum 12.5 mm (½ in.) space between the window frame and rough opening

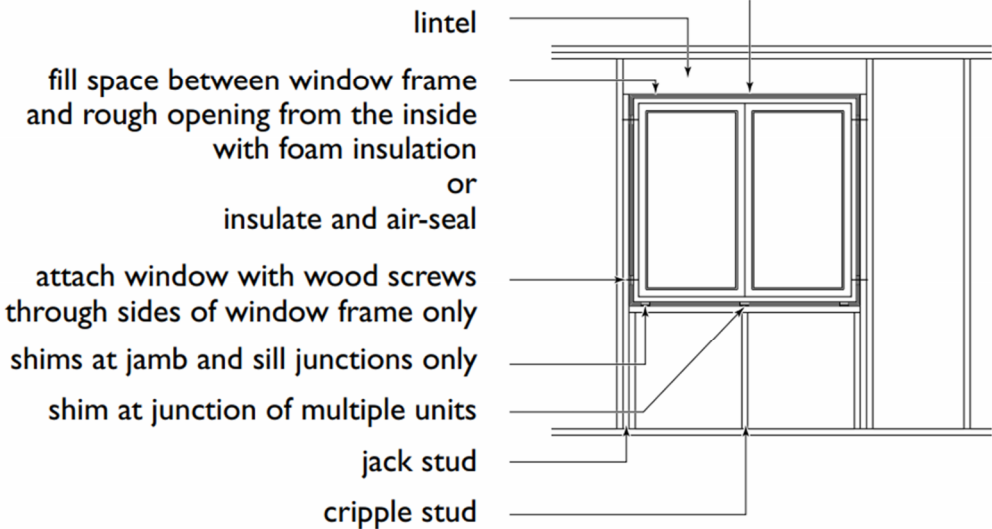

Note: Always refer to manufacturer's instructions.

2.2 Detailing and Install Planning

VETTA windows and doors are integral to the overall construction system. To ensure optimal performance, the consulting team must coordinate window and door details with other elements of the wall assembly. This team

may include a combination of the following: architect, builder, engineer, energy consultant, building envelope consultant, glazing contractor/installer, and code compliance officer/inspector.

Window Placement: Window placement within the rough opening should follow the consulting team's details or guidance, considering each product's specific requirements and the installation conditions. For optimal thermal efficiency, the center of the insulated glass unit (IGU) is often best positioned within the middle of the insulation layer to minimize thermal bridging between the window frame and wall assembly. Placement must also ensure adequate structural support, with proper bearing capacity along the entire length of the product and secure fixing points at the header and jamb.

The placement of the window within the wall will influence finishing details. For instance, door thresholds should align with the finished floor height to ensure proper clearance and seamless transitions. For operable windows, both inward and outward opening configurations require sufficient clearance around hinge hardware to allow for adjustments and prevent damage to finishes. It is recommended to plan finish materials and sequencing in advance to achieve the desired aesthetic and functionality. Additionally, consider sash positioning in the open state to ensure adequate clearance from fixtures, furniture, and pathways.

Rough Opening (RO): The rough opening—the space between the outer edge of the window frame and the framed opening—must be structurally sound, with a flat, level sill and square, plumb sides. The rough opening should typically be 5/8" larger on each side (1-1/4" total). In other cases, depending on membrane layering and adjustability needs, this may extend up to 1" per side (2" total), depending on membrane layering, tape use, and adjustability needs for larger windows or doors. At the sill, it is best practice to construct a sub-sill slope (typically 2% or 1/8":12") to ensure positive drainage of water away from the window. Rough openings may deviate from these guidelines for project-specific solutions; refer to the planning team's drawing details for any adjustments.

For renovation projects, existing rough opening measurements should be verified before ordering. In both new construction and renovations, clients bear responsibility for reviewing and approving final window and door dimensions; VETTA assumes no liability for incorrect measurements.

Fasteners and fixing points: Proper fastening of windows and doors is essential for structural stability, wind and live load transfer, and long-term operability. Along the length of the window and door frames, fixing points are established between the frame and wall structure. VETTA products can be secured with three main options:

Installation Anchor Straps: supplied with every order and commonly used for installation, installation straps are flat, durable metal brackets designed to secure windows within a rough opening. One end of the strap attaches to the window frame, while the other is anchored to the surrounding wall structure, providing stability and preventing movement. Straps allow for minor adjustments and help maintain alignment; particularly where direct fastening is not feasible. However, strap anchors alone are not recommended for large, hinged windows or door units, as they may allow movement over time. For added stability, supplement straps with mechanical fasteners directly through the frame and blocking into the structure. Refer to the supplemental chapters for model-specific strapping instructions.

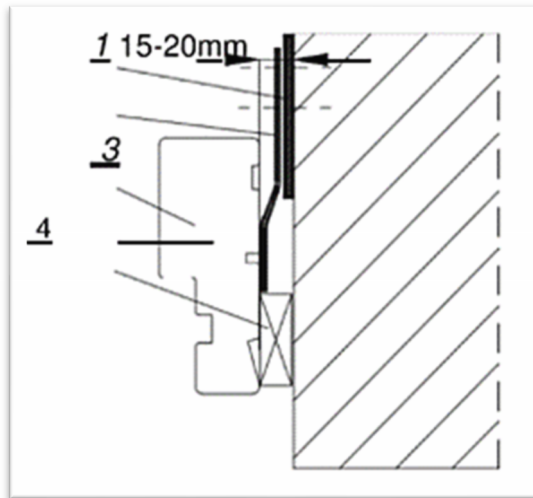

- #1 Steel anchor strap
- #3 Window frame
- #4 Support Block

Mechanical Fasteners: a durable screw or bolt that directly secures the window frame to the wall structure. It provides strong, stable attachment, ensures load transfer, and prevents frame movement, maintaining alignment and long-term operability. Pre-drill holes in the window frame prior to fastening to the wall assembly rough opening (location and spacing product dependent, consult with supplemental chapters for more details. Example below for mechanical fastener through an Optima-Alu frame.

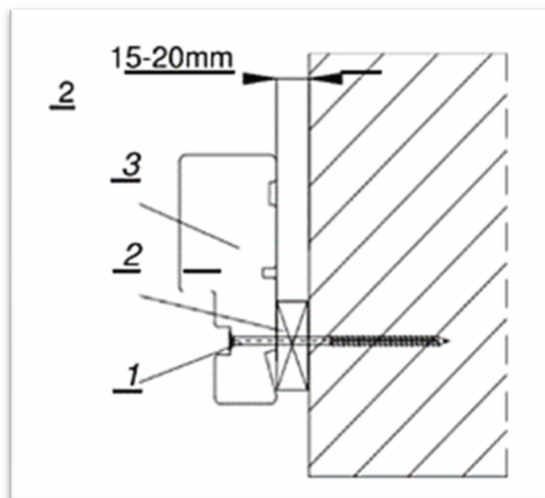

- #1 Mechanical Fastener (Screw)
- #2 Support block
- #3 Window Frame

Adjufix System: a fastening system for secure, adjustable window installation, featuring pre-mounted sleeves in the frame for precise alignment and reliable anchoring to the wall. It simplifies installation, reduces misalignment risk, and allows for adjustments to accommodate settling or structural shifts, ensuring long-term

stability and smooth operation. Often recommended for large doors or openings where access limits the use of straps or standard fasteners. Please note that adjufix is pre-installed at the factory and must be coordinated prior to ordering.

Using Adjufix Systems

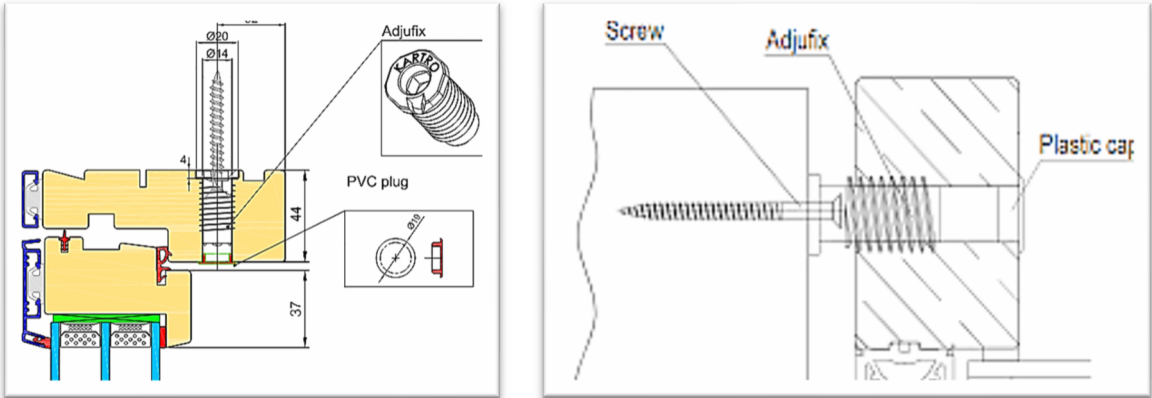
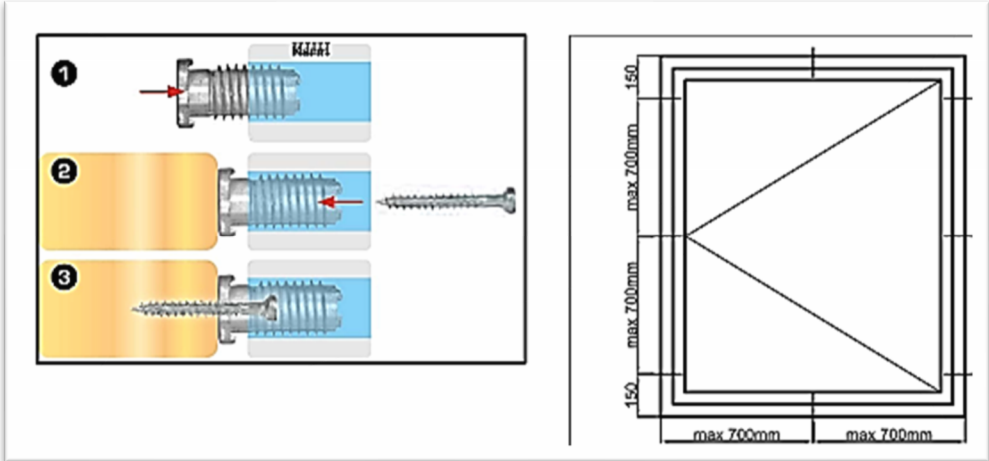

Refer to product-specific instructions for fastener specifications and fixing point locations. Incorrectly sized mechanical fasteners or improper fixing point installation may damage the product and void the VETTA product warranty. For any uncertainties, consult a VETTA project manager before proceeding with installation.

Blocking & Spacers: Window blocking provides structural support by establishing stable contact points between the window frame and the surrounding wall structure. This helps distribute the load from the window or door evenly to the building's structural frame, preventing undue stress or movement. Blocking maintains the alignment and stability of the window or door, supporting proper operation over time and reducing the risk of frame distortion or misalignment, especially for heavier or larger units. It also ensures that the weight of the window or door is effectively managed, contributing to the long-term integrity and performance of the installation. General blocking guidelines are provided below; refer to model-specific instructions for detailed requirements. While blocking materials may vary, it is recommended to use a non-rotting, incompressible

material.

- Block along the length of the windowsill or door threshold no more than 300mm apart.
- Ensure a block behind each of the hinges
- Block behind the latch on the frame
- Block 150 mm from corners

Blocking is required for large operable windows and hinged doors. It is recommended to install blocking behind hinges and latches and to secure mechanical fasteners through these locations.

Mechanical Fastener
Sealing gasket
Blocking (composite)

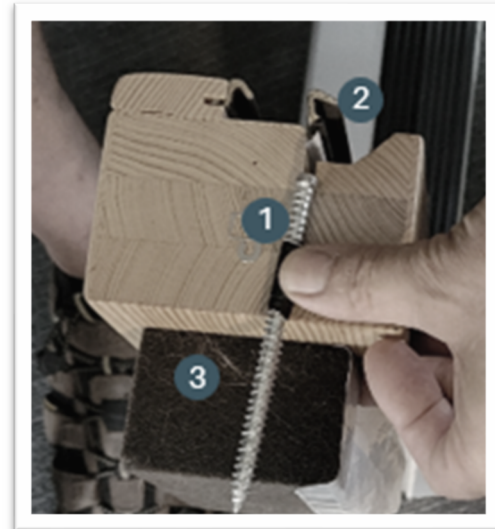

Sealing and Insulation: A complete wall system typically includes a weather-resistant barrier (WRB), air barrier (AB), and vapor barrier (VB). Ideally, connections between the frame and wall assembly should integrate all three barriers. Given the unique requirements of each project, it is the responsibility of the planning team (architect and builder) to coordinate and design installation solutions for VETTA products according to specific project conditions.

The rough opening must be prepared before installing a window or door. This may include applying a waterproof membrane at the sill and extending the wall assembly's air barrier into the opening to ensure continuity. Once the window or door is installed, further integration with the wall system is required. First, the gap between the heel of the window and the rough opening at the jambs and head should be filled with insulating material to reduce thermal losses. Next, the frame should be sealed to the wall assembly using high-performance tape or caulking, ensuring continuity of the WRB, AB, and VB. Consult the planning team for installation details and follow the instructions of supplier products for each specific condition.

The example below illustrates various tapes and membranes (Pro Clima products shown) used to create the weather-resistant barrier, air barrier, and vapor barrier around the window opening:

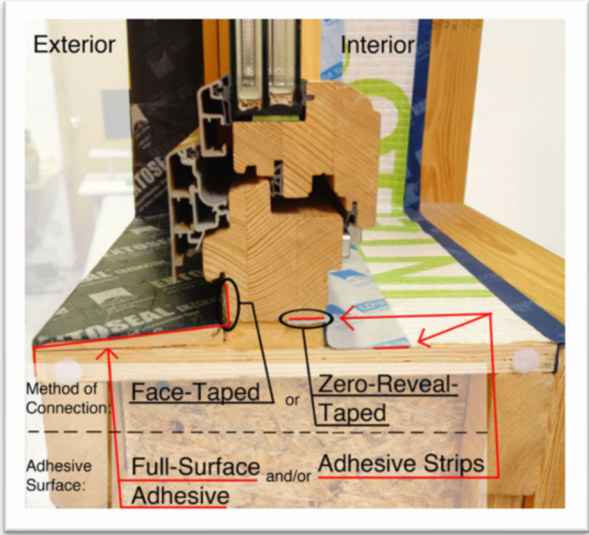

Drainage and Sills: VETTA windows and doors are engineered with an exterior drainage path between the aluminum cladding and wood frame to direct water away from the structure effectively. The installed flashings, sills, and lapped membranes must be designed to integrate seamlessly with VETTA products. To maintain proper drainage, do not obstruct this path at the bottom of the frame with trims or finishes, as doing so can cause water to flow back toward the interior. Each VETTA product has unique drainage conditions that should be coordinated by the planning team. Failure to keep the drainage path clear will void the VETTA product warranty.

All VETTA window products offer an optional, cost-effective, custom-made prefabricated aluminum sill solution from Aluron. These sills, constructed from heavy-gauge aluminum, are color-matched to the window, cut to width, and available in standard depth increments to suit any wall assembly. Fully integrated with the window frame, they ensure a watertight drainage plane and include end-dams that seamlessly integrate with the building's cladding details. Sill orders are coordinated by depth, profile, width, color and are placed simultaneously with window orders. Clients are strongly advised to with their consulting team to determine if this option is the right fit for their project. Projects opting to supply their own sill should consider all the principles mentioned above.

CLASSIC

THE CLASSIC SILL SYSTEM STANDS OUT WITH:

- Angular shape of profiles
- Varied width of window sills: 50 to 380 mm
- Extruded profiles of high rigidity
- A broad range of accessories, including sill support for thermo type facades

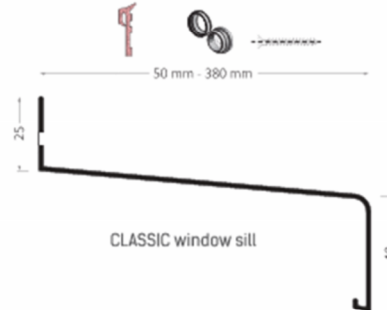
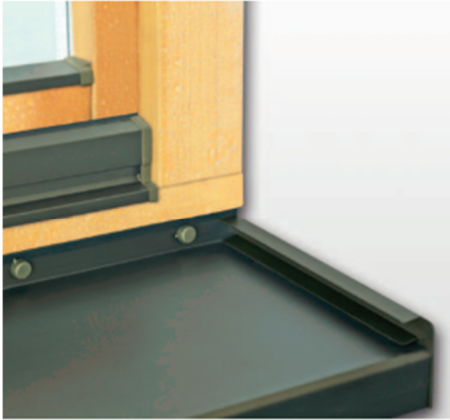

AVAILABLE SIZES:

	CAPS		Width [mm]																											
	Aluminium	Plastic	50	70	90	110	130	150	165	175	180	195	200	210	225	240	250	260	275	280	300	320	340	360	380					
CLASSIC	■		■	■	■	■	■	■	■	■	■	■	■	■	■	■	■	■	■	■	■	■	■	■	■	■	■	■		

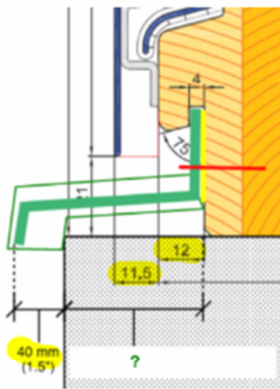

HOW TO CALCULATE YOUR SILL DEPTH:

WHEN CALCULATING SILL DEPTH, ENSURE THAT YOU ARE ALLOWING FOR THE ENCAP OVERHANG AND ALUMINUM CLADDING THICKNESS (HIGHLIGHTED IN YELLOW)

Aluminum Sill Dimensioning

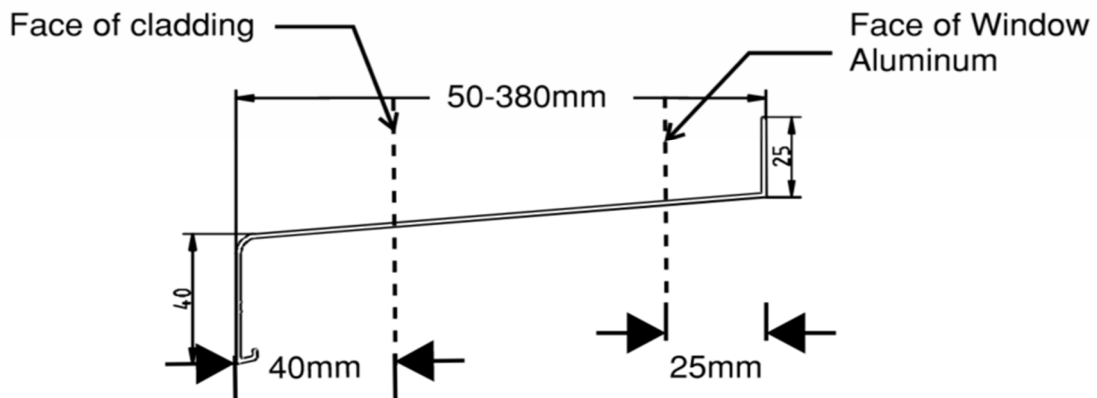

Refer to added details by window/door model in the Supplemental Chapters/Design Considerations.

2.3 Heat Source & Overhang Protection

Window and doors must not be installed within 1.5 m of a significant heat source, such as a radiator or fireplace.

Most VETTA windows and doors feature heavy-gauge exterior aluminum cladding. For models without aluminum cladding (e.g., certain CAL doors), exterior wood surfaces must be protected by an overhang to shield against elements and prevent damage to gaskets, operable mechanics, and surfaces.

Overhang requirements depend on window or door orientation and climate zone. At minimum, the overhang should extend beyond the outline of the open window or door and provide midday shading during winter. Also, determine the door's orientation (N, S, E, W). Southern-facing doors are especially vulnerable, as prolonged sun exposure can accelerate wear on wood exterior doors. Refer to the matrix below to find recommended overhang dimensions based on your local climate and door orientation.

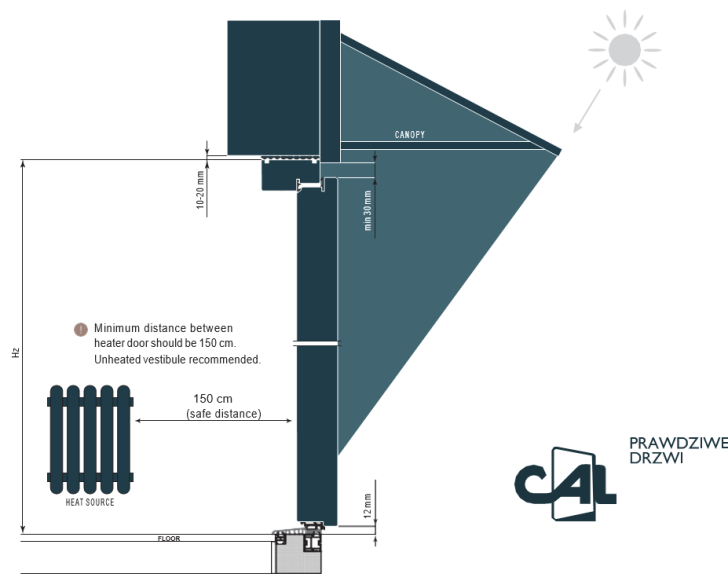

DIRECTION YOUR DOOR FACES

Climate	N	S	E	W
Mild	$X = 1/2 Y$	$X = Y$	$X = 1/2 Y$	$X = Y$
Wet	$X = Y$	$X = Y$	$X = Y$	$X = Y$
Ocean	$X = 1/2 Y$	$X = Y$	$X = 1/2 Y$	$X = Y$
Desert	$X = 1/2 Y$	$X = 2Y$	$X = 1/2 Y$	$X = Y$

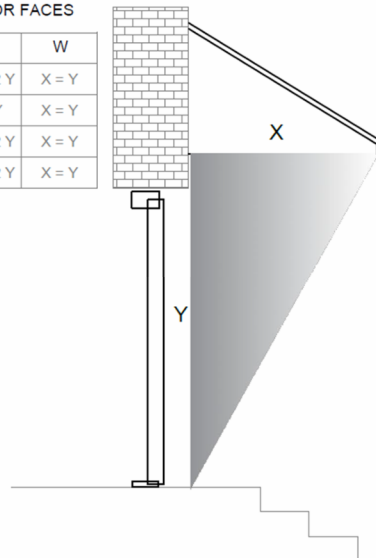

2.4 Moisture and Humidity

Maintaining appropriate indoor relative humidity (RH) levels is crucial for the longevity and performance of VETTA's engineered wood windows and doors. Although VETTA's cross-laminated timber (CLT) engineered wood products provide greater dimensional stability than traditional solid wood, exposure to ambient RH levels above 65% can lead to moisture absorption, resulting in expansion, contraction, warping, cracking, and potential blemishing of the finish. Such issues can impair the units' operability and appearance and may void your VETTA product warranty.

Recommended Indoor Humidity Levels: To prevent these problems, indoor RH should ideally be kept between 30% and 55%, a range that minimizes moisture-related risks while promoting comfort as recommended by Health Canada.

For installations in areas where RH may exceed 65%, consulting a VETTA project manager is recommended to assess product suitability in wet-area conditions, as VETTA may offer an all-aluminum window option specifically designed for high-humidity environments.

3 CHAPTER – Delivery

3.1 Delivery Day:

Having a well-organized delivery and unloading plan is essential to prevent product damage, avoid delays, and minimize additional costs. By reviewing the information below, the client acknowledges their responsibility for compliance with the stated requirements and assumes liability for any failure to meet these obligations.

3.2 TRANSPORT ARRANGEMENT:

The Client acknowledges that any shipment or transportation of the Order shall be conducted by a shipper of VETTA's choosing.

3.3 RESTRICTIONS & RESPONSIBILITY:

Deliveries cannot exceed 1400m elevation. Deliveries to residential areas are roadside only. You or your designate must be present at delivery. Designate cannot be the truck driver. You are fully responsible for the unload and to have appropriate labour, equipment (telehandler with 6' forks are recommended), snow removal and road blockage/traffic management, to ensure adequate safety for everyone. Individual pallet weight often exceeds 1000 lbs. Speak to your VETTA PM if you have questions about this shipping estimate or if you require delivery preparation guidance.

3.4 EQUIPMENT:

Default delivery, unless confirmed otherwise, is a tractor hauling a 53' trailer or 40' sea container. Transfer to a dedicated small truck or LTL (less than full load) courier service can be arranged where available. For driver operated equipment such as a tailgate, provided at an additional fee if feasible and available, can only be used for pallets 6' long or less and may require your assistance. A driver operated un-lowered tailgate may be used for longer pallets to make it easier for your equipment to reach the pallet, provided the trucking carrier permit it and the driver feels it is safe to do so.

3.5 SAFETY, PREPAREDNESS & TIMING:

If the driver considers the situation unsafe or is being harassed, or of you are unwilling or unprepared to receive the cargo, the driver will terminate the delivery, and you will be charged a return and redelivery fee. You are responsible to unload in the time allotted and leave no pallets/packing in the truck to avoid added fees. VETTA cannot guarantee delivery dates. We strive to provide the most accurate delivery dates but for many reasons such as statutory holidays, factory holidays, port congestion, labour conflicts, severe weather, customs delays, and shipping/train/truck equipment shortages can all effect shipping. If you are unable or unprepared to accept cargo when it arrives, or require a change to the delivery timing, location or equipment, additional fees will apply.

3.6 INSURANCE, OWNERSHIP TRANSFER & 90 DAY NOTICE:

Your cargo is fully insured to delivery, prior to unload. The driver will ask you to sign a Bill-of-Lading (BOL) which legally transfers ownership and responsibility from VETTA to you. Protect your rights by inspecting the cargo

before you sign the BOL. You are not expected to unwrap and inspect fully but if there are obvious issues at the time of unload, you must take photos and note these in writing on the BOL before signing and notify VETTA immediately so we can immediately begin to act. You have an additional 90 days from the delivery date to notify VETTA of damage that was hidden at time of delivery or items missing. For delivered items with product defect, please notify VETTA immediately and refer to the VETTA warranty for timing requirements.

4 CHAPTER – Installation

The following section serves as general guidance for installing VETTA products, covering key steps for a standard installation:

4.1 Storage and Protection During Construction

Storing VETTA Windows and Doors

After unloading, windows and doors should be stored safely, protected from external hazards, and kept in an environment where relative humidity does not exceed 65%, especially for extended periods. Carefully manage humidity levels, as there are many potential moisture sources, including curing concrete, drywall, tiling, and water-laden construction materials.

During storage, use soft spacers to separate windows and doors from each other and any supporting elements, with padding to prevent dents. Elevate products off the floor by at least 10 cm using horizontal wooden joists or pallets and store in an upright position to avoid hardware and coating damage. Do not store windows/doors in a flat, tabletop position.

Protecting VETTA Windows and Doors

Protect VETTA windows and doors from mechanical damage and contaminants such as paint overspray, drywall mud, stucco, cement dust, spray foam, and caustic chemicals.

- Do not run hoses or cords through openings.
- Avoid closing the sash/slab with any foreign objects inside, as this can damage coatings and seals.
- Shield windows and doors from welding spatter, open flames, excessive heat, grinding sparks, concrete, mortar, stucco, paint, and other harmful construction materials or processes, as these can permanently damage both the frame finish and glass surface.
- If any contaminants meet the glass, remove them immediately to prevent lasting damage.
- Remove all protective film from aluminum products promptly after installation, as prolonged exposure to the elements can make removal difficult and may damage the product.

4.2 Pre-Installation Preparation

Before installation begins, confirm the following to ensure proper readiness.

- Window/door position and placement is correct.
 - Verify that similar seeming units have the correct glazing (including coatings and tempered glazing) in the designated positions.
 - Confirm the right or left-handed orientation of similar window/doors and ensure they are correctly positioned.

- Correct rough opening sizes per detail designed by the planning team, sufficiently large for adjustments and insulation.
- The wall opening is well supported, level, plumb, and square on all four sides.
- The wall assembly air, WRB, and vapor barriers are ready to receive the window or door products.
 - Confirm a sill waterproof membrane or sill pan is installed along the base of the rough opening, extended six inches up the sides to prevent water infiltration.
- All wall opening surfaces are thoroughly cleaned.
- Suction cups and grips on-site for installation.
- All anchor straps are on-site for installation.
- Sealing tapes and/or backer rod, and caulking are on-site for installation.
- All required mechanical fasteners are on-site for installation.
- Blocking and shim materials are on-site for installation.
- Determine if operable sashes will be removed from the frames to ease the weight of large units.
 - The window sash and door slab can be removed for the following reasons: including frame installation, site mulling, glass replacement, or hardware replacement.
 - For additional details, refer to the specific window/door model information in the Supplemental Chapters.
 - **IMPORTANT:** Due to the heavy weight of these products at least two people should handle sash/slab removal and installation to avoid injury or damage. After removal, place the sash/slab in a safe location, standing upright on a softer padded surface. Do not lay flat, in a tabletop position on the floor as that will damage the unit.

4.3 Window/door mock-up

A window/door mock-up is critical before full installation to verify alignment, fit, and component compatibility. Multiple product's and install conditions may necessitate additional mock-ups. Follow this checklist:

1. **Strap Anchors and Mechanical Fasteners:** If strap anchors are the primary installation method, refer to strap spacing diagrams in the supplemental chapters for the specific frame type. Straps are positioned 150 mm from the corners and spaced no more than 800 mm apart. Strap anchors should be pre-mounted and positioned correctly for secure attachment to both the window/door frame and wall assembly. Mechanical fasteners used with the straps must be tested for compatibility with both the frame and wall. Consider finishing details around strap anchors to prevent interference with later finishing work. Straps can be modified on-site as needed by grinding excess material or drilling additional holes.

When using mechanical fasteners as the primary fixing method, pre-drilling in the wood frame is required. Use the correct drill bit diameter, with fastener hole spacing no more than 800mm apart. At locations requiring reinforcement (such as hinge points), add solid blocking in between the frame to wall **particularly for doors**. Refer to the supplemental chapters for specific drilling locations for each product.

2. **Blocking and shims:** Check the thickness of the blocking material and shims to ensure a proper fit within the gap in the rough opening. Trim any excess shims protruding beyond the frame to simplify

finishing. Avoid over-shimming or over-blocking against the frame, as this can cause an inward bow and compromise the long-term operability of the product.

3. **Sill Termination:** Ensure the exterior sill terminates at the intended location to maintain both aesthetics and functionality, as improper positioning can affect drainage and weatherproofing. For projects with prefabricated sills, confirm proper alignment with the window frame and adjust the frame position so that the end-dam clears the face of the finished siding.
4. **Window/Door to Wall Integration:** Verify that all membranes, flashings, and weatherproofing barriers can connect seamlessly to the window or door unit using tapes or backer-rod and caulking (as specified by the planning team). Completing a thorough mock-up gives an early opportunity to identify and resolve any issues, helping avoid costly rework during full-scale installation.

4.4 Install the Frame

After completing the mock-up, pre-mount the straps to the window/door frames and insert the frame into the rough opening. Secure just enough straps at the corners to the wall assembly to support the unit's weight, then adjust the frame to ensure it is level, plumb, and square. Position shims around the frame as needed, focusing on the bottom sill and both sides, to keep the window/door evenly spaced within the opening. Insert solid blocks as required. Once aligned, tighten the remaining straps to the wall assembly, ensuring nothing has shifted. Avoid over-tightening, as this may warp the frame. Open and close the window/door to ensure smooth operation and check that it is securely aligned. Adjust as needed.

4.5 Finishing the Install

In a typical install, the required steps are listed below. These details are often dictated by the planning team's project specific detailing. In general circumstances, the guidance below should be followed.

- **Insulate around the Frame:** Fill gaps in the rough opening with low-expansion foam, batt insulation, foam tape, or mineral wool to enhance thermal performance along the window/door frame perimeter. *****Avoid overfilling to prevent frame distortion.***** Note that this insulation should not be relied upon to create weather or air seal barriers; its purpose is solely to improve thermal bridging at the frame-to-wall connection.

If using spray foam, it is recommended to moisten the wall surface before applying the foam and to lightly spray the foam surface with water. Moisture enhances the performance of PU foam. Once the foam has dried, trim any excess.

- **Apply Exterior Flashing and Weather Resistant Barrier Sealing:** Install flashing tape around the window/door perimeter, as this serves as the primary drainage plane. Apply flashing tape starting with the sides, then the top, and finally the bottom to direct water away from the frame. Finish by applying high-quality caulking along the flashing edges to create a continuous moisture barrier. **Important:** Ensure that the free-draining cavity behind the aluminum remains unobstructed by leaving the bottom unsealed. **Blocking drainage at the bottom can cause water pooling, leading to ingress and voiding**

VETTA product warranties. If there are any questions, contact a VETTA project manager to discuss sill details before proceeding.

- **Apply Air Sealing Details:** Seal the perimeter of the window/door frame with high-performance tape or backer-rod & caulking to create an additional airtight barrier and prevent drafts. Ideally, a continuous air barrier should surround the frame perimeter, allowing for a seamless connection from frame to air barrier.
- **Interior Trim and Finishing:** Fit interior trim, drywall, or casing around the window to complete the installation. Ensure that hinges have at least 9mm (3/8") of clearance from finishes to allow for adjustability and prevent damage. Use only neutral-cure sealant for finishing, as other types may damage the finish.
- **Cleanup and Protection:** Apply temporary protection to the window or door if construction work will continue around it to prevent scratches or damage. Avoid applying tapes or films directly onto the finished surface, as prolonged exposure can cause stubborn residue, discoloration, or damage. For doors, it is best to designate a single construction entry door and install the VETTA door as late as possible to ensure it remains in optimal condition.

4.6 Mulling (Combining sets)

In certain project designs, multiple frames may need to be mullered together to create a larger window or door assembly. Mulling windows and doors into combined sets involves joining frames to form a single, unified assembly with weather-resistant and airtight barriers. This process requires precise alignment, secure fastening, and careful sealing. In most cases, combined sets utilize a tongue-and-groove design to assist with alignment. Always refer to mulling drawings specific to your installation conditions, which your VETTA product manager should provide in advance. A general overview of the process is outlined below:



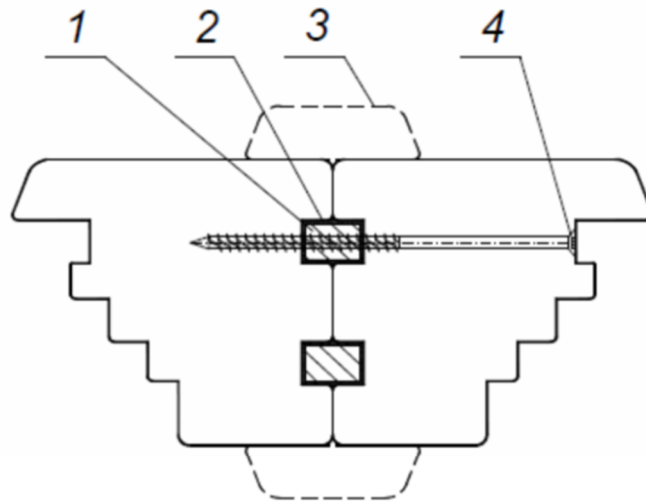

Fig. 8. Combining windows into sets

A – maximum screw spacing 500 mm,
 1,2 – connecting joint (tongue and groove) silicone,
 3 – cover strip (band),
 4 – wood screw

1. Preparation and Planning

- Review Manufacturer Guidelines: Refer to specific mulling instructions from the VETTA project manager including any attached drawings of the specific condition. Additional generic mullion details are contained in the supplemental chapters as well. Non-standard mullied sets may require review by engineer to specify structural screws and reinforcement stiffening profiles.
- Gather Materials and Tools: Additional tools for mulling include, appropriately sized wood screws, drill and drill bits, wood-working clamps, neutral-cure silicone sealant, aluminum trim pieces (supplied with order), rubber mallet.

2. Prepare Frames for Mulling

- **Operable Window/Swing Door Mulling:** Remove the sash and set it aside to connect the operable unit to the adjacent frame conveniently.
- **Fixed Window Mulling:** The factory typically ships the insulated glass unit (IGU) unglazed and secured with black temporary glazing clips.
 - Unscrew all black clips holding the glass, ensuring none are missed. Take care not to damage the IGU.
 - Carefully lift the IGU using suction cups and store it upright, on edge, on a soft surface such as rigid insulation or cardboard to protect the edge seals.

- Save the plastic glazing spacers, noting their positions, for final glazing.

3. Dry Fit and Align the Frames

- Position the frames in the designed configuration, ensuring that tongue-and-groove connections fit correctly.
- Perform this step in the rough opening or on a clean, flat work surface. Confirm proper fit and alignment. If necessary, modify tongues to ensure they slot into grooves properly.

4. Attach Straps and Aluminum Trim

- **Install Mounting Straps (if applicable):** Attach straps to the frames according to standard procedures, leaving straps out on the connection side.
- **Vertical Connections:** Pre-attach aluminum H-profile trim (S1-301) using a rubber mallet to secure it to the aluminum cladding. If the trim is not attached before mulling, cut off the smaller leg and adhere the trim with glue or 3M tape as an alternative.
- **For horizontal connections:** Set aside Gutman Z-22 aluminum trim for installation after final frame assembly. There is a cut running the width of the upper window which is ready to receive the Gutman Z-22 trim. Prep the Z-profile by pre-drilling the aluminum, applying a small bead of silicone to the face Z-profile aluminum contacting the wood frame, and fasten to the frame with small screws.

5. Final fit and Mulling the Units Together

- **Position Frames Closely:** Leave enough clearance to run continuous beads of silicone.
- **Apply Exterior Bead of Sealant:** Apply a continuous, large bead of neutral-cure silicone sealant along the mull joint, closer to the exterior face of the window. It is acceptable for the sealant to squish out, as it will be concealed by the H-profile trim. The exterior bead serves as the primary air and weather seal, so apply generously.
- **Apply Second Bead:** Add a smaller bead near the middle of the frame for added sealing. Clean any silicone that squishes out on the interior immediately.

6. Clamp and Align the Frames

- **Use Wood Clamps:** Secure the frames tightly, ensuring consistent gaps between the units.
- **Verify Gaps and Alignment:** Check that gaps are even from top to bottom (vertical) and left to right (horizontal). For larger mullion connections, clamps may not fully close the gap, relying on fasteners to pull the frames together.

7. Pre-Drill and Fasten Frames Together

- **Pre-Drilling:**
 - For operable units, pre-drill from operable frame toward the adjacent unit.
 - For fixed units, pre-drill from temporarily glazed frame toward the adjacent unit.
 - **Important: pre-drill only within the depth of the first frame, without plunging into the adjacent frame.**

- Space the holes no more than 500mm apart, starting 150mm from the frame's interior edge. Engineered connections may require specific spacing and staggered rows.

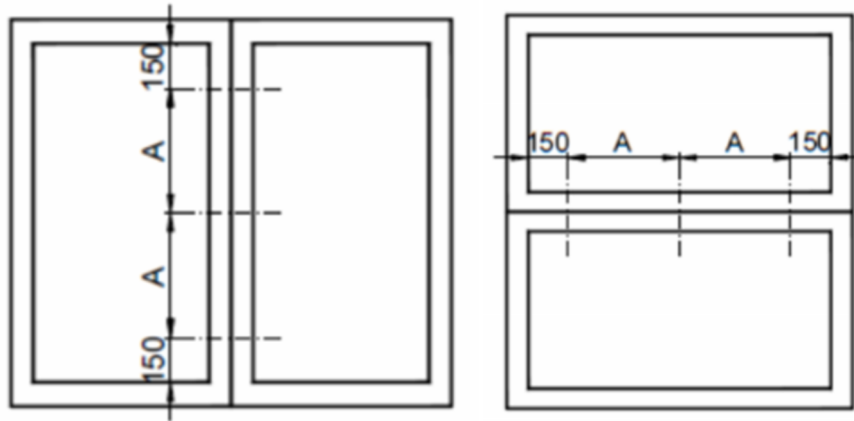

- **Insert Wood Screws:**

- Use appropriately sized wood screws, countersinking the heads slightly into the frame for a flush surface.
- **Important Note: The correct screw length and type vary depending on the mullion condition. Engineered connections may require structural screws as specified by an engineer.**
- Fasten along the frame length while clamping to ensure excess silicone squishes out to the exterior. Clean any excess silicone from the interior finish face.

- **Install the mullied assembly**

- Install the completed mullied assembly in the rough opening following standard window installation guidelines.

4.7 Field Glazing

For field glazing, see supplemental chapters for specific instructions on each VETTA product.

4.8 Post-Installation Assessment and Commissioning

VETTA windows and doors are factory-inspected, CNC-machined, and pre-adjusted for quality and functionality before leaving the factory in Poland. In 99.9% of cases, operational issues after installation are due to the rough opening (RO) or installation not being level, plumb, or square. In extreme cases, header deflection above openings can apply excessive load to the window frames, causing total window function failure. Additional on-site adjustments may be required after installation, particularly as buildings settle and dry.

IMPORTANT: The property owner and installer are responsible for assessing and performing any necessary adjustments. Installations that are not precisely plumb, level, and square—within a tolerance of 1.5 mm (1/16 inch) on both vertical and horizontal planes—can hinder smooth operation. Operational issues and hardware damage caused by improper installation are not covered by VETTA product warranties. If a unit becomes difficult to operate, discontinue use to prevent further damage, and avoid using extreme force.

Common Causes of Misalignment and Operational Difficulty

- **During Installation:** Inadequate blocking, over-blocking/shimming, insufficient fixing points, no wood screws at hinge points lead to the entire frame shifting through usage.
- **External Factors:** Building settling, improper use, damage, or debris buildup on hardware can push the unit out of alignment. Loose or overtightened adjustments on the hardware can also contribute to operational issues.
- **Rare Factory Defects:** In exceptional cases, the factory may have sent a defective sash or door slab with a bow. If this is suspected, contact a VETTA product manager immediately for instructions on submitting a warranty claim.

Pre-Assessment

- **Check Moving Parts:** Inspect for loose connections or signs of wear caused by friction. Tighten screws as needed and notify VETTA for replacement parts if defective.
- **Assess Alignment:** If operational issues persist and adjustments are insufficient, assess the unit's alignment ("trueness") with the following tools:
 - 6-foot (180 cm) level or laser level
 - Tape measure or digital tape measure
 - Step stool/ladder
 - Pen, paper, or phone camera for documentation

Measurement Guidelines

Record the following measurements in millimeters with the window or door open:

- **Diagonal Measurements:** Measure top-left to bottom-right and top-right to bottom-left.
- **Horizontal Measurements:** Take five evenly spaced measurements from the threshold to the top.
- **Vertical Measurements:** Take five evenly spaced measurements from left to right.
- **Plumb and Level Checks:** Take 2 to 5 additional measurements to confirm plumb and level (shown in blue below).

Important: Any measurement differing by more than 2-3 mm (1/8 inch) indicate that the window or door is not plumb, level, or square and may not operate correctly.



5 CHAPTER – Care and Maintenance

5.1 Important Considerations and Common Issues

Proper maintenance, cleaning, and adjustments are essential to ensure the long-term functionality and appearance of VETTA windows and doors. This section outlines consolidated guidelines for general upkeep, hardware, care, and adjustments. A table below is provided for the most common problems.

Common Issues

Issues / Symptoms	Likely Causes (& Remedies)
A window / door will not open / close properly	<ul style="list-style-type: none">• The unit is not plumb, level, or square (refer to previous section).• Debris buildup, damaged gasket or hardware, or insufficient lubrication.• Wood swelling has occurred (see below)
Moisture swelling in the wood	<ul style="list-style-type: none">• Wood swelling due to prolonged periods of high humidity. Limit usage to avoid permanent damage to gaskets and hardware until humidity levels normalize or make temporary adjustments.• Inadequate management of indoor humidity levels (<i>refer to Section 2.4</i>).• Exterior drainage path is blocked, preventing proper drainage and causing water to pool and ingress (refer to sill details in design Considerations section).• Inadequate, punctured, or degraded weather resistant barrier and vapor controls around the window/door or building façade.
Condensation on glass	<ul style="list-style-type: none">• Interior condensation that can be wiped off is caused by high indoor humidity combined with cold outdoor temperatures (refer to Section 2.4).• Exterior condensation that can be wiped off indicates proper functioning of the glass unit.• Condensation within the panes of insulated glass or a fogged glass unit suggests a broken seal. If this occurs, notify VETTA, as a replacement may be necessary.

Maintenance Guidelines

- Regularly inspect moving parts for loose connections, wear, or damage. Tighten loose screws, make needed adjustments, and notify VETTA for defective parts replacement.
- Examine exterior surfaces for scratches, chips, or abrasions, and notify VETTA promptly to prevent further deterioration.
- For smooth operation of slides and bifold, inspect the slider tracks for buildup and remove accumulation of debris. Should debris be inaccessible, remove the panels from the track and thoroughly clean the wheel bogies. On sliders thoroughly clean both the bottom and top rail, to remove dust and debris, as well as clean and lubricate the wheel bogies at the bottom. (Refer to Supplemental Chapters for sliders and bifold for safe removal instructions).

Cleaning Guidelines

- Prevent the accumulation of contaminants such as sand, salt, dirt, and debris on exterior surfaces, tracks, thresholds, gaskets, on operable hardware, as these can interfere with smooth operation.
- Clean thoroughly before lubrication, ensuring hardware in frames, sashes, thresholds, and slide tracks is free of dust and debris.
- Use only non-abrasive cleaning methods to avoid damage to surfaces, seals, and gaskets. Harsh cleaning products and pressure washers must not be used, as they can damage components, including insulated glass seals, hardware, and finishes.

Lubrication

- Lubricate all moving parts, including the locking components as well as the keeps with clean, non-resinous grease or oil (e.g., 3-in-1 Oil).
- For slides and bifold apply silicone lubrication inside the slide tracks to facilitate smooth operation
- Perform lubrication as part of routine maintenance to minimize wear and reduce friction of operation.

5.2 Harmful Practices to Avoid

To prevent damage and maintain proper functionality:

- Do not insert objects between the frame and sash to force or block closing.
- Avoid slamming windows or doors, whether intentionally or due to wind.
- Do not forcefully operate doors or windows which are out of adjustment.
- Do not hang heavy objects on the handles of sashes or the operable sashes themselves when opened.
- Refrain from using pressure washers or harsh cleaning products that can damage seals, hardware, and finishes.

5.3 Adjustments

Frequency: As needed

Adjustments may be necessary over time to maintain optimal performance, particularly during the first year of a building's life cycle as settlement occurs and materials dry out. Seasonal changes can also create the need for periodic adjustments. While installers may provide adjustments within their own warranty terms, **ongoing adjustments are the responsibility of the homeowner or property owner** and are **not covered under VETTA's warranty**. Adjustments are a normal part of maintaining the product and do not constitute a defect.

- For model-specific adjustment instructions, refer to the Supplemental Chapters.

- After adjusting, check for proper functionality. If issues persist beyond normal adjustments, contact VETTA for further guidance.
- If the homeowner or property owner prefers not to perform adjustments themselves, they may hire their builder, installer, VETTA service, or another qualified professional to handle the adjustments.

5.4 Cleaning Glass

Frequency: As needed

- **General Cleaning:** Never use a pressure washer. Use a mild, pH-neutral cleaning product with a clean, soft cloth or squeegee.
- **Avoid Harmful Cleaners:** Do not use caustic or alkaline cleaners, abrasive powders, or other harsh products on glass surfaces, as they can cause damage.
- **Glass Cleaners:** Most glass cleaners contain ammonia. After cleaning, remove ammonia residue with clean water and a soft cloth.
- **Stubborn Stains:**
 - For glues, rubber residue, or adhesive tape residue, use a heavily diluted, non-petroleum-based solvent, such as Earth paint Pure Citrus Solvent
 - Oily or tarry stains can be dissolved with organic grass-fed butter.
- **Handling Solvents:** Solvents can damage insulated glass, aluminum, or wood surfaces. Use sparingly, apply carefully, and remove thoroughly with water promptly.
- **Plaster, Grout, or Cement Removal:** Moisten glass with water before attempting to remove these substances.

Warning: Improper cleaning methods or prolonged exposure to harsh substances can permanently damage materials. Always proceed with caution and test on inconspicuous areas when using new cleaning products.

5.5 Cleaning Wood, Cladding and Screens

Frequency: Twice a year, preferably spring and fall

- **Temperature Consideration:** Perform cleaning when the outdoor temperature is below 25°C as higher temperatures may cause rapid drying of cleaning solutions and reduce effectiveness of cleaning agents.
- **General Cleaning:** Thoroughly clean windows, doors, and any buildup around the silicone seal at the glass perimeter to remove dust, insect stains, and dirt. This prevents degradation of the seal and discourages the growth of mildew and fungi. Use warm water (never hot) with suitable cleaning products as outlined below:

Specific Surface Cleaning Instructions:

- **Aluminum surfaces and insect screens:** Use a mild or slightly alkaline cleaning product. Avoid solvents containing esters, ketones, alcohols, aromatic compounds, glycol esters, or chlorinated hydrocarbons.
- **Wood Surfaces:**
 - Clean with a soft, slightly damp cloth.
 - Use a gentle cleaning product designed specifically for finished wood. No acidic based cleaners are allowed as that will degrade the finish.
 - For woods heavily exposed to sunlight, apply a UV protector or conditioner.
Recommended products include:
 - Ottimo Window Profile Cleaner and Conditioner Kit (available from VETTA).
 - Howard Clean-A-Finish and Howard Sunshield Conditioner (available at hardware and woodworking stores).
- **Stubborn Stains:**
 - Dissolve oily or tarry stains with organic grass-fed butter.
 - For glue, silicone, or adhesive tape residue, use a heavily diluted non-petroleum based citrus solvent, such as Earth paint Pure Citrus Solvent.

Warnings:

- Solvents can damage insulated glass, aluminum, or wood surfaces. Use sparingly and carefully. Do not leave solvents on surfaces unattended. Always remove them thoroughly with water.
- For removing plaster, grout, or cement mortar, moisten the glass with water before cleaning.
- **Final Steps:** Rinse all surfaces immediately after with clean, cold water and dry with a soft cloth. Avoid abrasive cleaners or pads, which can damage aluminum and wood finishes.

Following the described cleaning methods ensures effective cleaning while preserving the integrity and appearance of all surfaces.

5.6 Cleaning & Maintaining Sealing Gaskets

Frequency: Once a year

Clean gaskets help ensure a tight seal between the sash and frame. Use mild soap and warm (not hot) water to clean the gaskets, then dry thoroughly. To recondition the gaskets, apply a small amount of silicone spray to a cloth and wipe the gaskets; avoid spraying directly to prevent overspray from affecting the window or door finish. Keep a shop towel or rag nearby to clean up any excess silicone. Damaged gaskets should be replaced—contact VETTA for replacement parts.

5.7 Restoration & Repair of Aluminum and Wood Surfaces

Frequency: At a minimum, after 3 years, and annually after

Exterior wood surfaces should be inspected at least every three years and annually thereafter. Signs of

wear, such as chips, cracks, or peeling, indicate the need for restoration painting or staining to protect the wood from direct weather exposure. The windows and doors are factory-coated/ finished with water-soluble acrylic paints & stains, so any restoration finish must be compatible with the existing coating. Contact VETTA for touch-up stain or paint.

After a hailstorm, it is essential to inspect the surface for damage caused by ice impact. Cracks, chips, or peeling in exterior aluminum cladding should be repaired immediately to prevent further deterioration. Before beginning any painting, clean the surface thoroughly as outlined in this chapter and ensure that all hardware and gaskets are protected from accidental paint coverage.

Painting should only be performed when temperatures are above 8°C and humidity is below 65%. During construction or renovation projects, wood windows and doors must be shielded from construction materials using low-adhesive tapes suitable for wood surfaces. These tapes should be removed promptly, as prolonged application may cause damage to the wood finish.

Adhering to these maintenance practices will preserve the appearance and durability of the wood surfaces over time.

6 Supplemental: Tilt & Turn Windows (ELITE E92, T80 (discontinued), S68, SUMMIT C97, C108)

IMPORTANT: Review Chapter 1 before reading the additional supplementary information below.

6.1 Operation

Tilt & turn windows have four main configurations (with Tilt & Turn most prevalent): - tilt and turn, tilt before turn, tilt only and turn only.

Tilt & Turn Window

- (1) Closed and locked
- (2) Turn mode
- (3) N/A
- (4) Tilt mode

Tilt before Turn Window

- (1) Closed and locked
- (2) Tilt mode
- (3) Turn mode

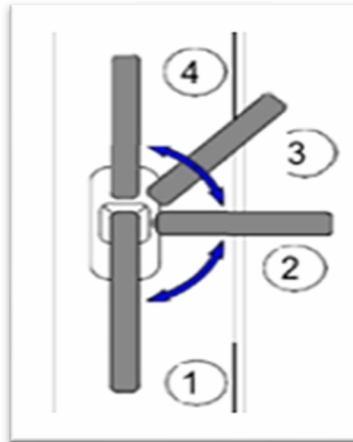

Tilt Only Window

- (1) Tilt Mode
- (2) Closed & locked

Turn Only Window

- (1) Closed & locked
- (2) Turn mode

Flying Mullion - The window has two operable sashes: an active sash and a passive sash. To open the active sash (the one with the handle), turn the handle 90 degrees and swing the sash open. To open the passive sash, disengage the locking lever to release it, then swing it open.

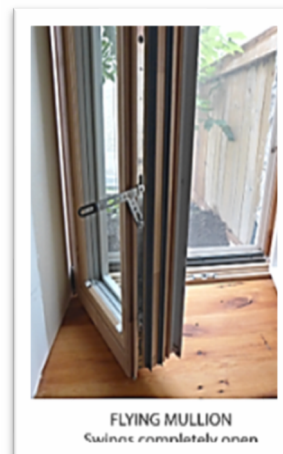
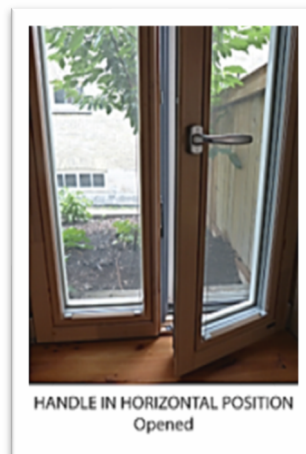

Tilt & Turn

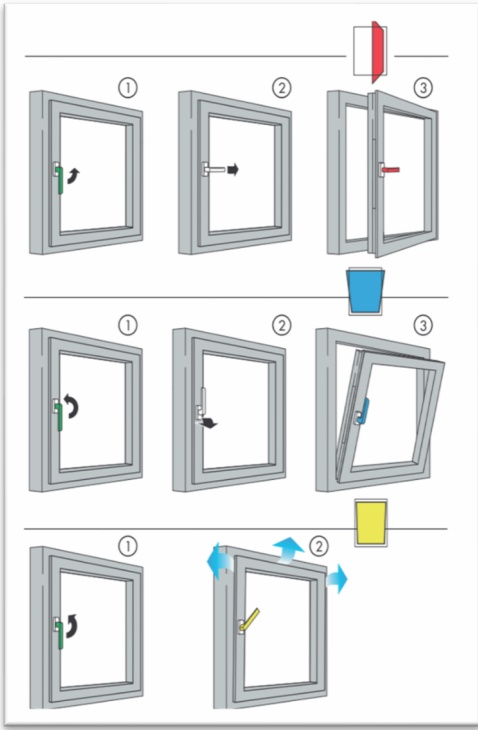

Tilt Before Turn

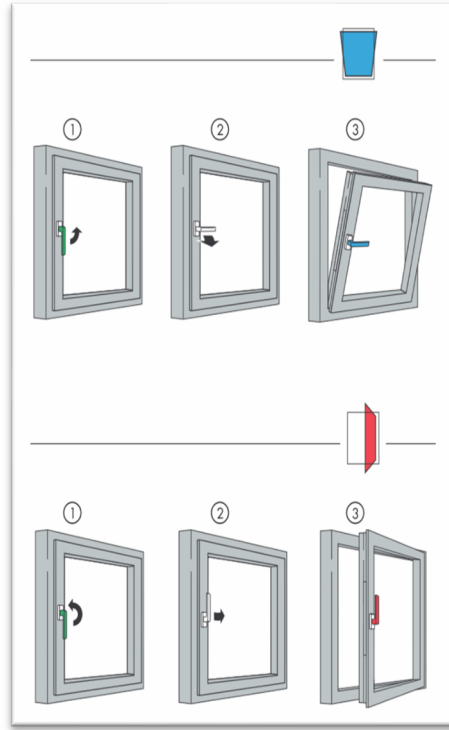

Tilt Only

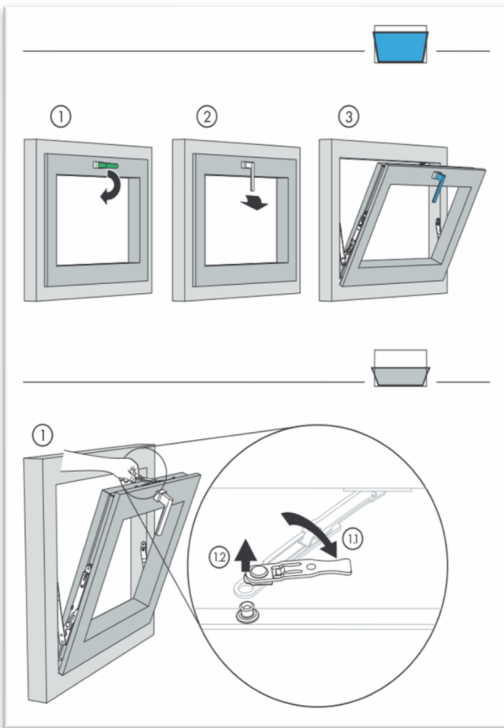

Fixing Common Operation Errors

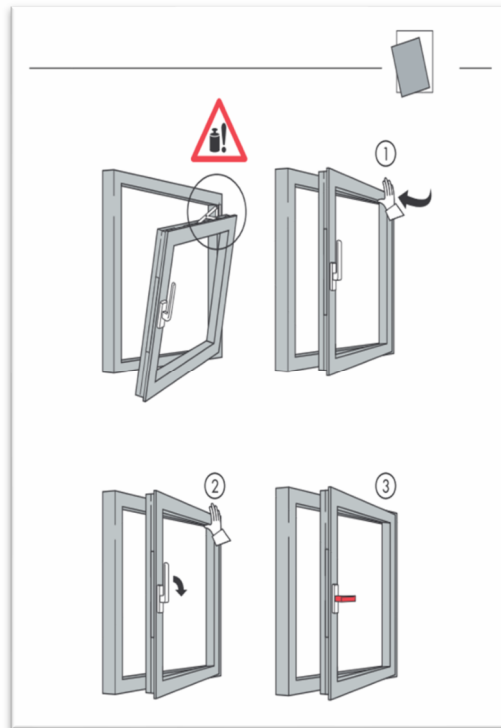

SUMMIT Windows (C108, C97)

For prefabricated sill installations, Gasket AU1681 is provided and must be installed together with the sill.

To ensure a proper seal, Gasket AU1681 must be correctly positioned on the sill, as shown in the diagram (location indicated by the green circle). When the sill is fastened to the frame, the applied force compresses the gasket, forming a watertight seal.

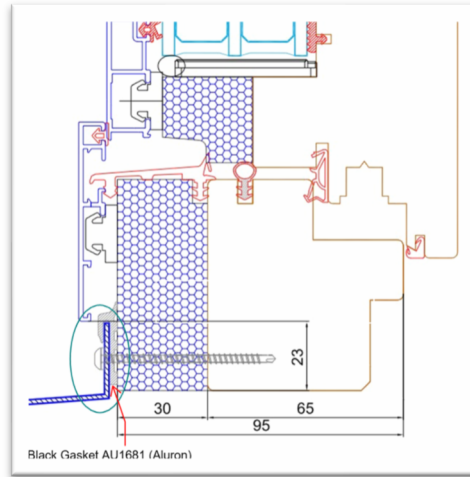

Strap Anchor Fixing Points

A - Max 800mm

E - 150mm (measured on inside of frame)

I - Fixing point

■ - Block

□ - Support block spacer

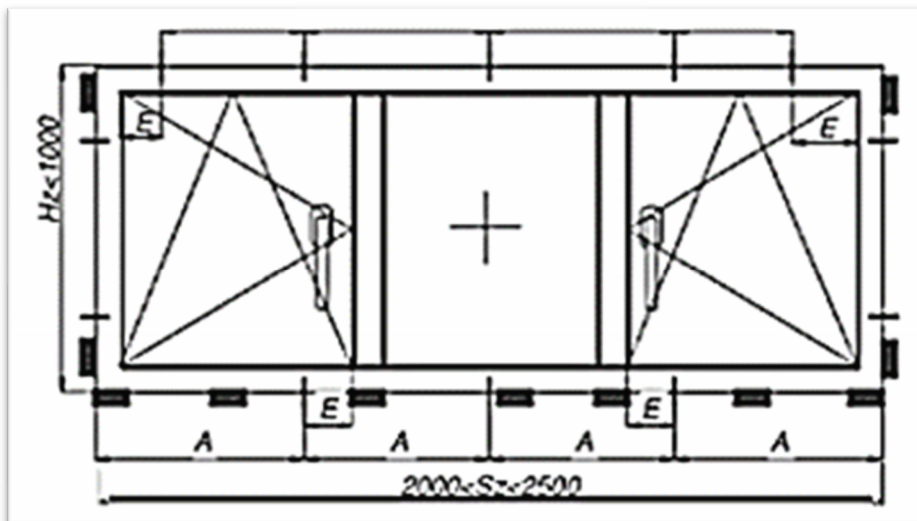
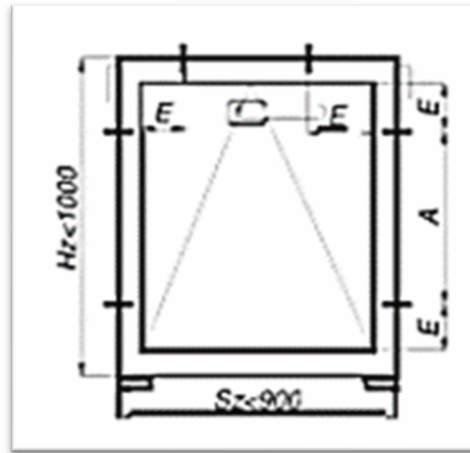

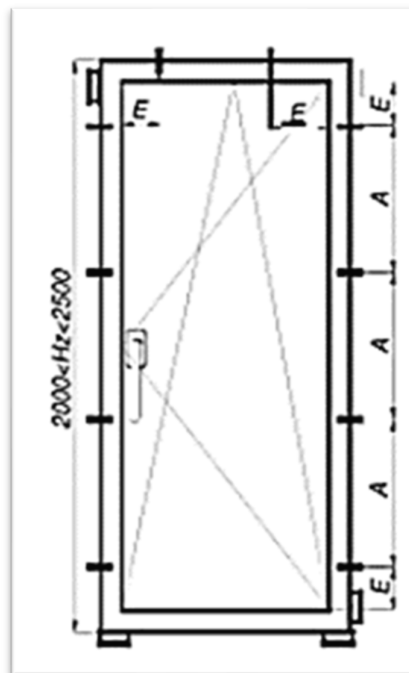
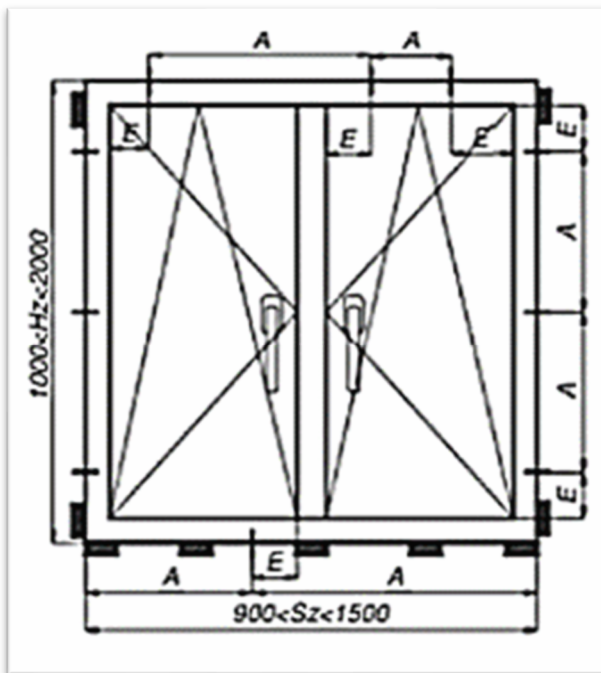
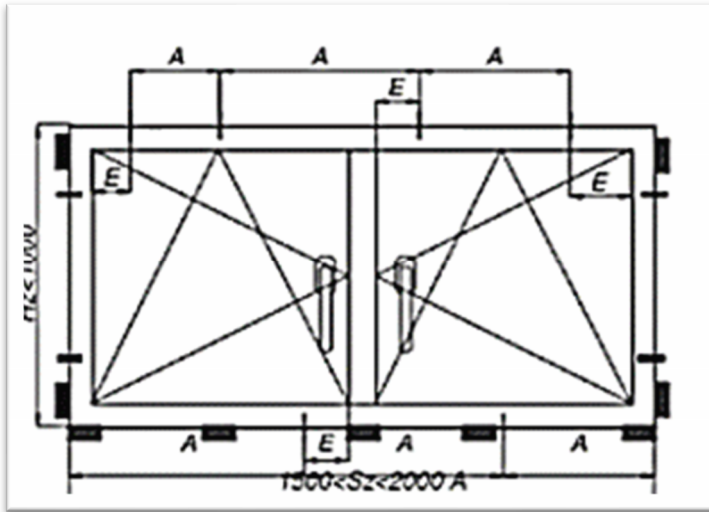

6.3 Tilt & Turn Sash Removal and Install

IMPORTANT: Review Chapter 5 and Chapter 6 before proceeding.

To remove the hinge cover, gently pry it open by placing your fingernail behind the cover, then pop it out and lightly squeeze to release it.

Step 1: To remove the top pin, use the construction handle supplied with your order.

As shown in the diagram on the right, press down on the pin using the construction handle—this will cause the pin to pop out of the hinge at the bottom. Then, pull the pin downward to fully remove it.

NOTE: Store the pin safely, and when reinserting, always insert it from the bottom, not the top.

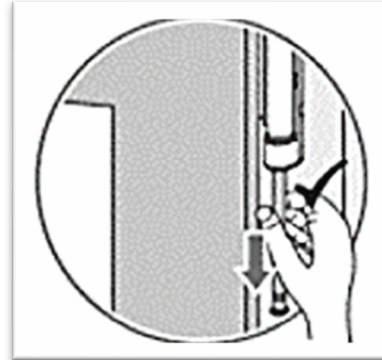

Step 2: Using the construction handle, turn the handle to the turn position and swing the sash open to approximately 45 degrees, maintaining a firm grip with both hands.

While securely holding the sash, pull it out from the top hinge, ensuring you are prepared to support its full weight and balance. Then, lift the bottom corner hinge off the pin to fully remove the sash.

Removing the sash at a 45° angle simplifies reinstallation, as it properly aligns for reinserting the cammed bushing at the top hinge.

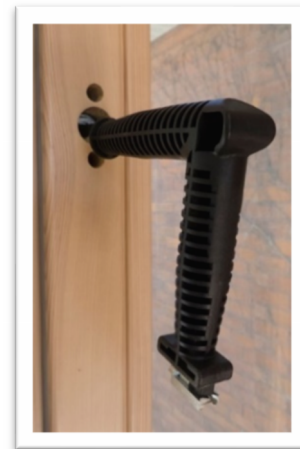

Reinstalling the Sash

To reinstall the sash, set the handle to the 'open' position, ensuring the upper stay is folded. Then follow these steps:

1. Set sash onto the pin of the lower hinge

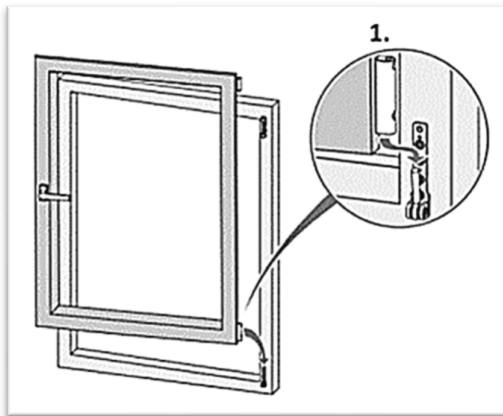

2. Press sash against frame and into upper hinge

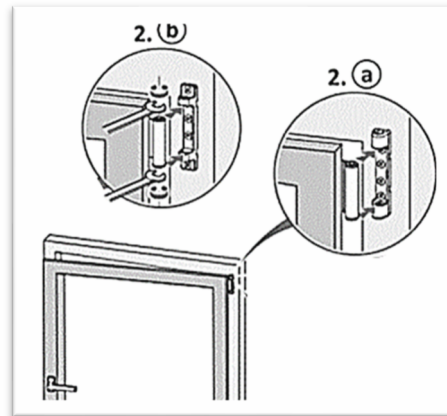

3. Insert the upper hinge pin, then set the handle to the 'closed.'

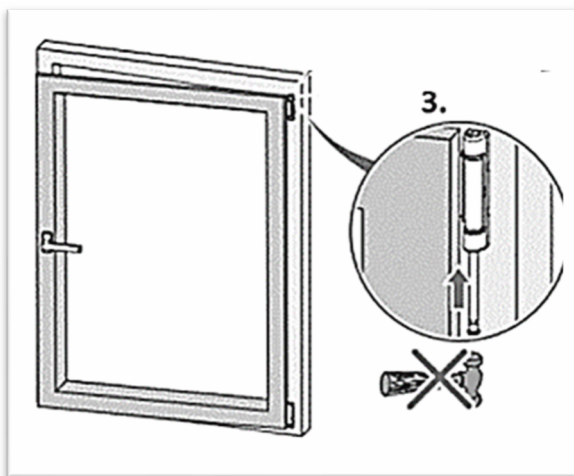

6.4 Window Handle Install

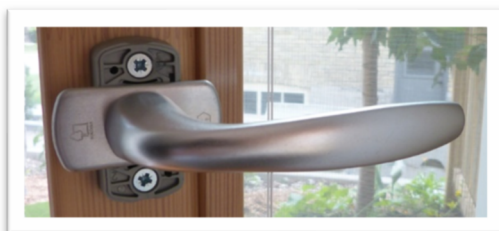

Align the handle position with the current operation of the sash. Rotate the cover plate to expose the screw holes.

Using a hand tool, fasten the provided screws, then rotate the cover plate back to conceal them.

6.5 Window Screen Install

Pre-install all the clips and screws (holes are predrilled), but do not tighten. Install the screens, rotate the clips, and fully tighten the screws. Screens may only be installed or removed from the interior of the building.

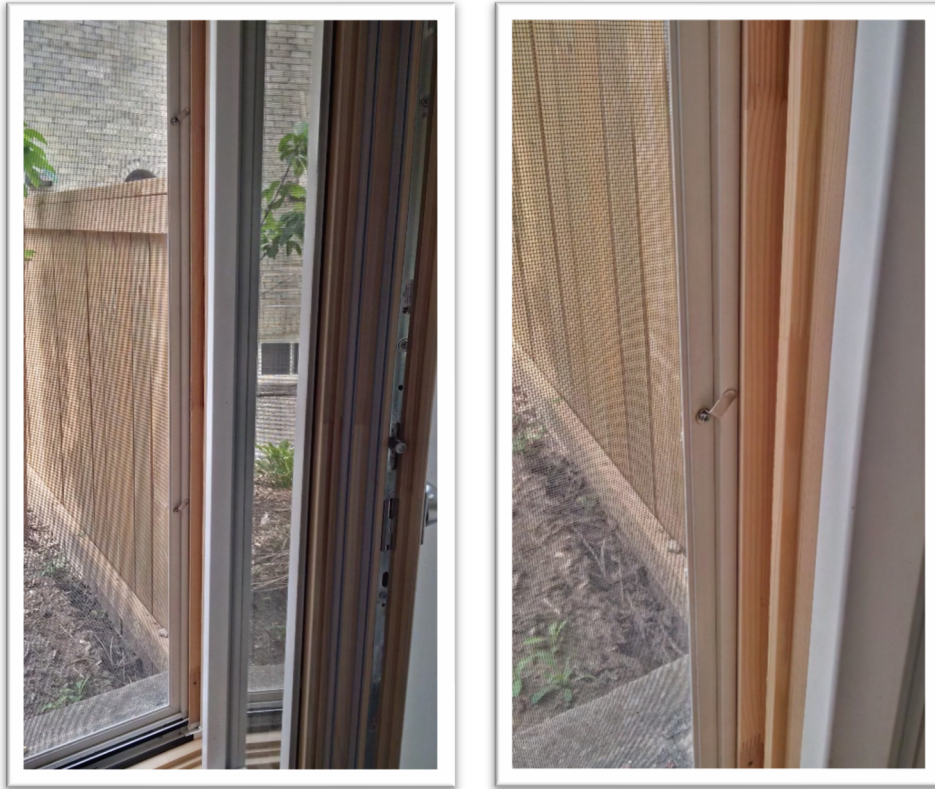

6.6 Common Elite/Summit Mullion Details

- Refer to section 4.6 for general mulling instructions. Always obtain specific mulling instructions from the VETTA project manager including any attached drawings of the specific condition. Non-standard mullied sets may require review by engineers to specify structural screws and reinforcement stiffening profiles.
 - [Elite E92 Details Pages \(27-32\)](#)
 - [Elite S68 Details Pages \(16\)](#)
 - [Summit C97 Details Page \(15\)](#)

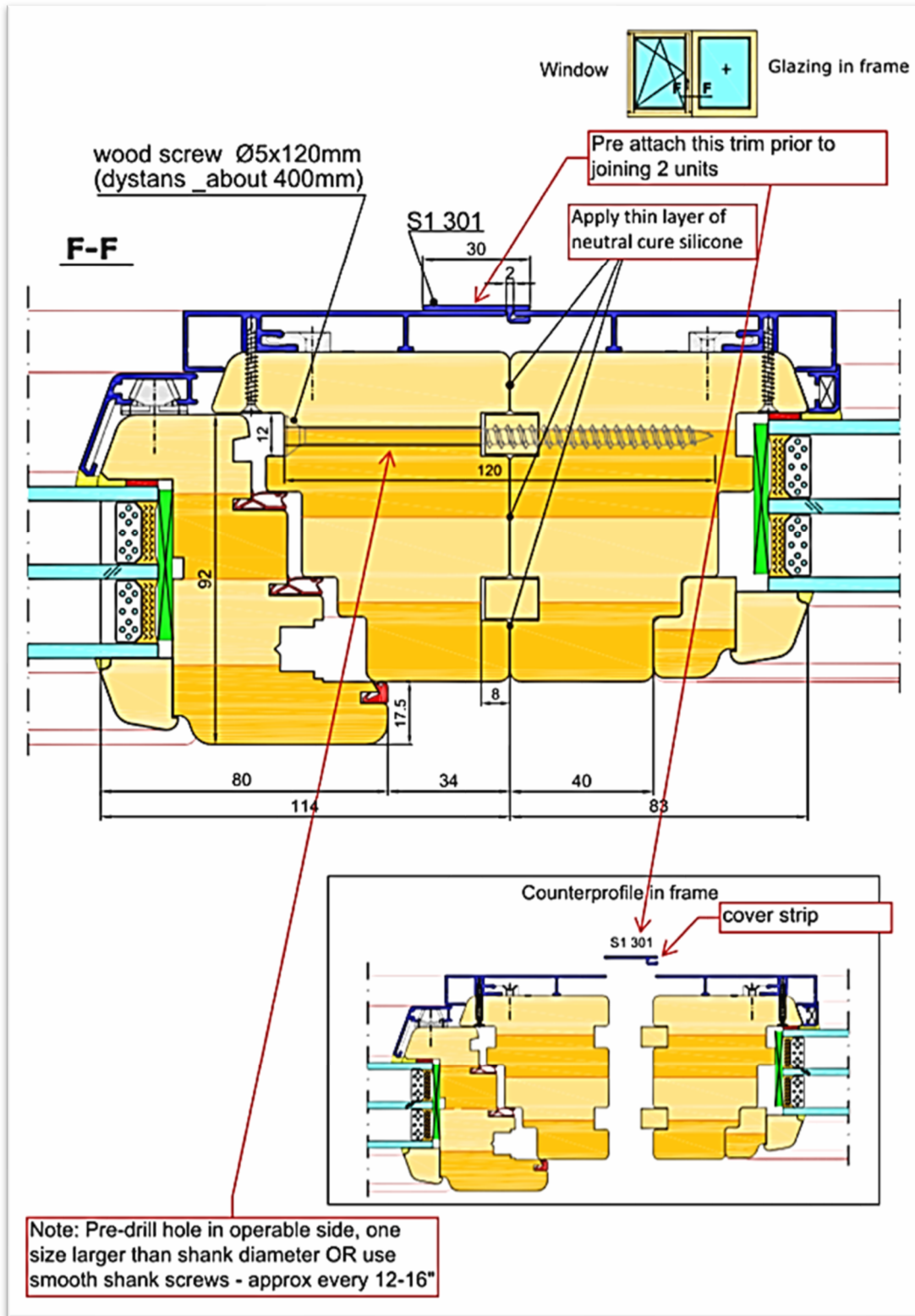

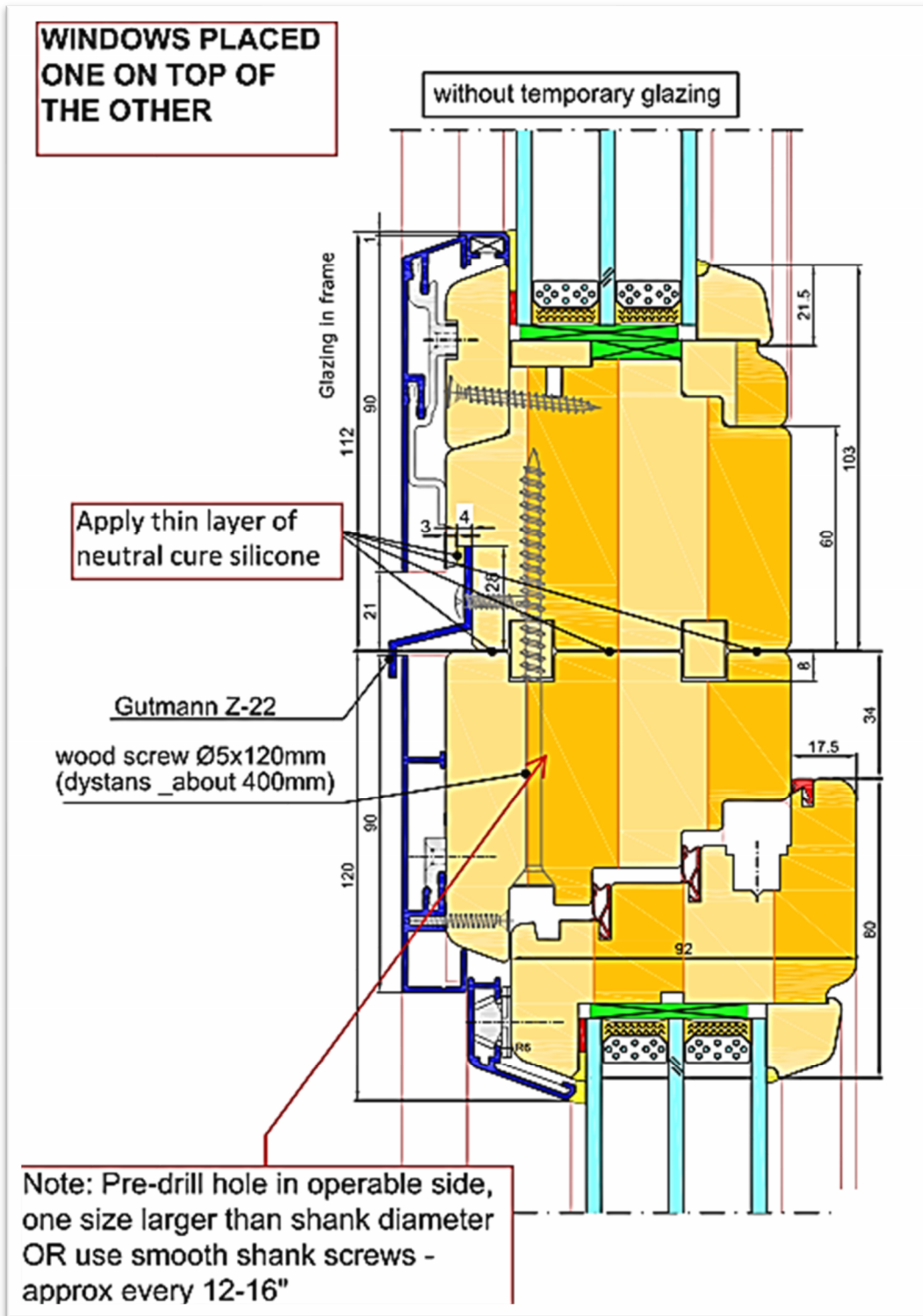

6.7 Elite/Summit Adjustments

IMPORTANT: Review Section 4.6 before reading the supplemental information below.

Tools required:

- Spanner/Allen key (11mm bolt and 4mm Allen) provided with your order



Legend

(A) Stay and top hinge

Regulates angle of sash

(B) Locking cams

Regulates pressure on frame and adjusts ease of handle operation

(C) Tilt sash hinge

(D) Corner hinge – rebate corner hinge – bottom hinge
regulates height of sash

(E) Door snapper

not applicable for windows

(F) Sash lift (no adjustment)

(G) Run-up (no adjustment)

(H) Load transfer

For windows with hidden hinges to adjust height and load of sash

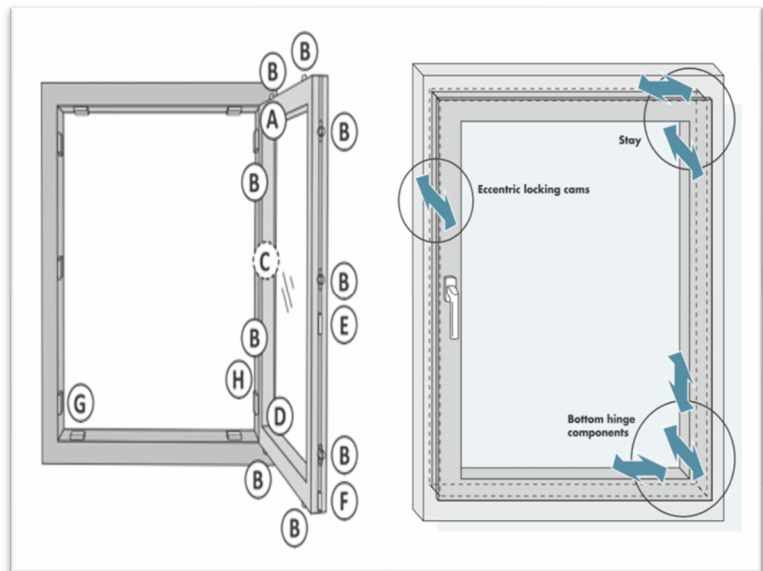

Standard Hinge on Stay – (A) on Previous Page Legend. Titan iP – Hinge side Titan/Si-line

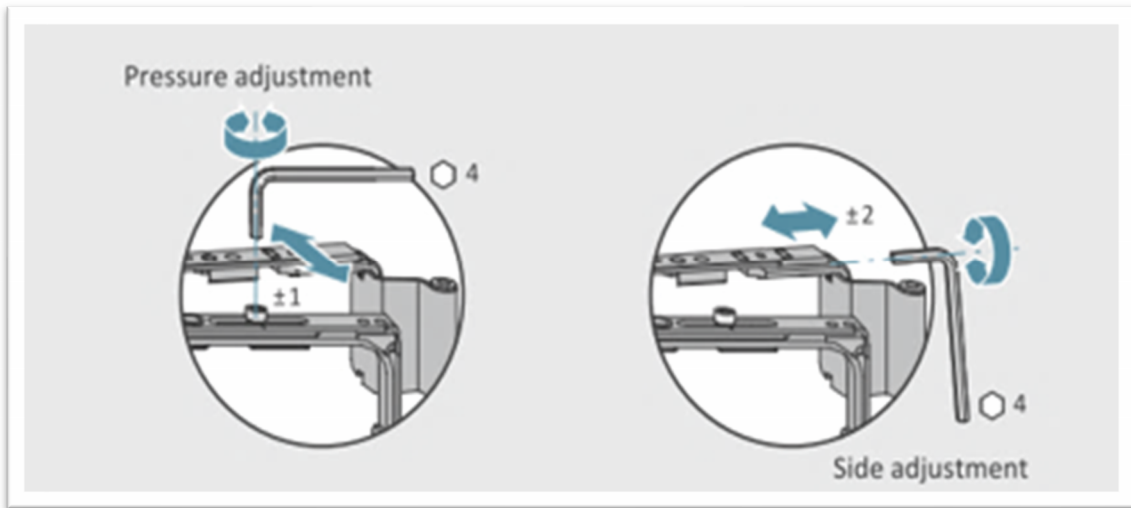

Locking Cam - (B) on Previous Page Legend.
Titan iP-AF comfort mushrooms

Bottom Frame Hinge - (D) on Previous Page Legend

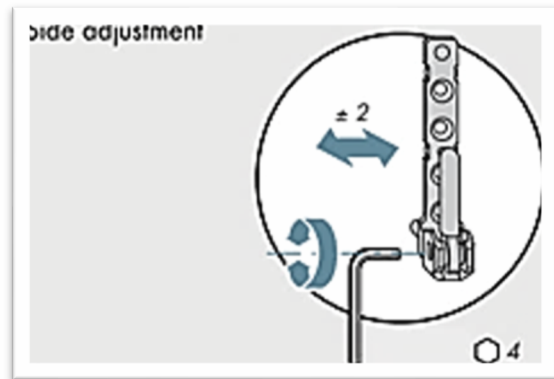
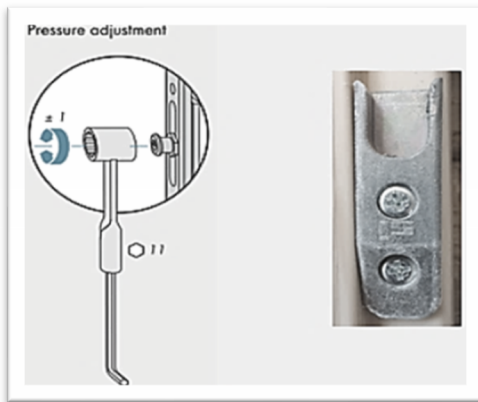

Bottom Sash Hinge - (D) on Previous Page Legend

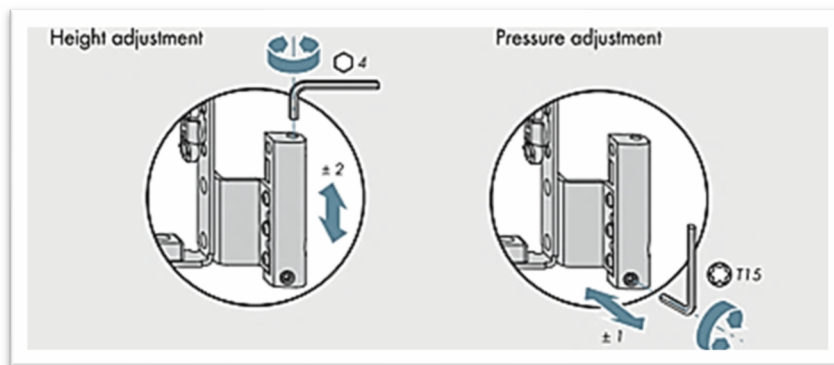

Stay – (A) on Previous Legend

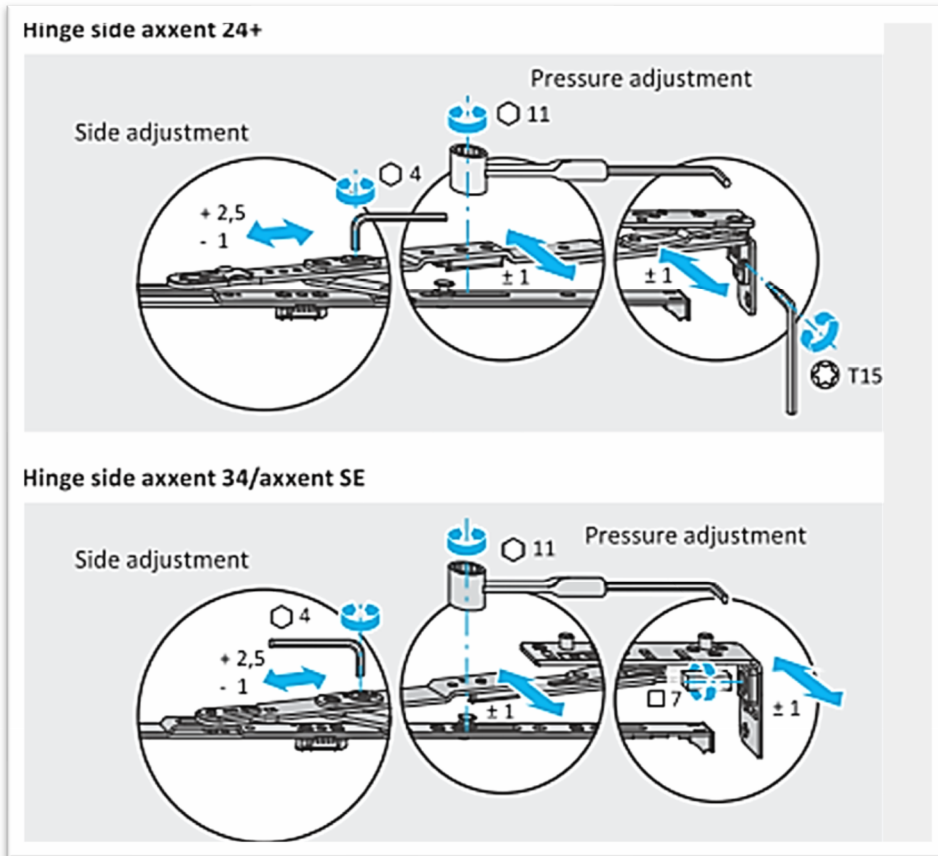

Stay/Top Hinge on Arched Window- (A) on Previous Legend

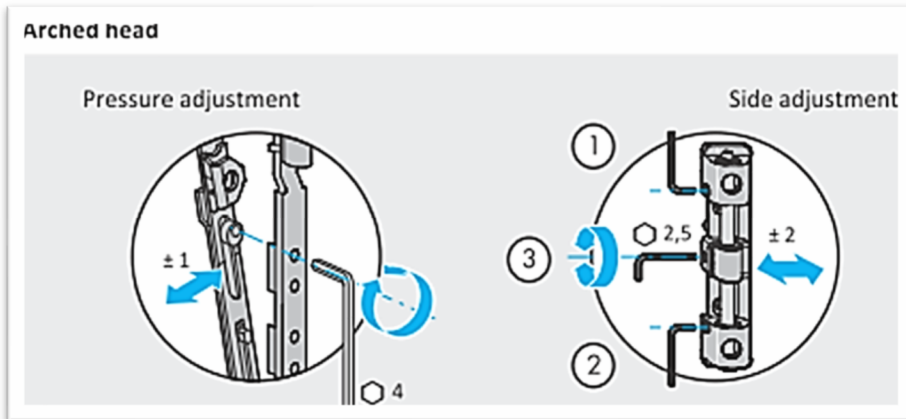

6.8 Lubrication

IMPORTANT: Review Section 4.7 before reading the supplemental information below.

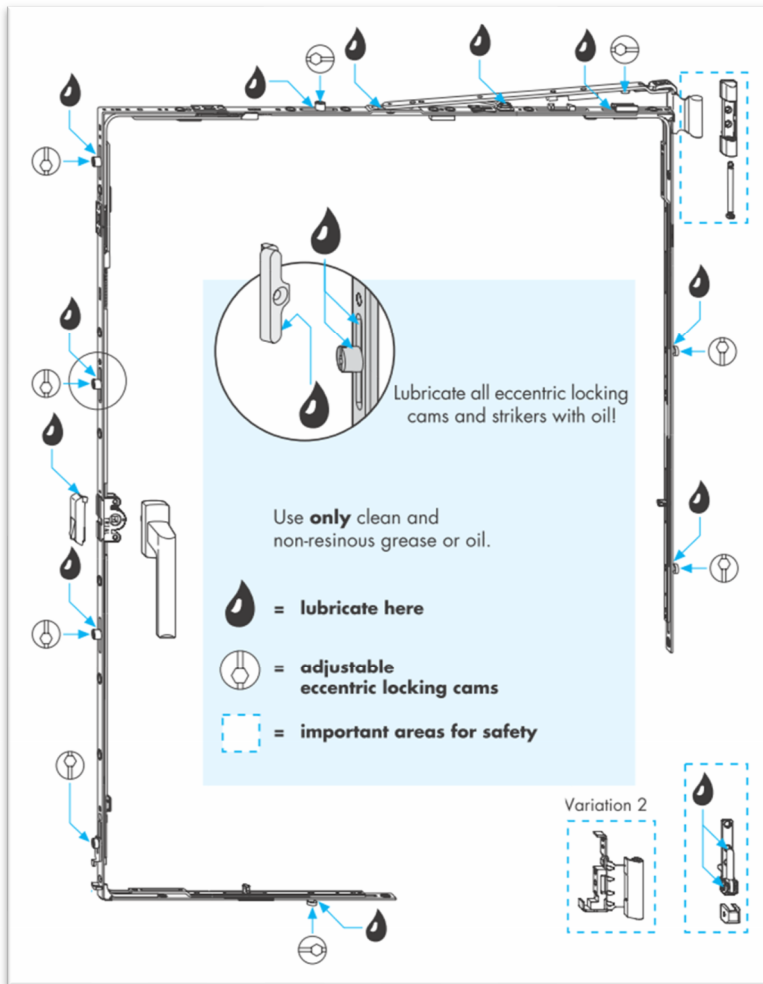

Stay - (A) on Previous Legend

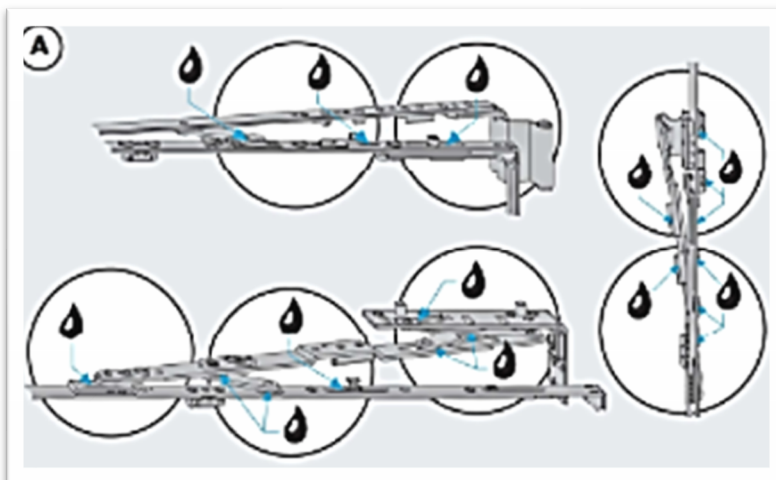

Catches - (C) on Previous Legend

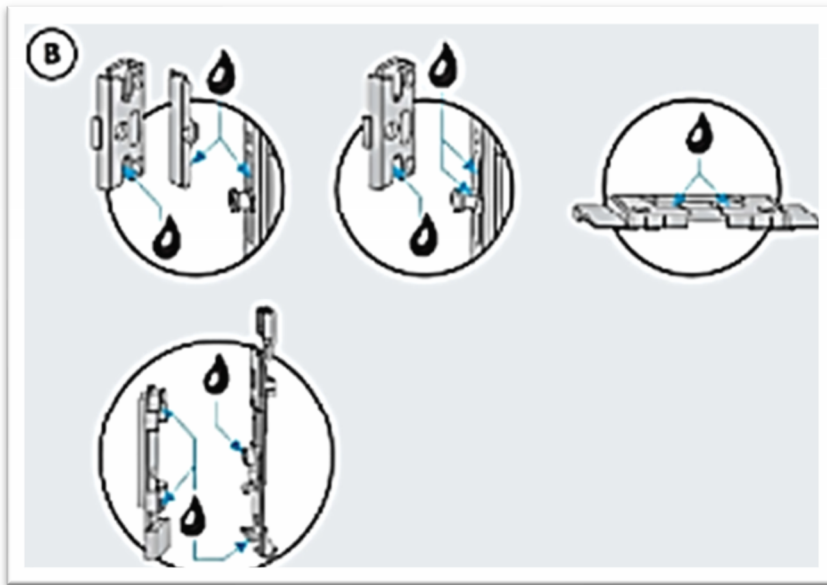

Hinges - (D) on Previous Legend

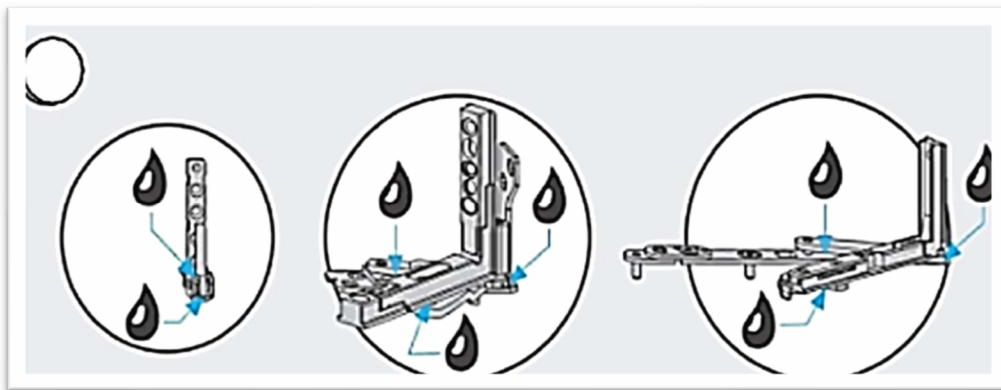



For more information watch these short tutorials on VETTA's YouTube channel.

[How It Works - ELITE E92 Window with Flying Mullion](#)

[How it Works - Winkhaus Limit Device for a Tilt Turn Window](#)

[How it Works - Handle Brake Stay for ELITE Tilt Turn Window](#)

[How To -Access Screws on a Hoppe Tilt & Turn Window Handle](#)

[How To - Install a Fly Screen](#)

[How To - Install a Glazing Unit on a Tilt Turn ELITE Window](#)

[How To - Prep the Rough Opening and Install a Tilt & Turn Window](#)

[How To - make a side and height adjustment on a Tilt & Turn Window](#)

[How To - Make pressure adjustments on a Tilt & Turn Window](#)

[How To – Repair a Disengaged Tilt/Turn Window](#)

[How To – Disengage Tilt-Only Windows](#)

7 Supplemental: Outward Opening Window (OPTIMA)

7.1 How To Operate

IMPORTANT: Review Chapter 1 before reading the additional supplementary information below.

This window opens outwards with four configurations – side hung, side guide, top hung and top guide.

Side Hung & Side Guide

Side Vertical Handle

Closed (1)

Opens Side Turn Function (2)

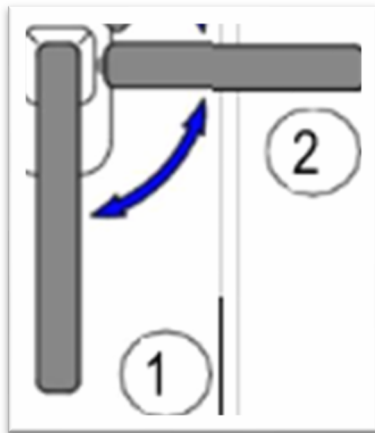

Top Hung & Top Guide

Bottom Horizontal Handle

Closed (1)

Opens Side Turn Function (2)

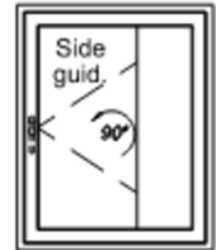
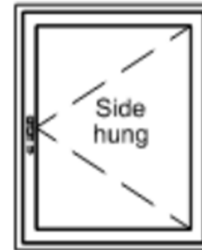
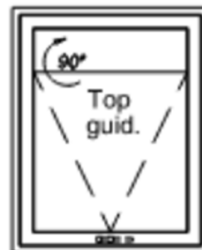
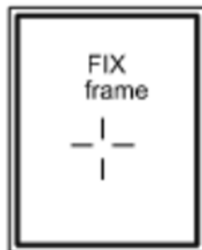
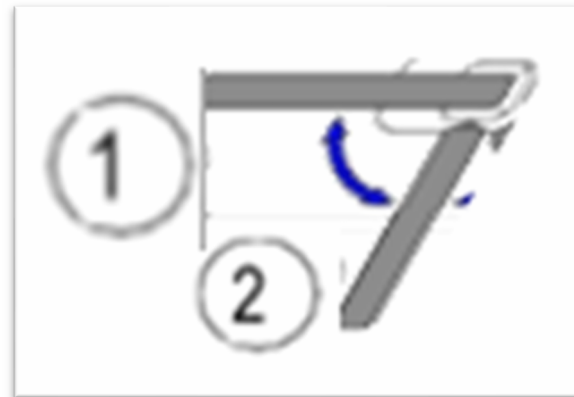

Side Hung



Side Guide



Top Hung



Top Guide



Top Guide Operation



The optional safety restrictor can limit the opening of the Top Guide Window. To open the window with the restrictor in place, move the sash 20mm to the rear, as shown on the left below. Push the restrictor arm in the direction of the arrow on the right to fully open the window. Once the window is closed, the restrictor automatically re-engages.

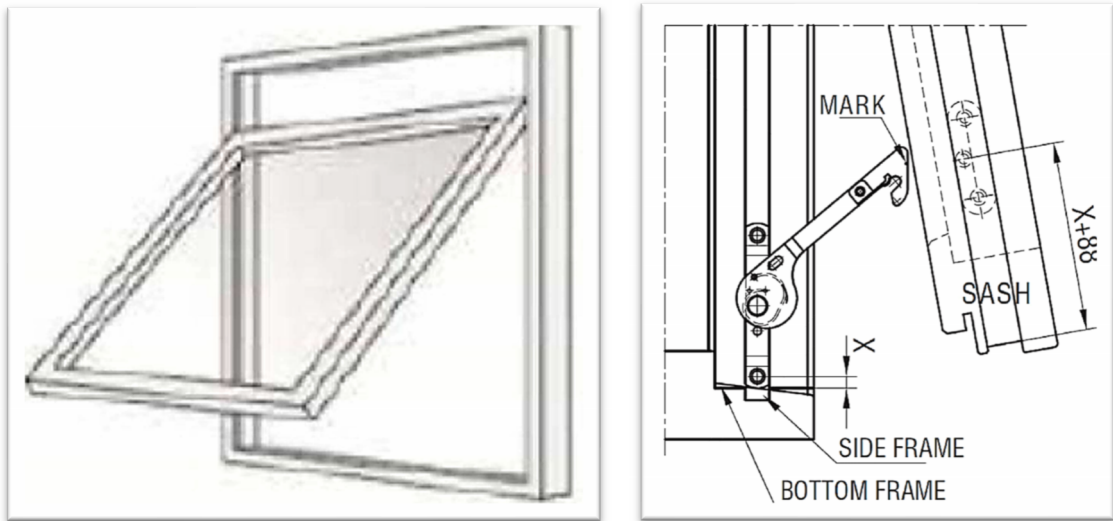

7.2 Design Considerations

IMPORTANT: Review Chapter 2 before reading the additional supplemental information below.

Exterior Sill / Flashing

VETTA's prefabricated sill can be installed as shown in the detail below.

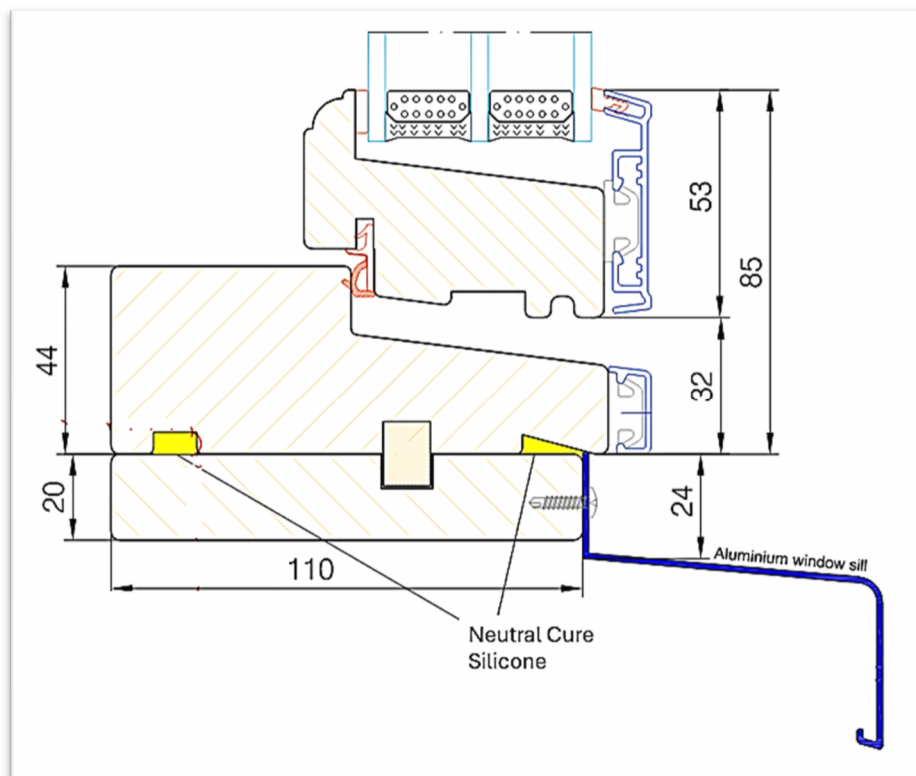

A 20mm frame extension is factory pre-installed. Apply silicone to the back of the aluminum sill before fastening it to the window frame.

7.3 Fixing Points

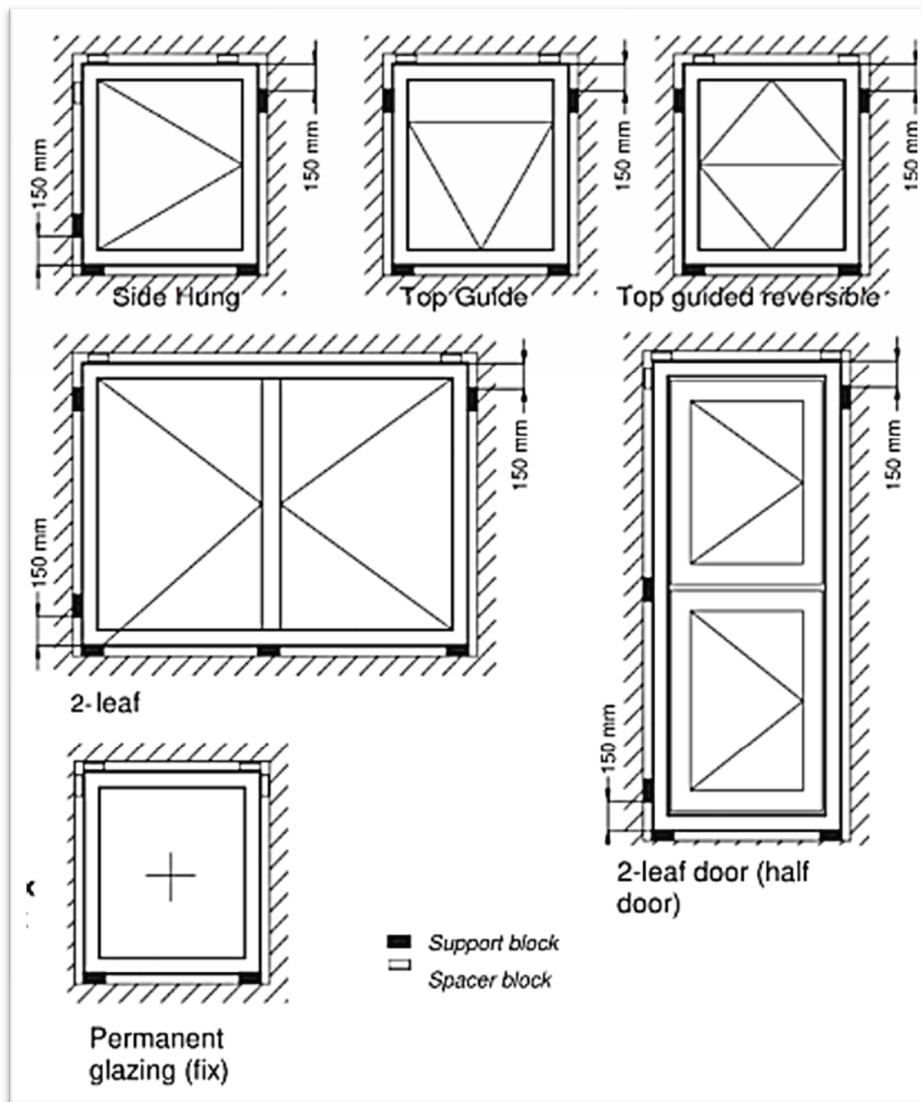

7.4 Operable Sash Removal & Install

IMPORTANT: Review Chapter 5 and Chapter 6 before reading the additional supplemental information below.

Side Hung Sash Removal

- Access the hinges by opening the sash.
- To remove the sash, use a 3mm Allen key to loosen the hinge set screws on the sash.
- Store the sash carefully in an upright position.

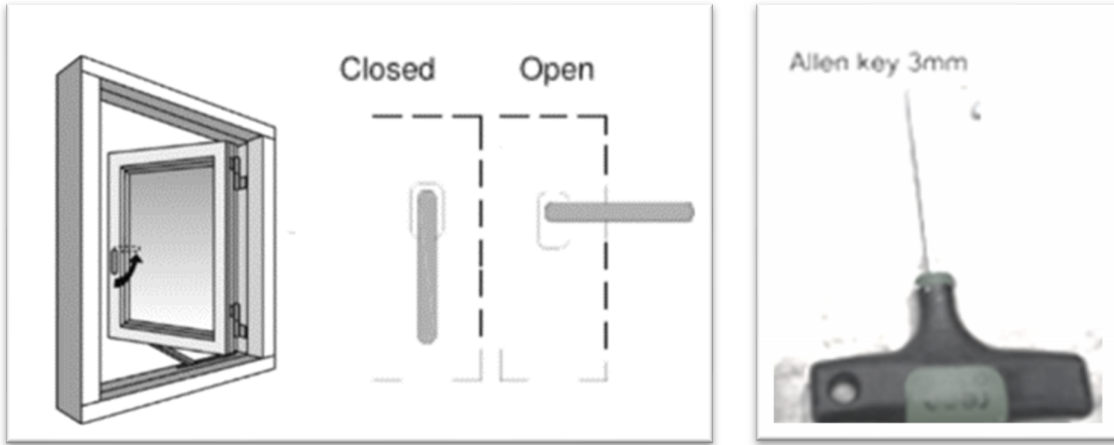

Top Hung Sash Removal

Access the hinges by opening the sash.

To remove the sash, use a Torx 20 key to loosen the bolts at location A in the diagram below. Once loosened, the sash can be pulled out.

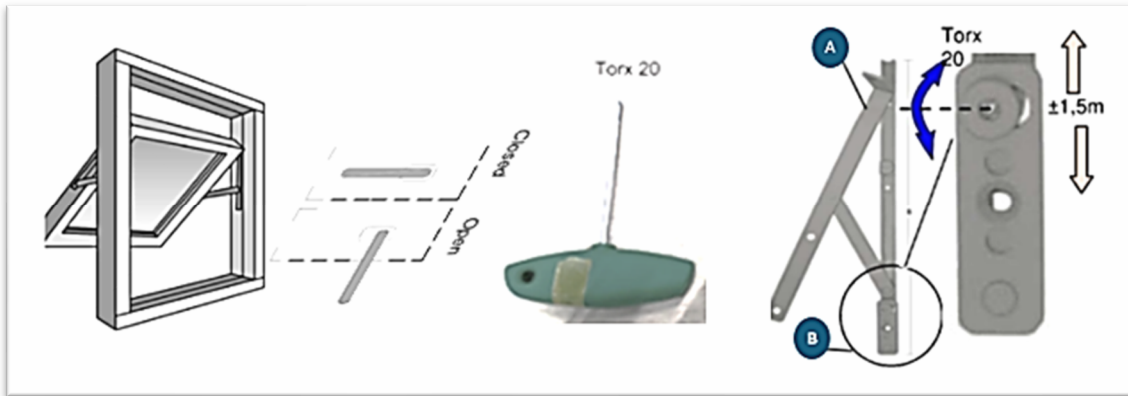

7.5 Common Optima Mullion Details

- IMPORTANT:** Refer to section 4.6 for general mulling instructions. Always obtain specific mulling instructions from the VETTA project manager including any attached drawings of the specific condition. Non-standard mullied sets may require review by engineers to specify structural screws and reinforcement stiffening profiles.

OPTIMA Windows to Each Other

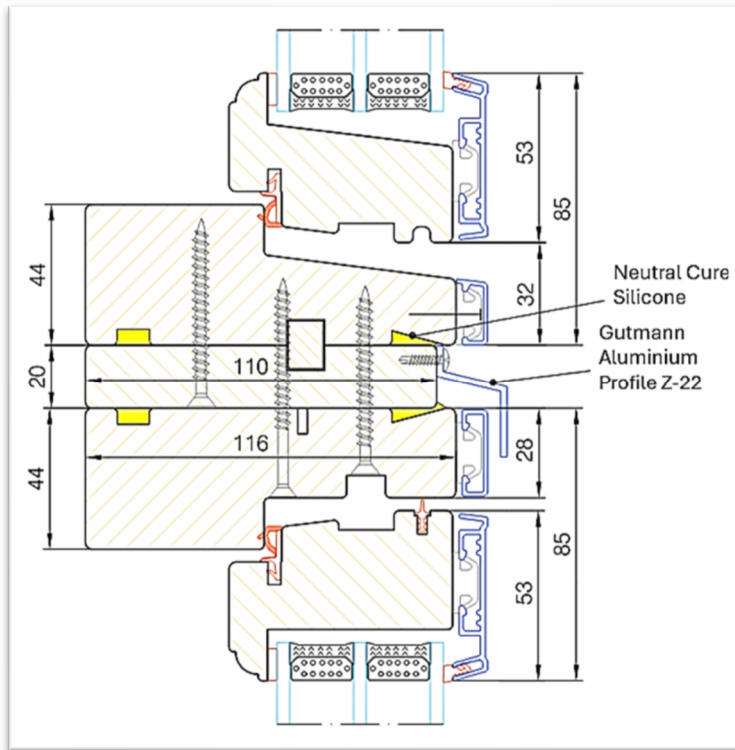

7.6 Optima Adjustments

IMPORTANT: Review Section 5.3 before reading the supplemental information below.

Tools required:

- Allen Key 6mm
- Allen Key 3mm
- Torx 20



For Top Hung and Guide windows, adjust the sash position by turning the bolt position by turning the bolt B with a Torx 20 key.

Before adjustment, loosen the bolt which fixes plate B.

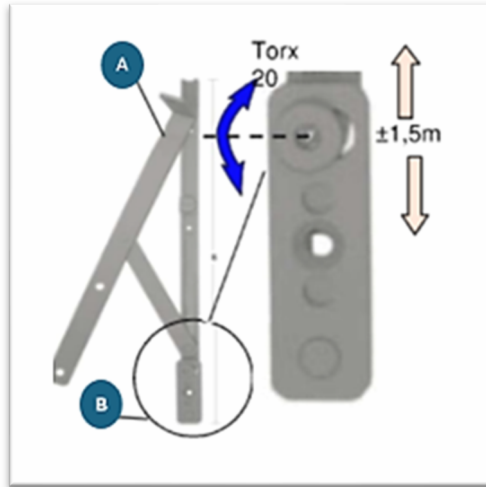

For Side Hung and Guide windows, adjust the gap between the sash and frame using the adjustment key to move the frame hinge.

7.7 Lubrication

IMPORTANT: Review Section 4.7, before reading the supplemental information below.

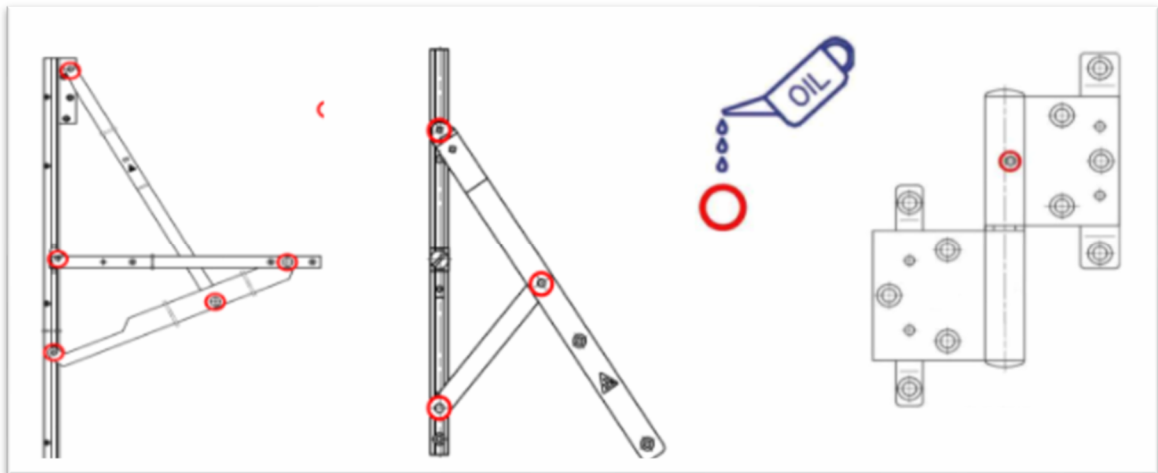

For more information watch these short tutorials on VETTA's YouTube channel.

[How It Works – OPTIMA Outward Opening Window](#)

8 Supplemental: Tilt & Slide Window or Juliette Balcony Door (ELITE E92)

8.1 How To Operate

IMPORTANT: Review Chapter 1 before reading the additional supplementary information below.

All Elite-series window frames can be adapted to the 'win/door-slide' style. The threshold is only available as a wood window threshold, meaning that when used as a door, it is limited to a Juliette balcony design with a safety railing. It retains the tilt function of a tilt-and-turn window and is operated and locked exclusively from an interior handle.

Tilting Open

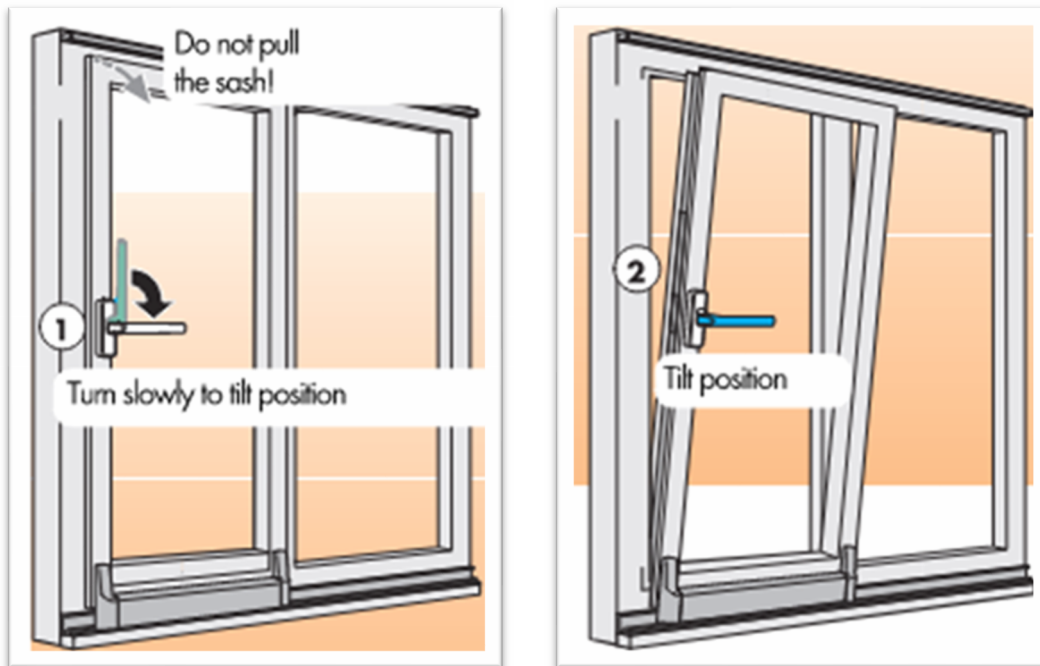

Tilting Close

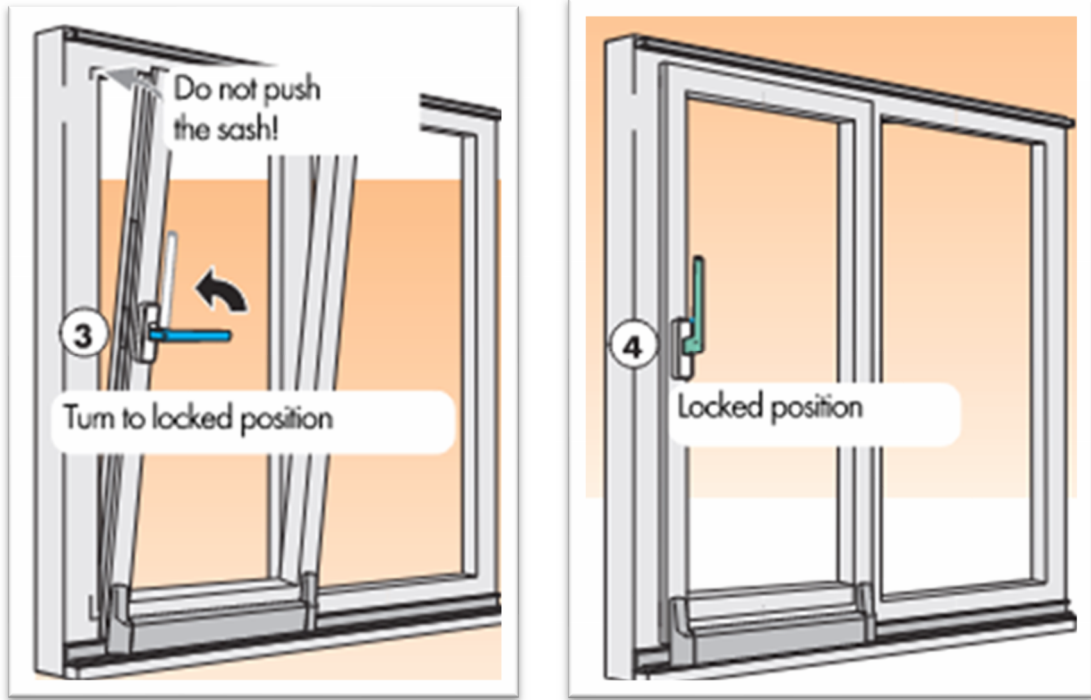

Sliding Open

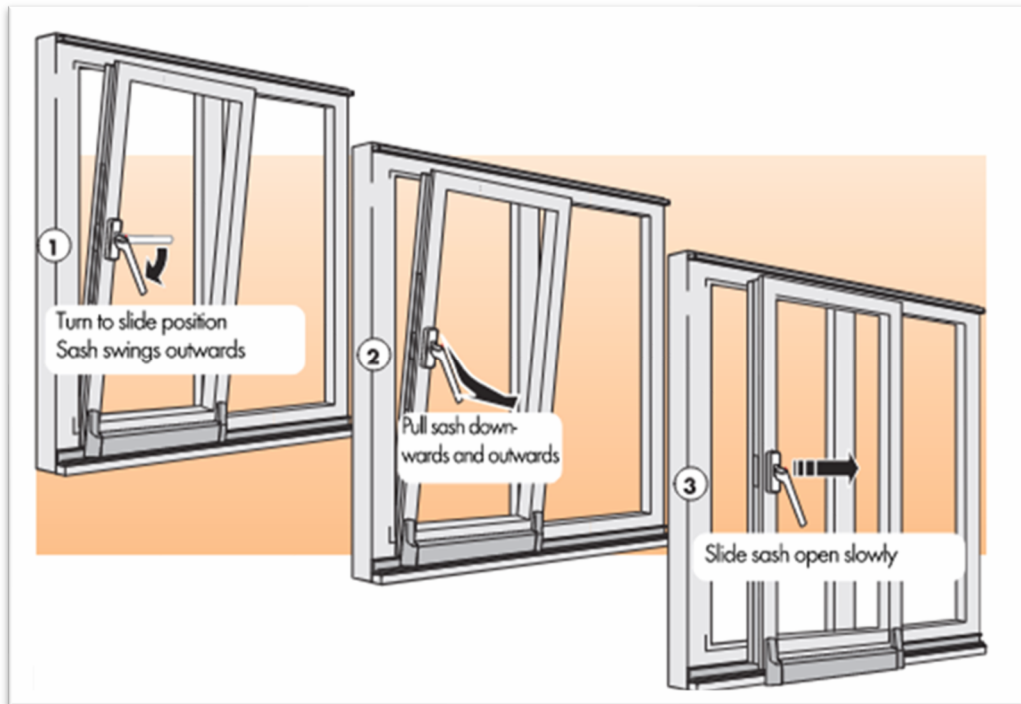

Sliding Closed

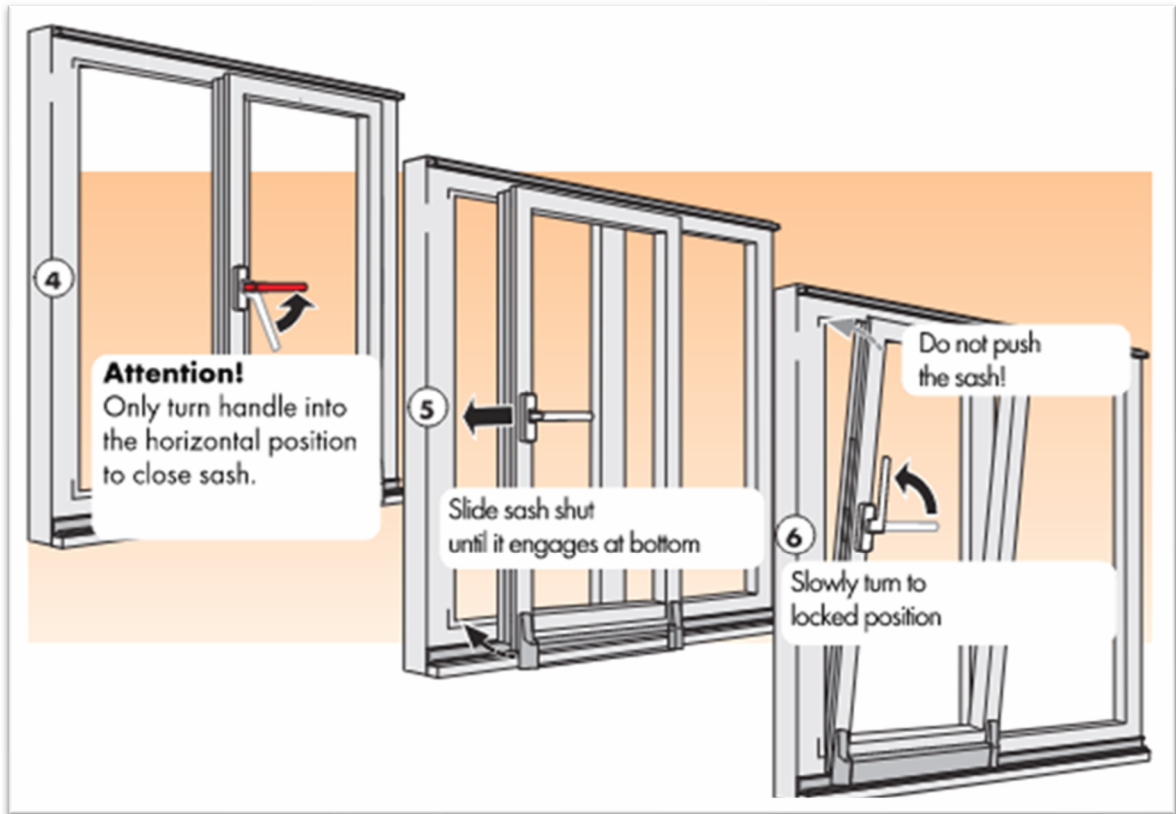

8.2 Design Considerations

IMPORTANT: Review Chapter 2 before reading the additional supplemental information below.

Exterior Sill / Flashing for Windows

ELITE windows follow the same engineered drainage principles as other VETTA products, directing water away from the structure through an exterior drainage path between the aluminum cladding and wood frame.

However, these models feature a dedicated drainage channel designed to manage water between the wood and aluminum components. Refer to the diagram below:

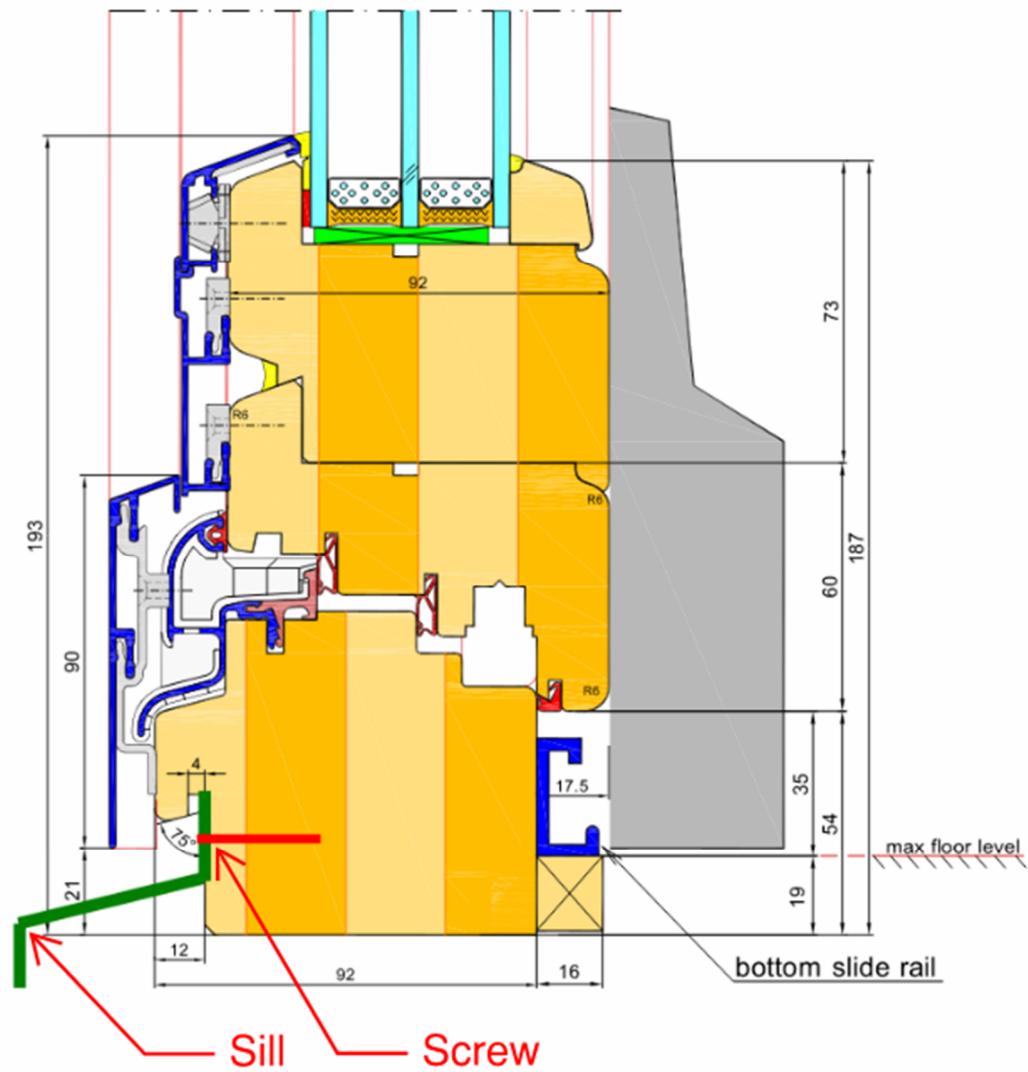

Water flows between the aluminum and wood. Blocking the bottom drainage will void the VETTA product warranty and may lead to water buildup at the subsill, increasing the risk of infiltration.

8.4 Fixing Points

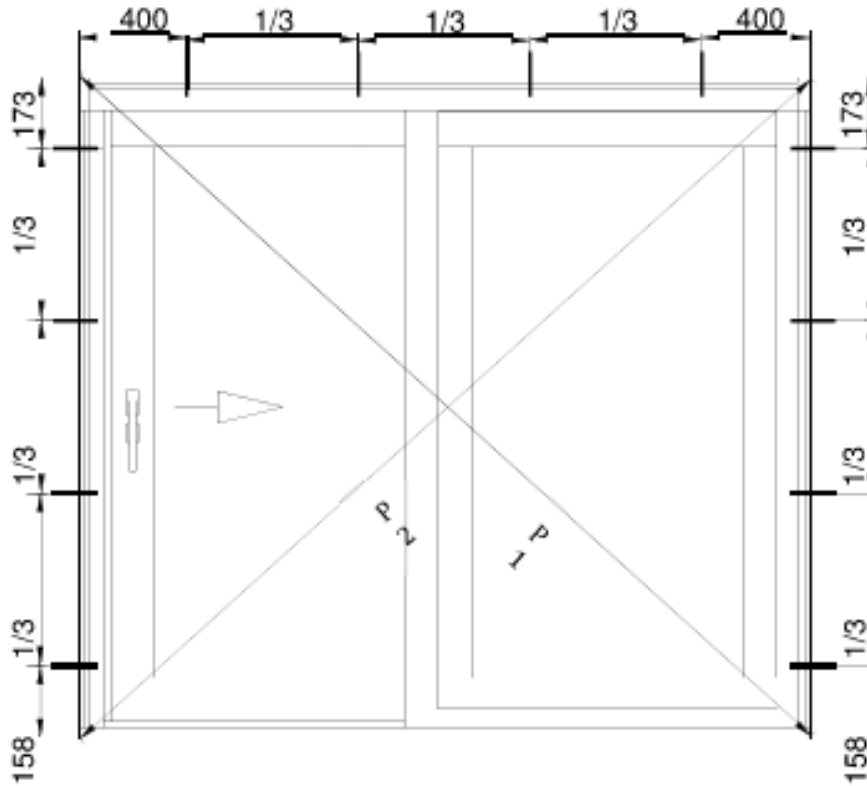

8.5 Operable Sash Removal & Install

IMPORTANT: Review Chapter 3 and Section 4.1 to 4.4 before reading the additional supplemental information below.

- A. To remove the sash, set the handle to tilt, then tilt the sash open.
- B. Use key to unlock the latches for the upper stays.
- C. Remove arms of upper stays from sockets, lift the sash.
- D. To install the sash, reverse this procedure.

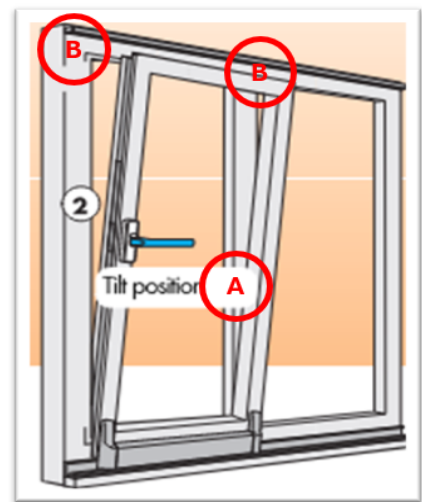
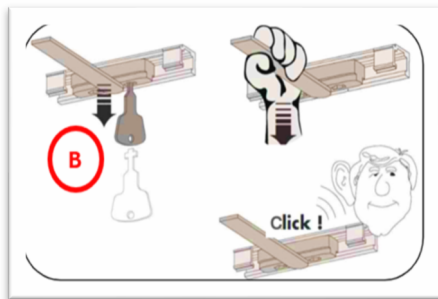

8.6 Tilt & Slide Adjustment

IMPORTANT: Review Section 4.6 before reading the supplemental information below.

Tools required:

Allen Key

- Spanner/Allen key (11 mm bolt and 4mm Allen) provided with your order.



Check the air latch resistance level (left side of diagram below) and direction setting (right side of diagram below). Adjust, if necessary, but do not exceed the maximum adjustment range.

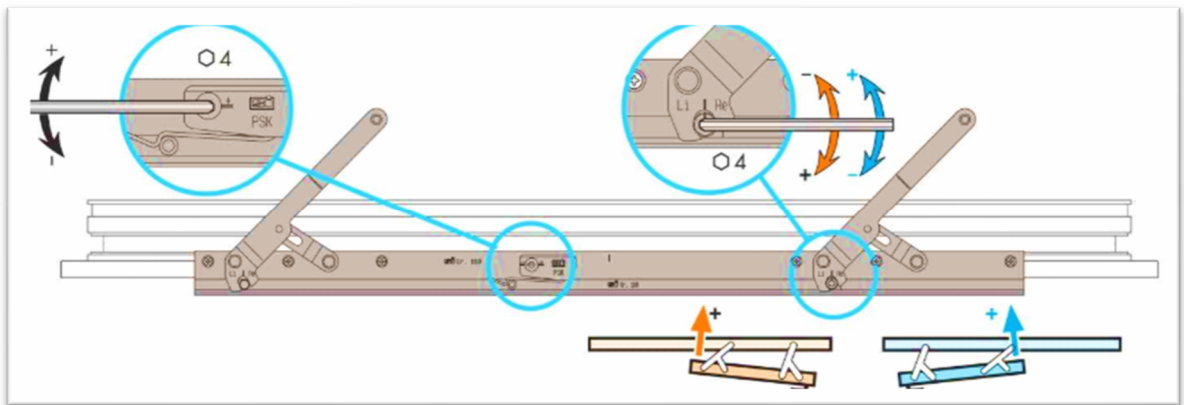

To set the height of the sash, adjust the bolt assembly where the sash is inserted. Loose the bolts, move the bolt assembly, and re-tighten (Torque 4-4, 5 Nm).

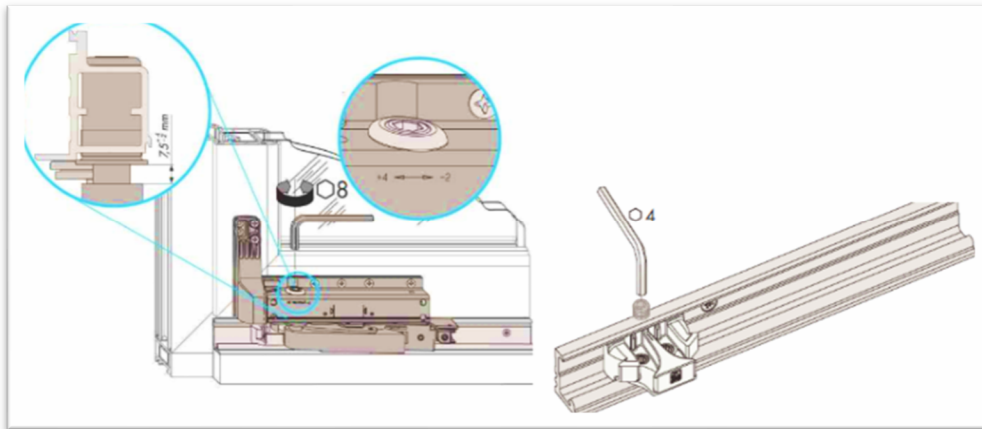

8.7 Lubrication

IMPORTANT: Review Section 4.7 before reading the supplemental information below.

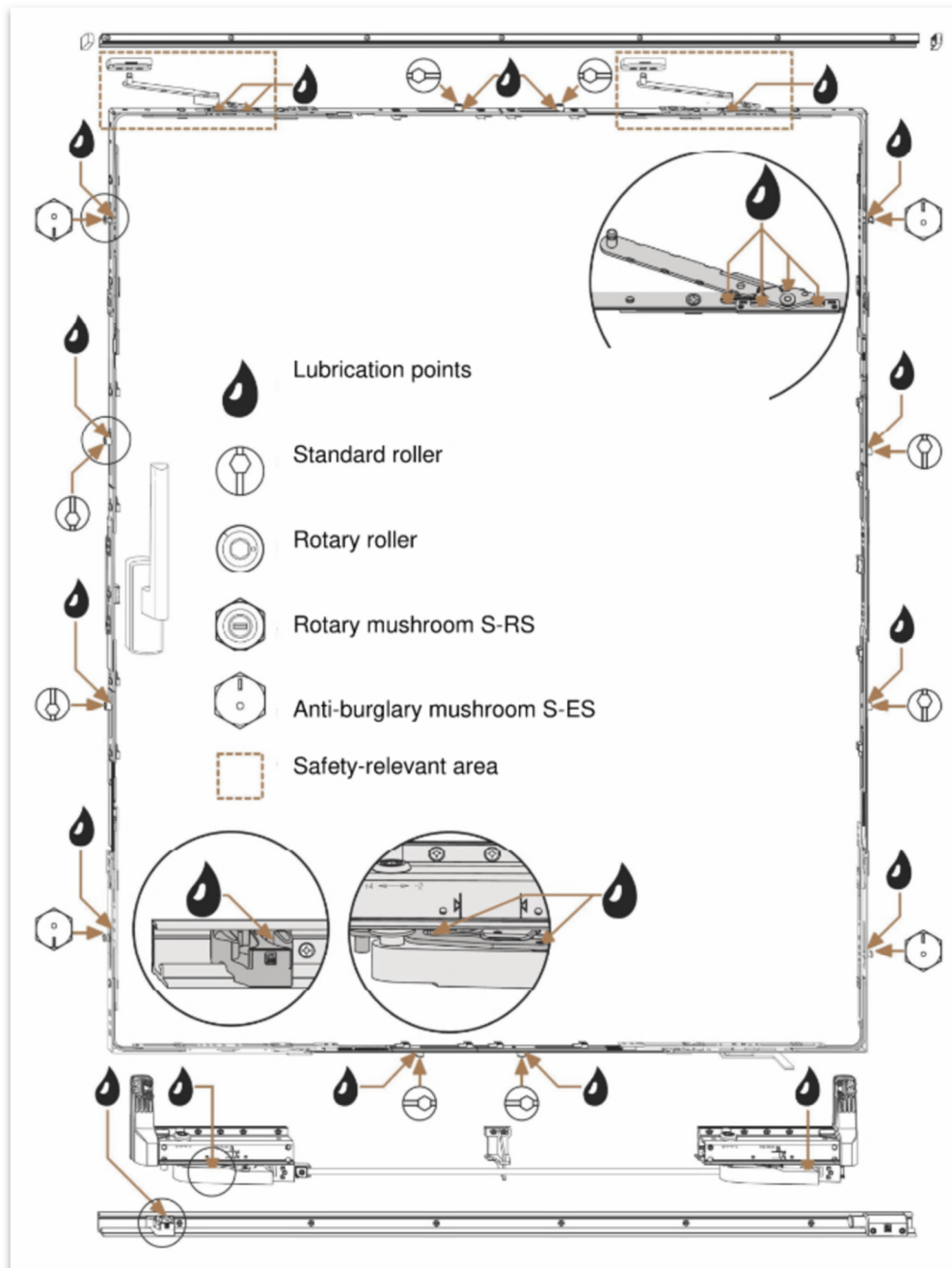

For more information watch this short video on VETTA's YouTube channel.

[How It Works - ELITE Tilt & Slide Juliette Balcony Door](#)

9 Supplemental: Lift & Slide with Interior Operable Sash (ELITE HS80)

9.1 How To Operate

IMPORTANT: Review Chapter 1 before reading the additional supplementary information below.

Turn the handle down to lift the interior sash off the threshold, then gently push to slide it open.

To hold the sash in any open position, turn the handle up to the closed position, which lowers the sash onto the threshold and secures it in place.

To close and lock, push the sash back onto the frame's upper and lower locking cams, then raise the handle to lower the sash onto the threshold. An exterior pull allows operation of the slide when open, with an optional exterior keyed lock available.

Lock assembly

1. Handle
2. Gear Box
3. Locking/Sealing Cam
4. Lock Strike

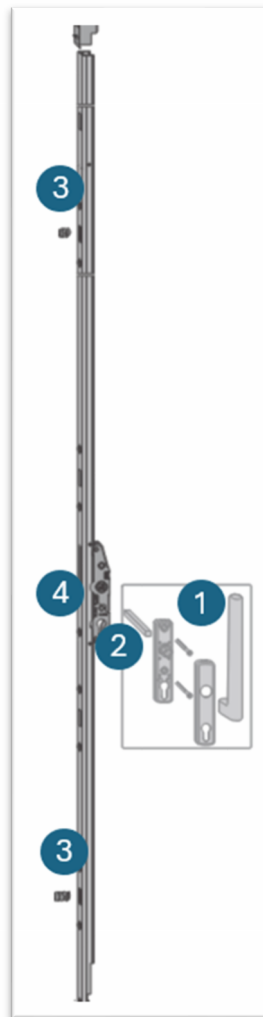
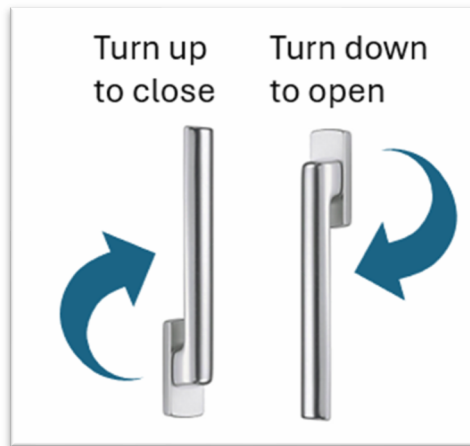

9.2 Design Considerations

Placement and Rough Opening

The Elite HS80 has a total frame depth of 206mm for the PATTERN A, C, and K models. The PATTERN E three-panel slider has a total frame depth of 314mm. Please confirm that the installation assemblies accommodate the increased frame depth.

- 1 – Inside vapour-tight film
- 2 – Mineral wool sealing
- 3 – Flashing
- 4 – Anti-wind film
- 5 – Screw
- 6 – Expansion tape sealing
- 7 – Insulation film
- 8 – Slide threshold (fiberglass)

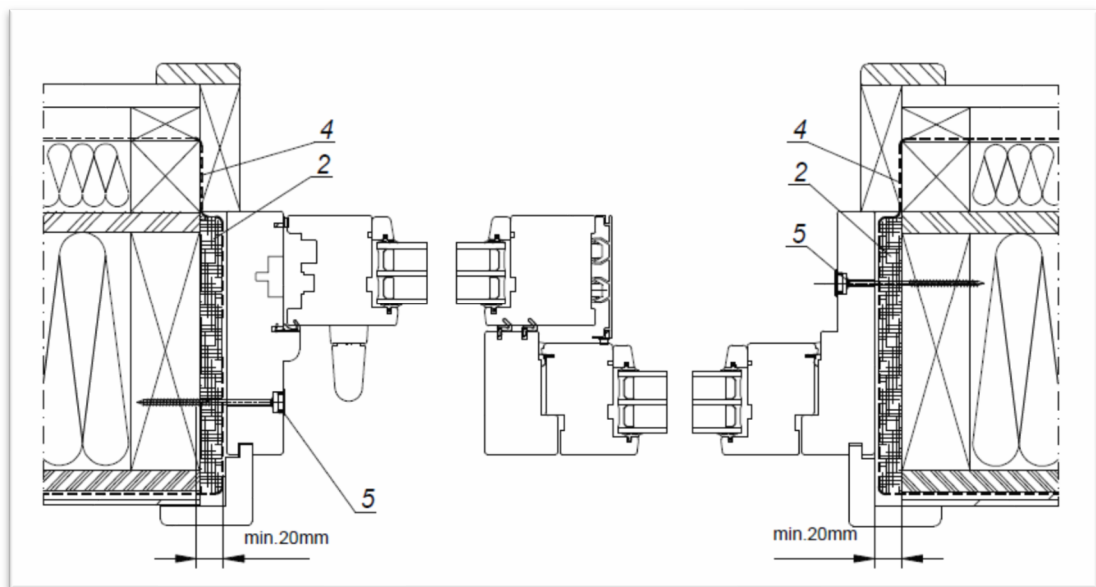
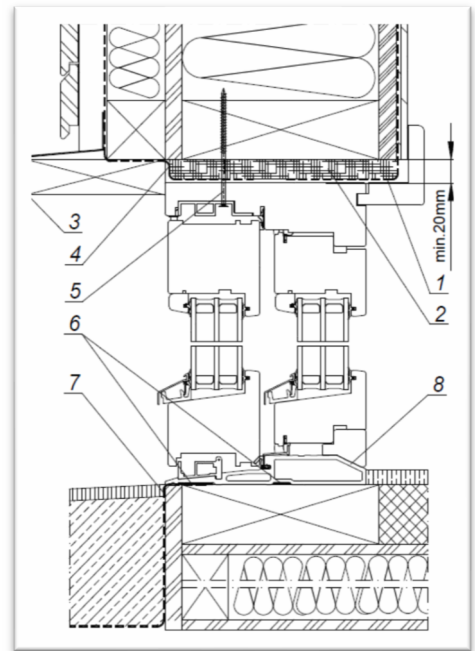

9.3 Fixing Points

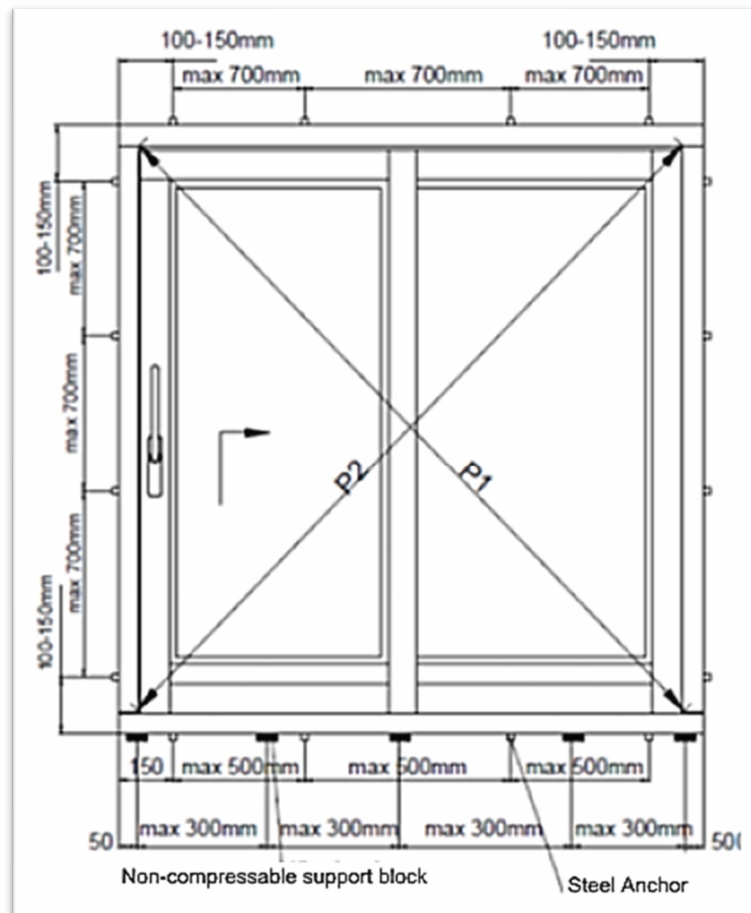
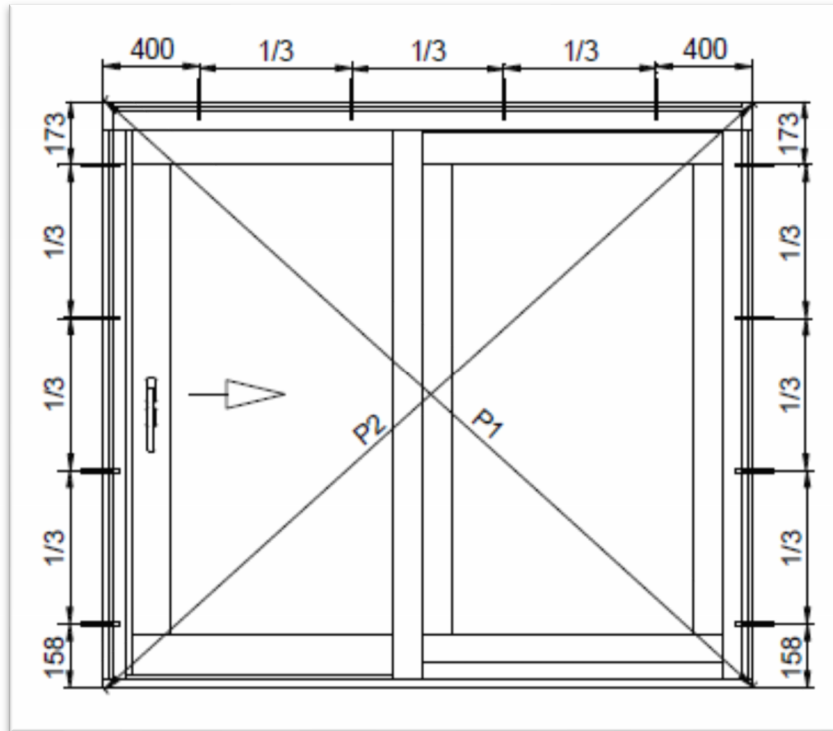

9.4 Operable Sash Removal & Install

IMPORTANT: Review Chapter 3 and Section 4.1 to 4.4 before reading the additional supplemental information below.

1. Set the handle to open, slide the sash.

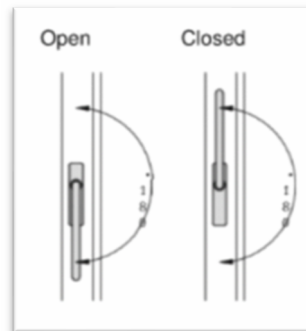

2. Holding the sash, undo bolts which fix A and B, then remove the sash from the frame.

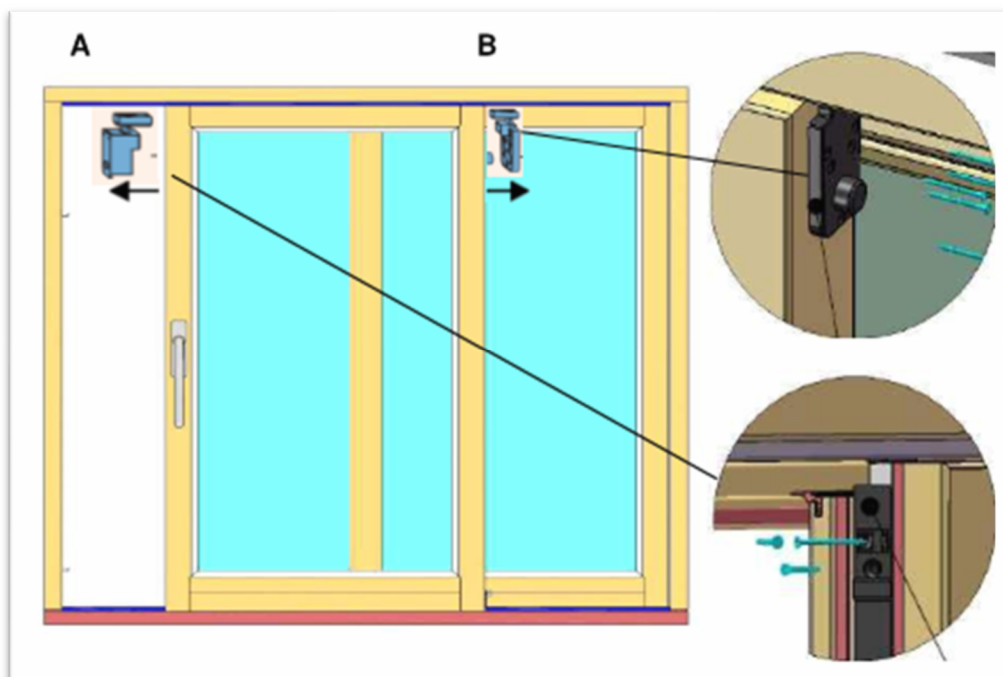

3. Tilt the sash inwards as shown on right, lifting the sash and taking it out of the frame.

To install the sash, reverse the procedure.

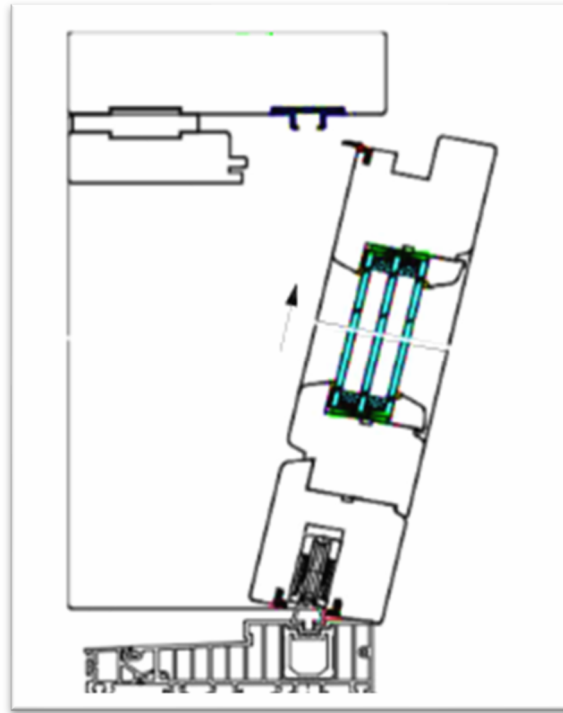

9.5 Handle Removal / Install

1. Insert the handle spindle into the rosette opening, ensuring it is positioned correctly as shown in the diagram below.
2. Slide the handle onto the spindle.
3. Use an Allen key to tighten the bolt securing the handle to the spindle.
4. Verify that the handle is properly fastened and operates smoothly.

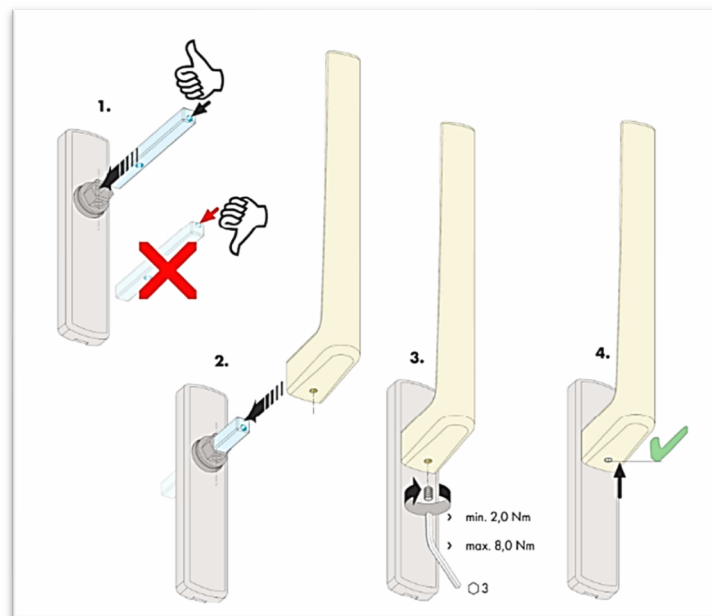

9.6 Combining Sets

Refer to section 4.6 for general mulling instructions. Always obtain specific mulling instructions from the VETTA project manager including any attached drawings of the specific condition. Non-standard mulled sets may require review by engineers to specify structural screws and reinforcement stiffening profiles.

The Elite HS80 are commonly mulled to the following:

- Elite Windows
- Optima Windows and Doors
- CAL Doors

Due to the size and complexity of these sets, as well as the involvement of trims and reinforcement profiles, it is essential that the builder or installer follows a factory-issued technical drawing specific to the installation conditions.

9.7 Plumb, Level & Square Assessment and Adjustment

IMPORTANT: Review Section 4.6 before reading the supplemental information below.

First, adjust the pressure of the sash against the frame by tightening or loosening the latching pins A of the frame.

Second, adjust the pressure of the sliding sash against the fixed sash by tightening the adjustment bolt B

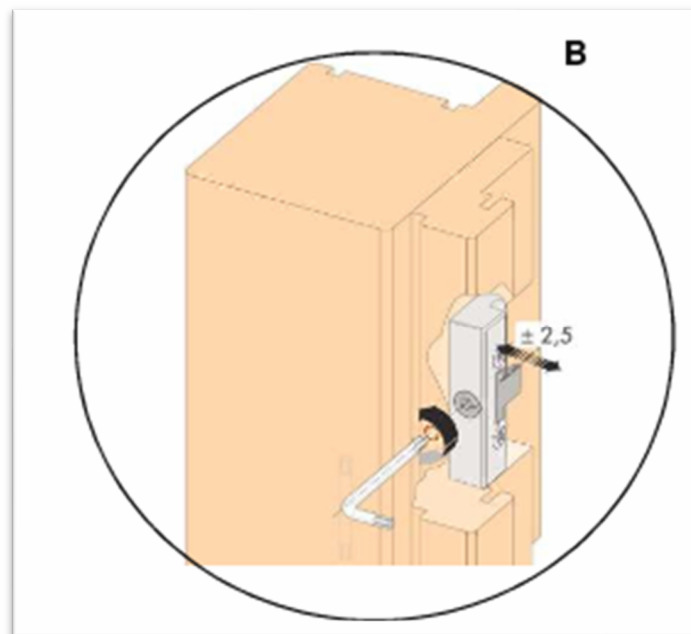

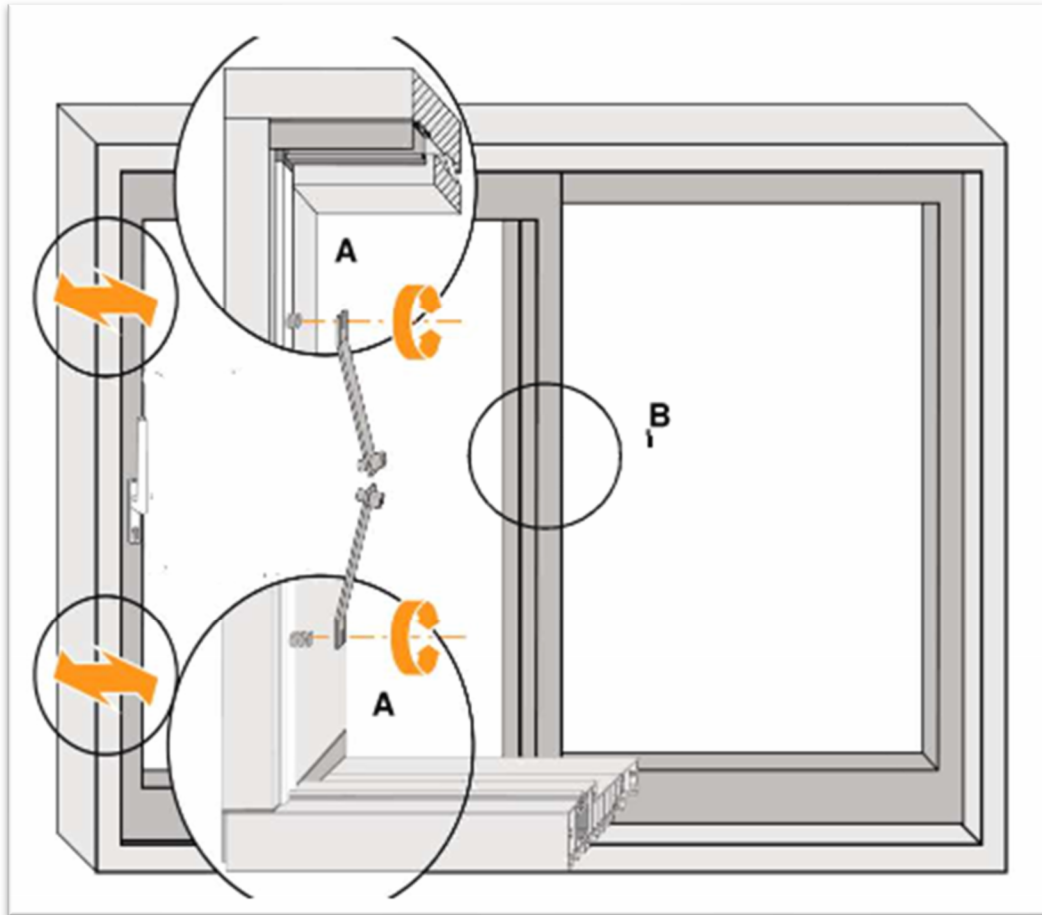

9.8 Lubrication

IMPORTANT: Review Section 4.7 before reading the supplemental information below.

Red: Use non-resinous grease or oil (e.g. 3 in 1 Oil). Green: Use silicone lubrication for rail track.



For more information watch this short video on VETTA's YouTube channel.

[How it Works – Night Vent on an ELITE HS80 Lift & Slide](#)

[How it Works – Elite Lift & Slide](#)

10 Supplemental: Slide with Exterior Operable Sash (OPTIMA Eco)

10.1 How To Operate

Raise the handle to release the exterior sash, allowing it to move slightly outward, then gently push to open.

To hold the slide in any open position, turn the handle down to the closed position, which pulls the sash back to the threshold and secures it in place.

To close and lock, push the sash back onto the frame's upper and lower locking cams, then turn the handle down to pull the sash in. An exterior pull allows operation of the slide when open, with an optional exterior keyed lock available.

Sash locking assembly

1. Handle
2. Gear Box
3. Locking/Sealing Cam
4. Locking Striker

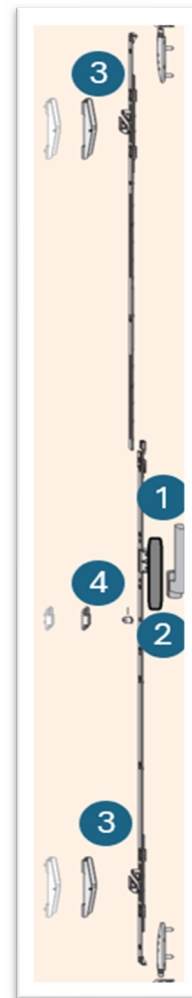
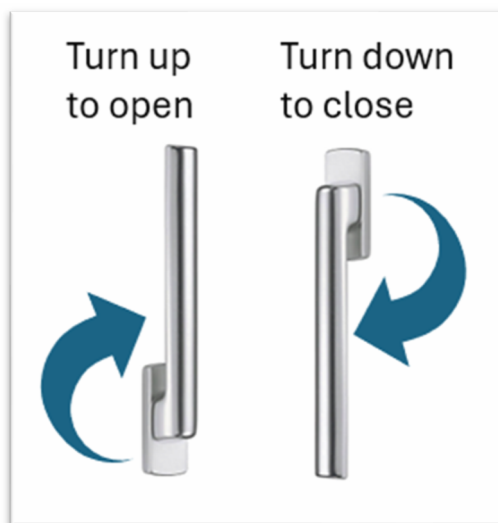

10.2 Design Considerations

Placement and Rough Opening

Illustrative installation details below:

- 1 – Inside vapour-tight film
- 2 – Mineral wool sealing
- 3 – Flashing
- 4 – Anti-wind film
- 5 – Screw
- 6 – Expansion tape sealing
- 7 – Insulation film
- 8 – Slide threshold (fiberglass)

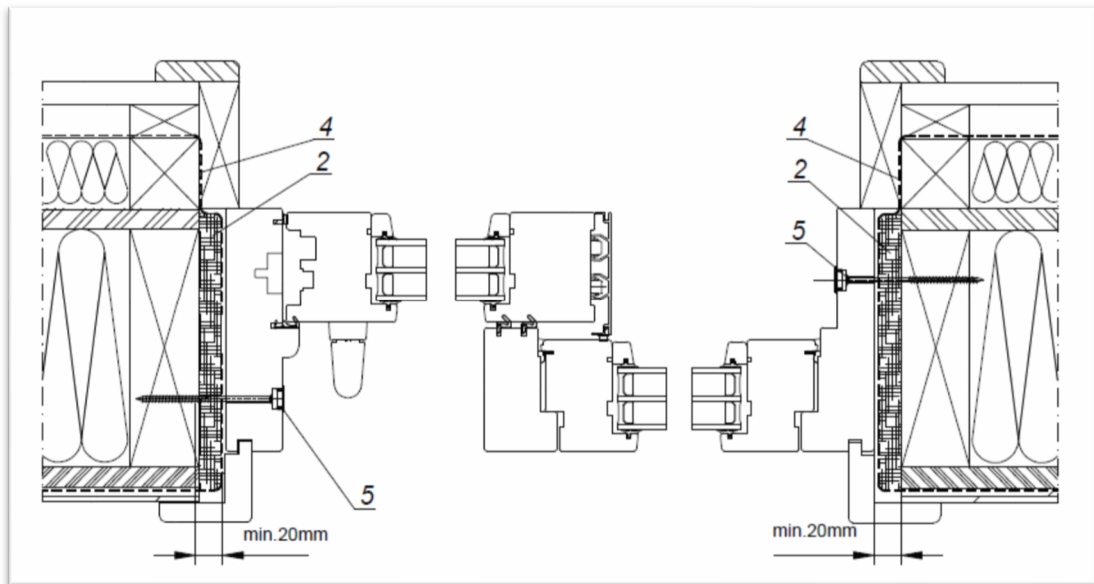
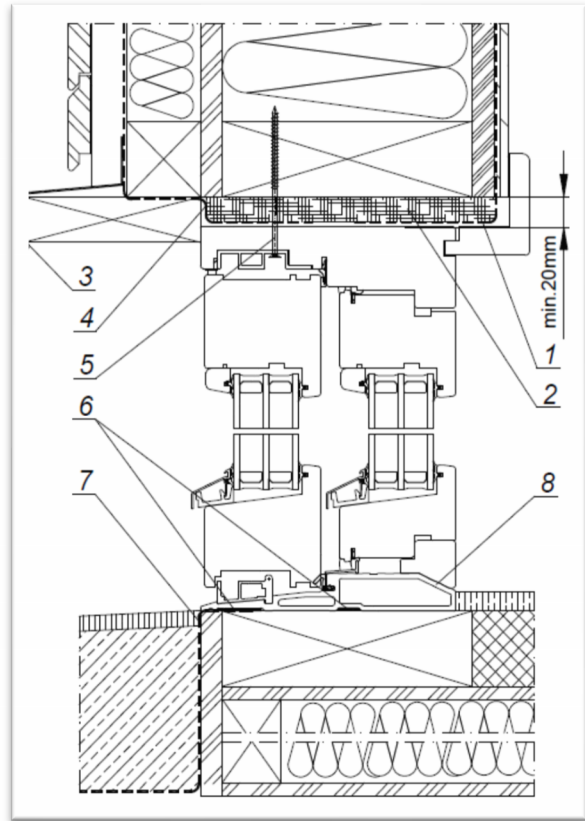

10.3 Fixing Points

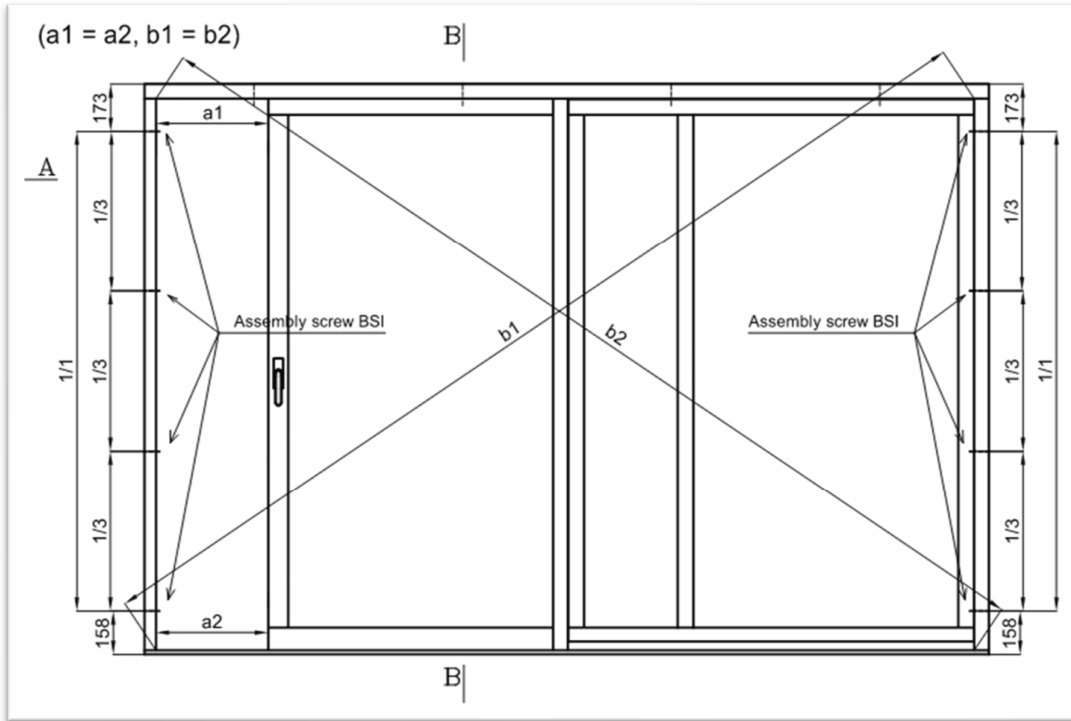

10.4 Operable Sash Removal & Install

On the exterior, set the handle to the open position.

From the exterior side of the operable panel, begin by removing the aluminum cladding on the inside vertical face of the panel (see reference pictures below).

The most effective method is to insert a wooden or plastic wedge between the aluminum cladding and the frame, then tap downward from top to bottom until the cladding separates from the clips.

Once fully loosened, carefully remove the cladding, avoiding excessive force to prevent damage.

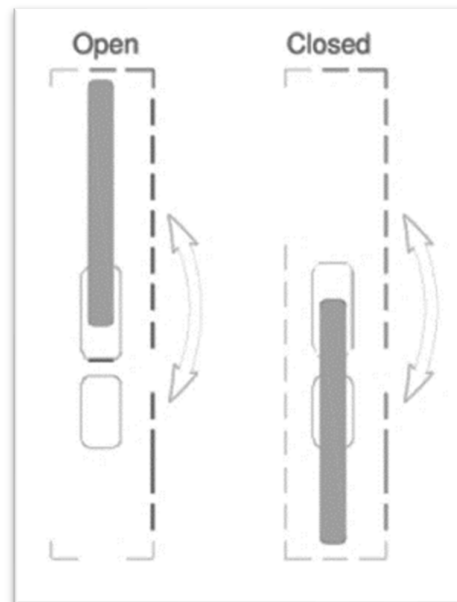



When the vertical cover is removed, the top and bottom rolling pins, which slide along the grooves in the track, become visible. They can also be seen from the interior when the sash is open (right image).



Carefully remove **only** the top rolling pin, tilt the sash out from the frame and lift out from the bottom slider track. (**CAUTION when the top rolling pin is removed, nothing is catching the panel at the top and can potentially tip over. Provide sufficient labor to ensure the panel is well balanced and supported.)

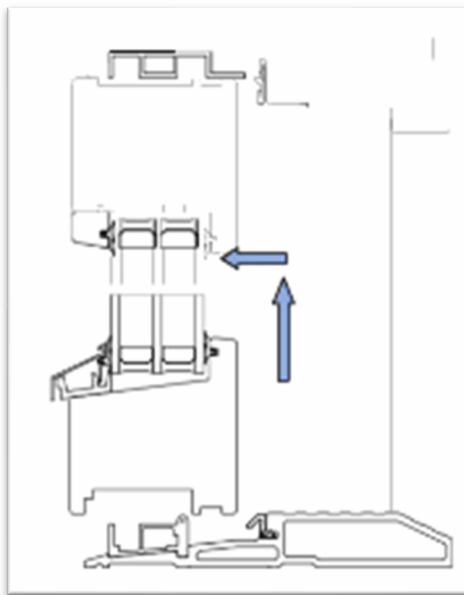

To install the sash back to the frame, proceed the same way in reverse order.

***Important: Adjust the wheels of the sliding rail in the correct position before placing the sash on the bottom slide rail

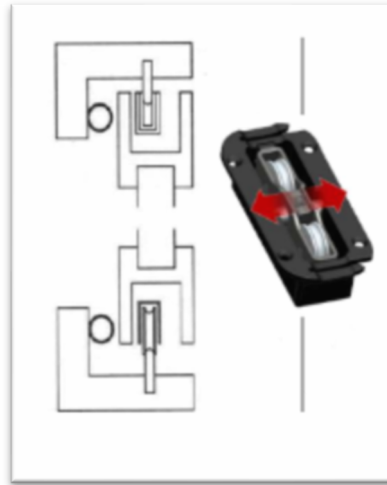

10.5 Combining Sets

Refer to section 4.6 for general mulling instructions. Always obtain specific mulling instructions from the VETTA project manager including any attached drawings of the specific condition. Non-standard mulled sets may require review by engineers to specify structural screws and reinforcement stiffening profiles.

Due to the size and complexity of these sets, as well as the involvement of trims and reinforcement profiles, it is essential that the builder or installer follows a factory-issued technical drawing specific to the installation conditions.

10.6 Plumb, Level & Square Assessment and Adjustment

IMPORTANT: Review Section 4.6 before reading the supplemental information below.

The upper and bottom roller pins can be adjusted to raise or lower the sash within t millimeters of installation tolerance. Ensure the adjustments do not exceed the limit, as over-adjusting may prevent the rollers from properly engaging with the track.

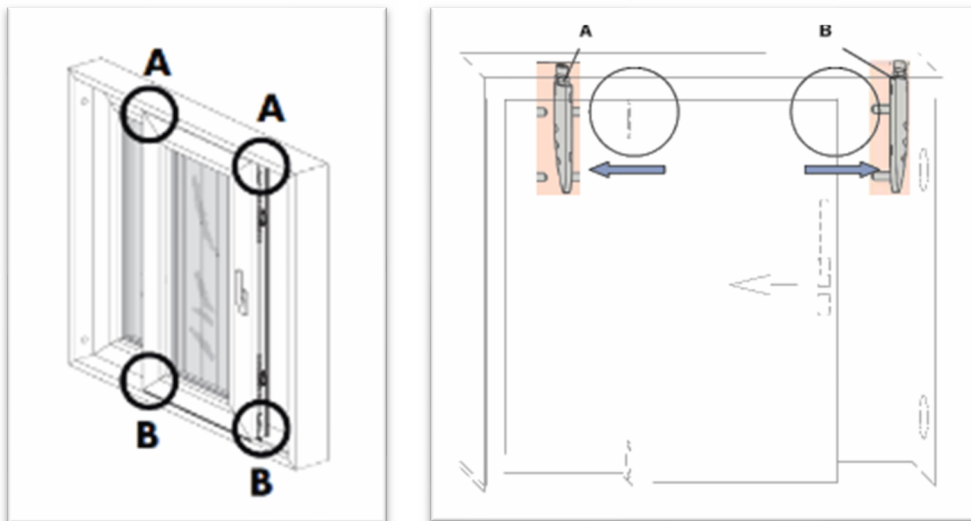

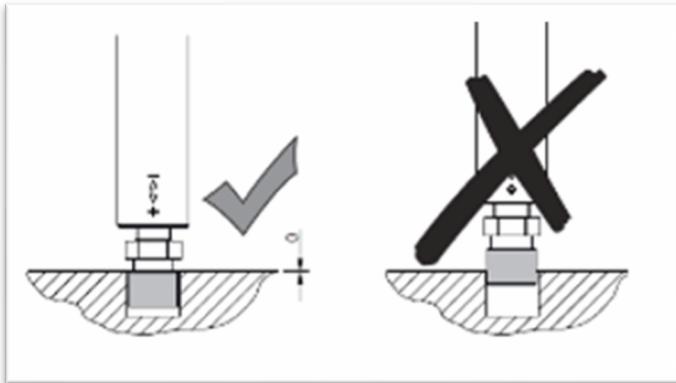
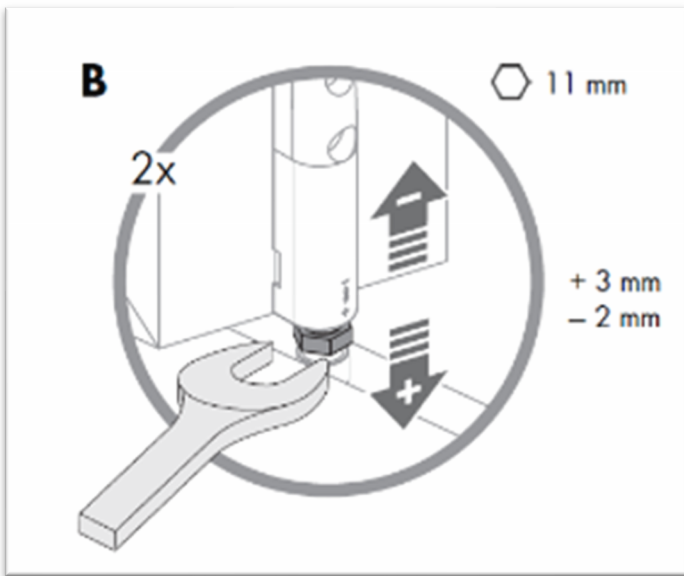
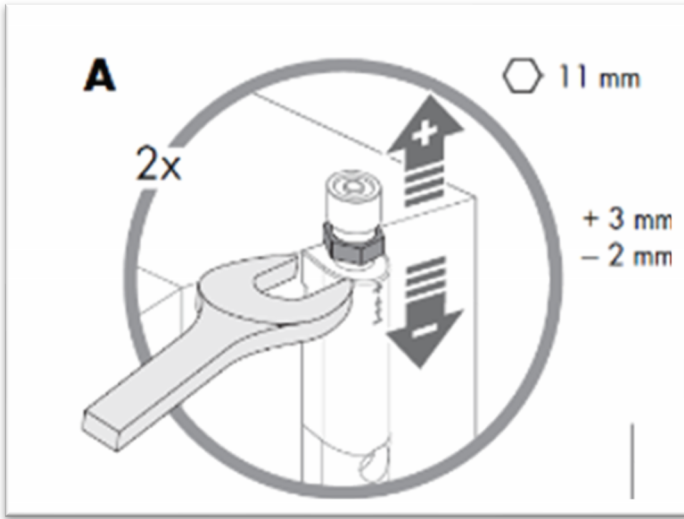

10.7 Lubrication

Red: Use non-resinous grease or oil (e.g. 3 in 1 Oil). Green: Use silicone lubrication for rail track.

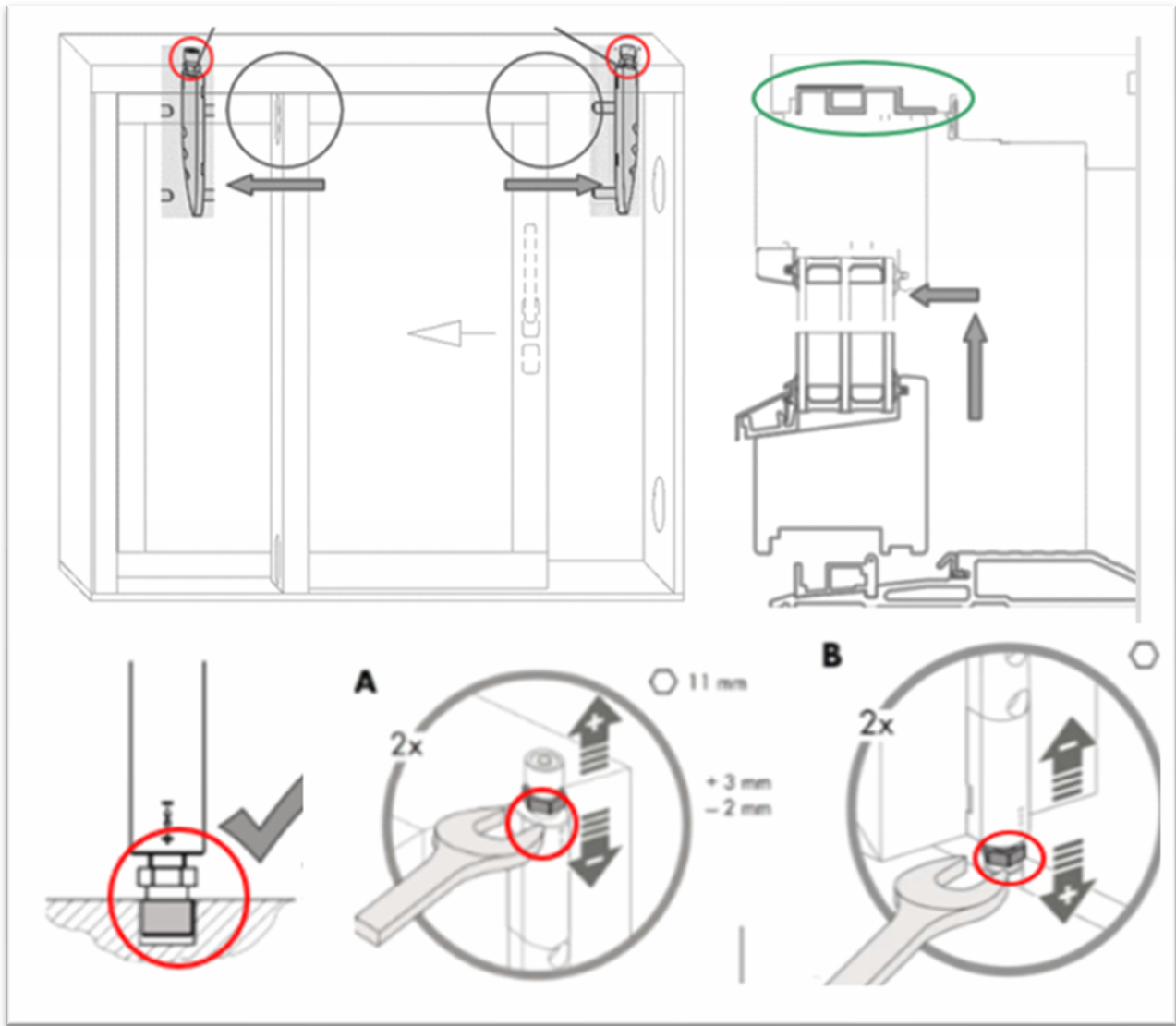

11 Supplemental: Inward Bi-Fold Slide (ELITE HL92)

11.1 How To Operate

IMPORTANT: Review Chapter 1 before reading the additional supplementary information below.

The active sash connects to inward-folding passive sashes using a GU mechanical assembly and hardware. An interior handle activates the multi-point cam locking system. The exterior features either a pull handle or an optional handle with a keyed lock.

Bi-fold systems with an uneven number of fold sashes are equipped with a folding catch, which secures the turn-only sash to the first fold sash. This prevents the turn-only sash from swinging uncontrollably and potentially sustaining damage when opening the entire folding system.

The folding catch consists of a fastener attached to the turn-only sash and catch mechanism itself, which is mounted on the first fold sash.

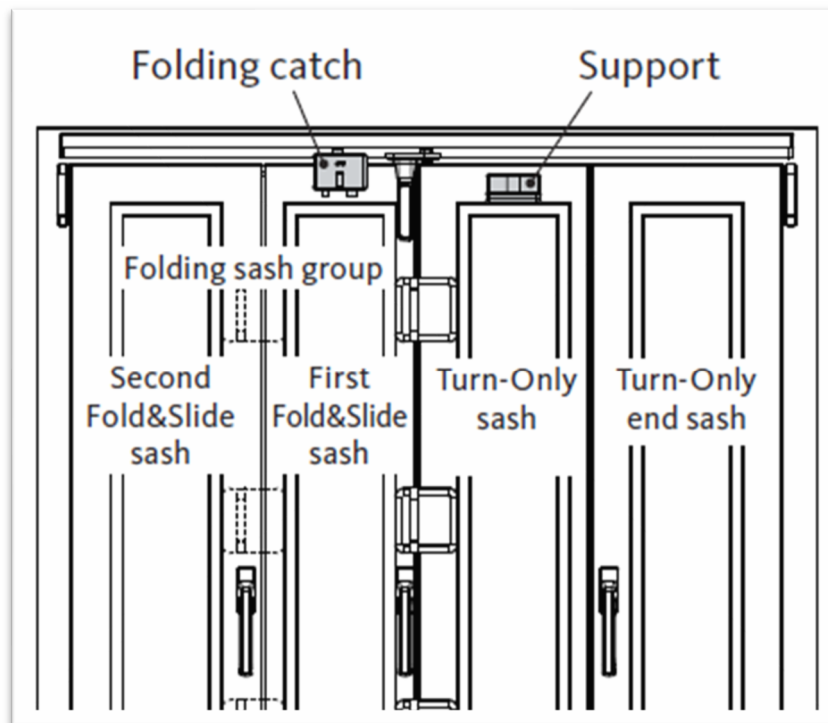

Before opening or closing the fold system, ensure that the turn handles, and rebate levers are in the horizontal open position.

Do not use the turn handle to pull or push one or multiple sash groups.

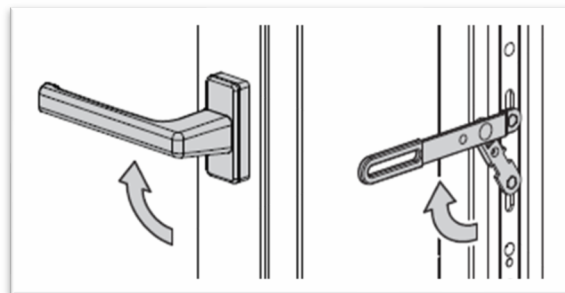

Opening

Open the turn-only sash

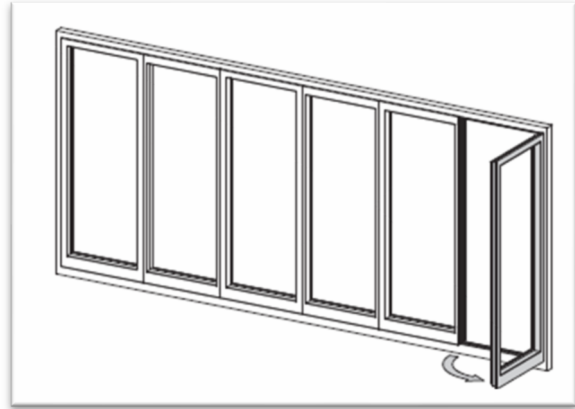

With the turn handles and rebate lever of the turn-only sash and first fold sash in the open position, turn the turn-only sash 180 degrees until it rests against the first fold sash and the fastener engages in the folding catch.

Before opening the first folding sash, ensure the turn-only sash has fully rotate 180 degrees and the fastener is securely engaged in the folding catch. If not properly engaged, the first folding sash and subsequent sashes cannot be opened.

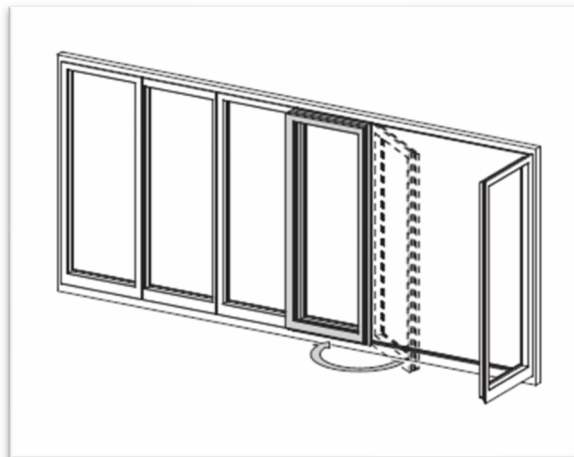

With the turn handles or rebate levers of the first- and second-fold sashes in the open position, grip the turn handle of the second fold sash and pull the folding sash group (first- and second-fold sashes) into the open position.

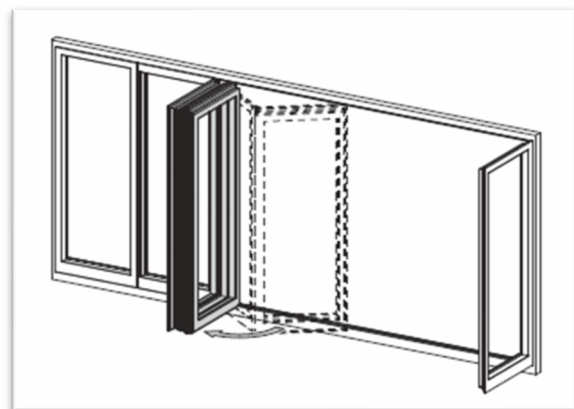

Closing

To move the rearmost folding sash group into the closed position:

- First, pull all other folded sash groups toward the closed position, holding only the sashes on the roller side.
- Turn the turn handles or rebate levers of the fold sash group that has just been moved into place.
- Once in the closed position, turn the handles or rebate levers to the locked position.
- Repeat this process for each fold sash group consecutively.

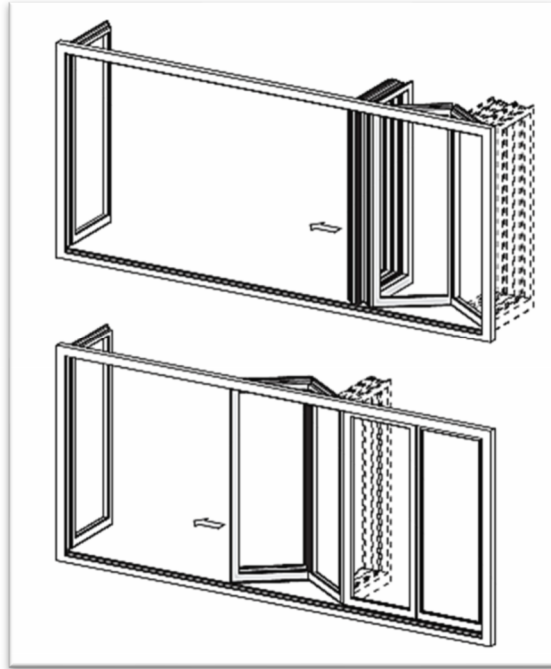

For systems with a folding catch, when the last folding sash group is closed, the folding catch releases the Turn-Only sash.

- Move the Turn-Only sash to the closed position.
- Turn the handle or rebate lever to the closed position.
- Secure the Turn-Only sash in the locked position.

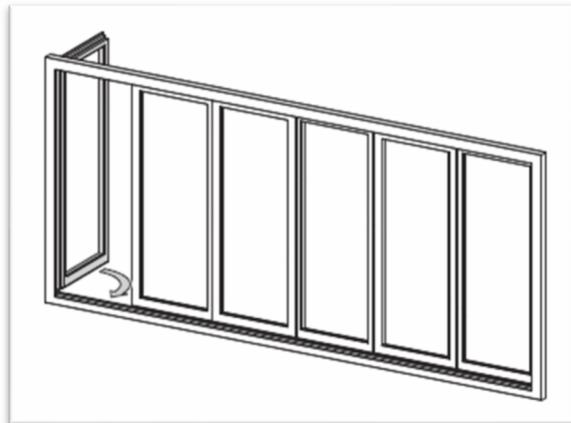
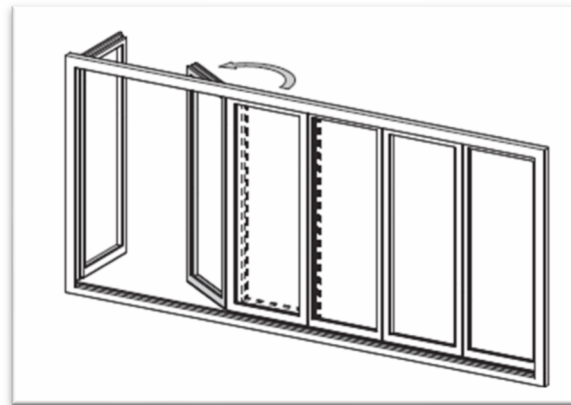

11.2 Design Considerations

Critical Clearances

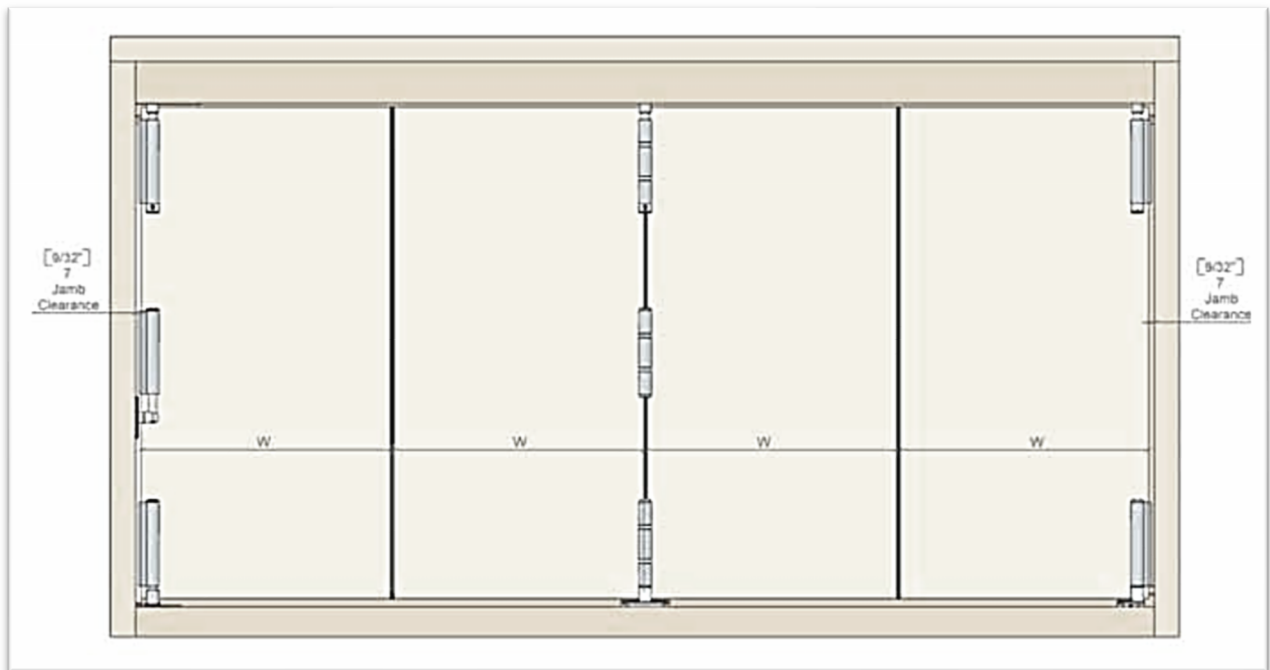
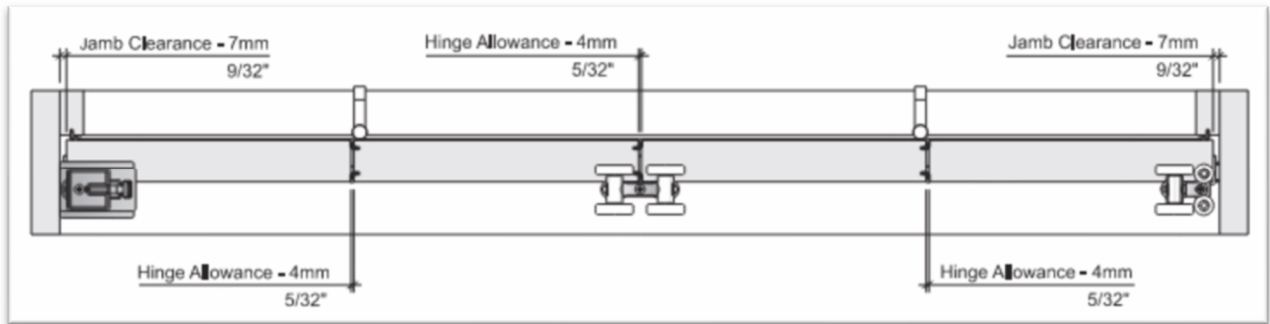

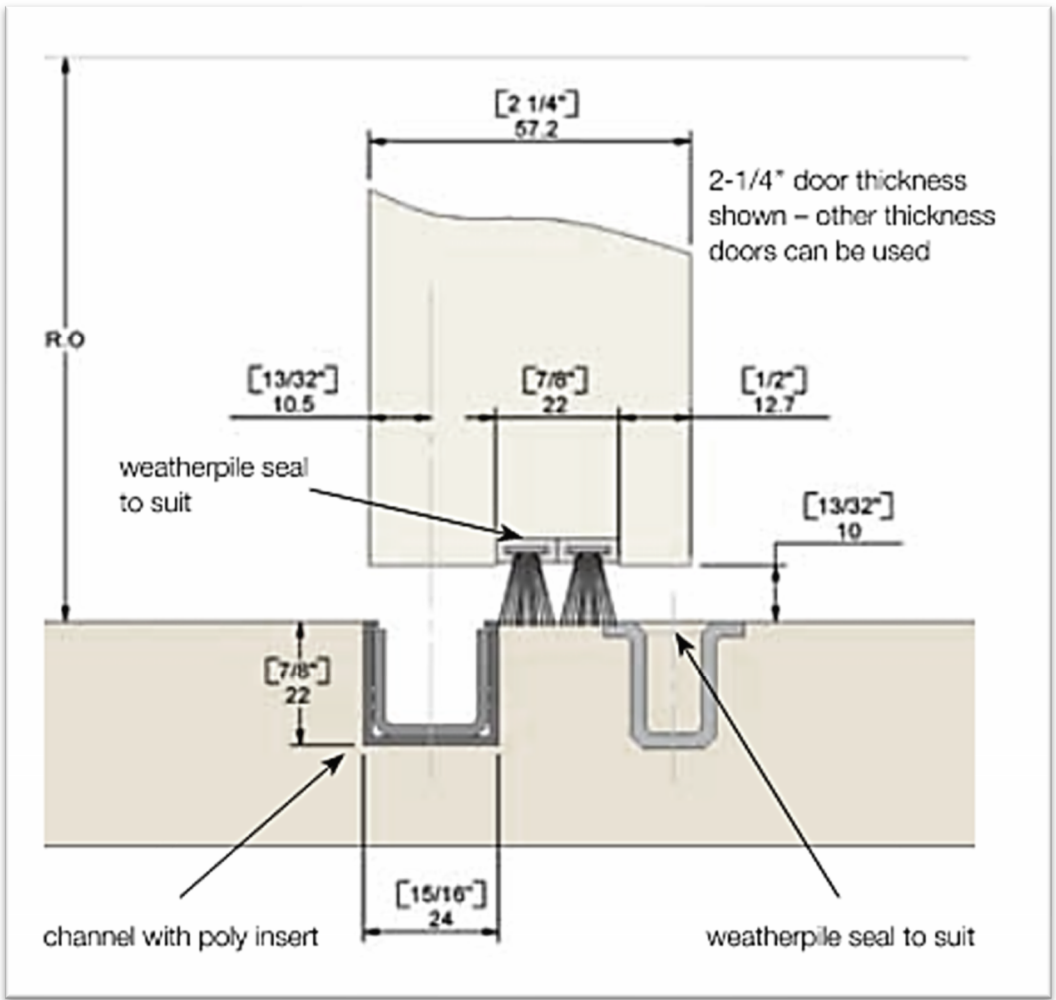

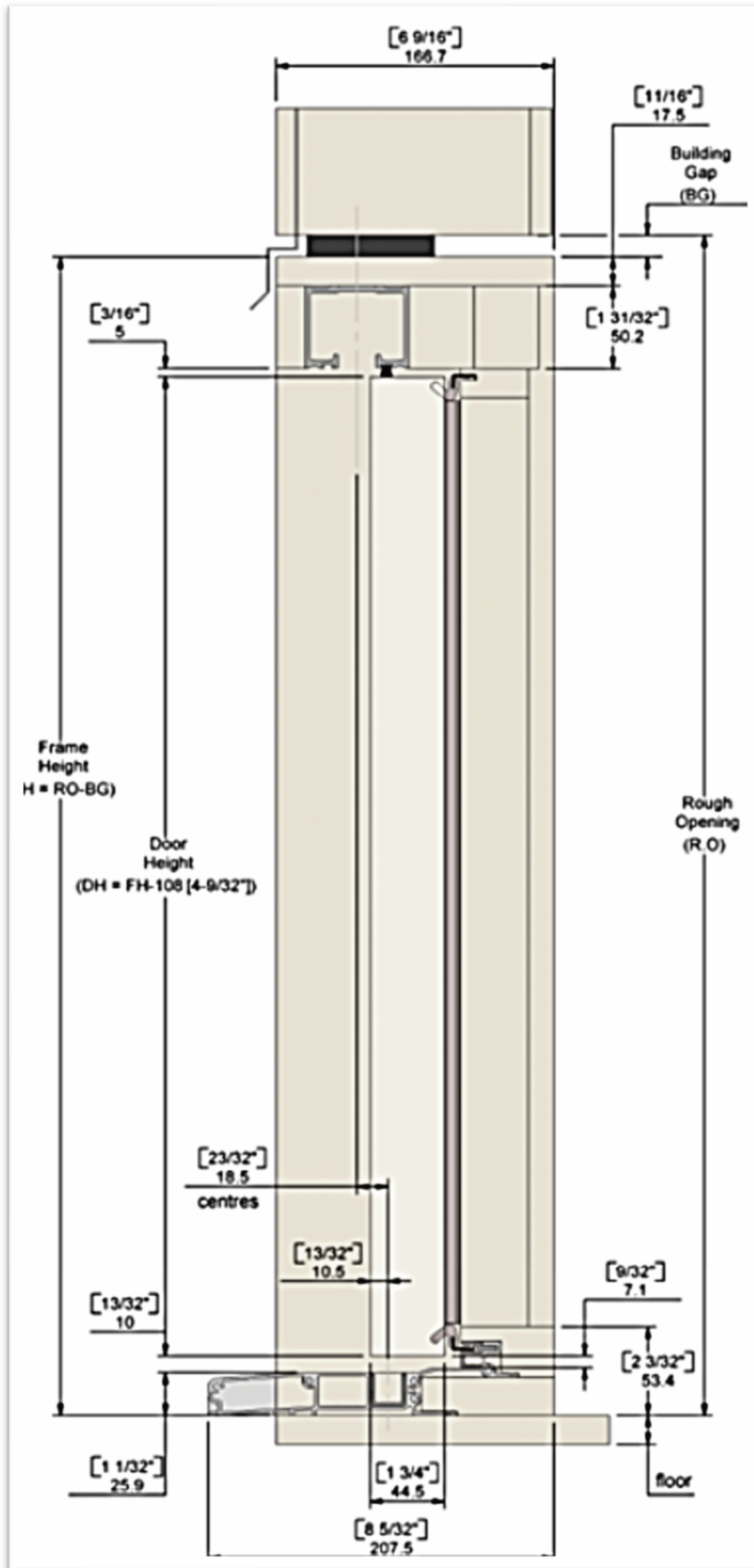

11.3 Fixing Points

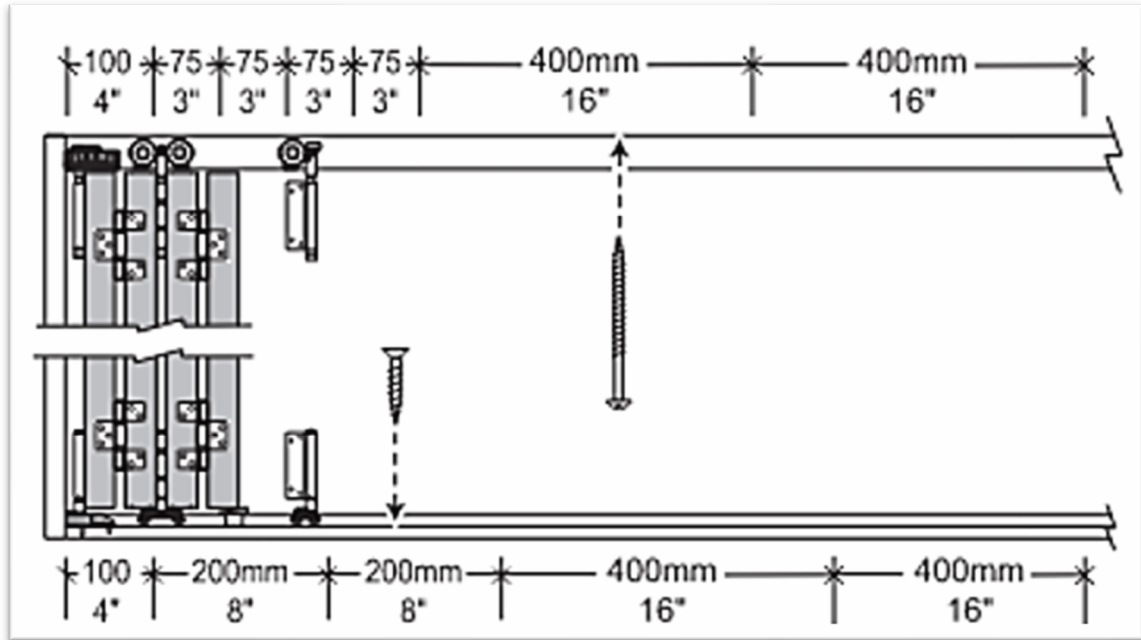

11.4 Operable Sash Removal & Install

First, familiarize yourself with the hardware and basic components shown in the graphics below.

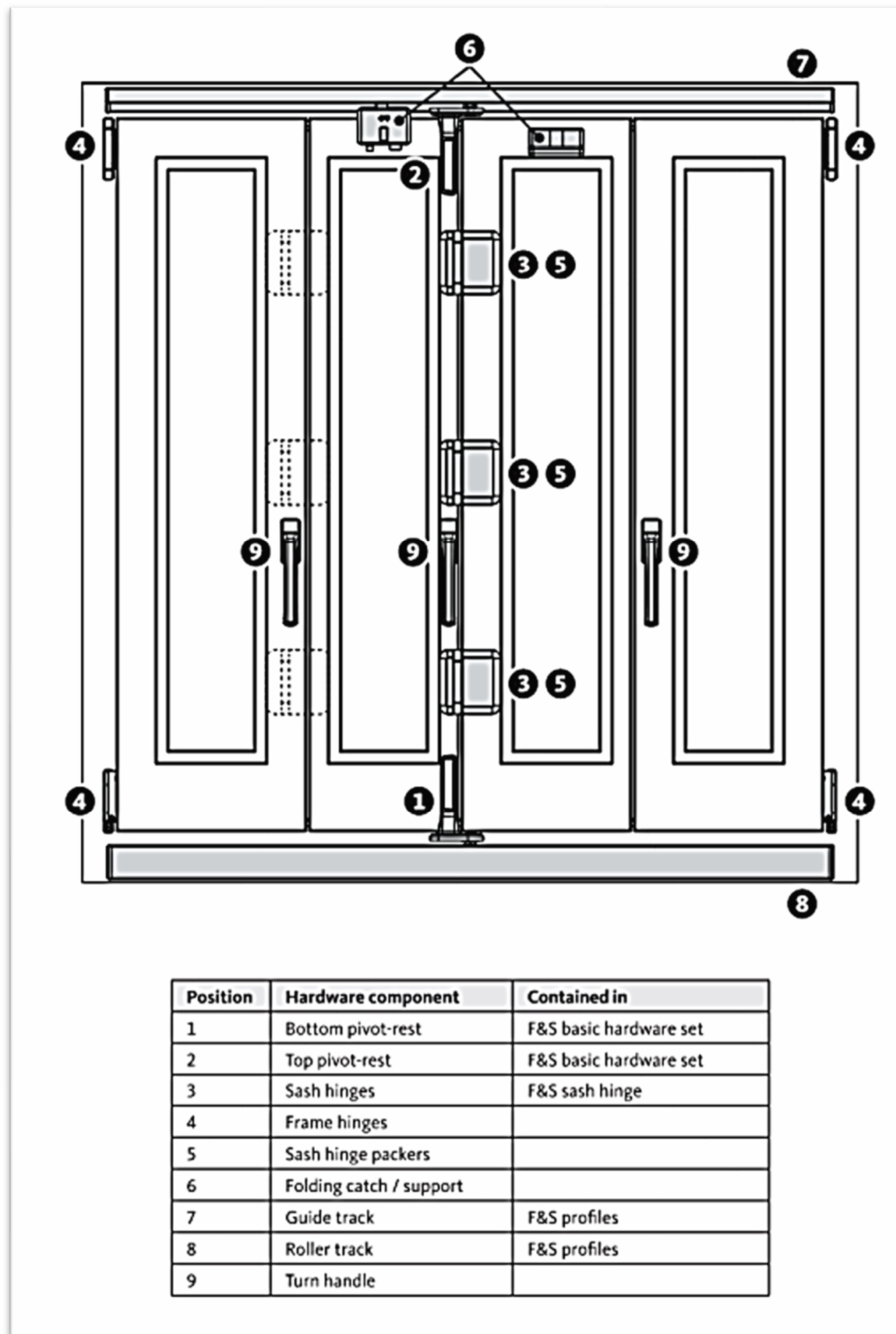

Fold Sash Configurations

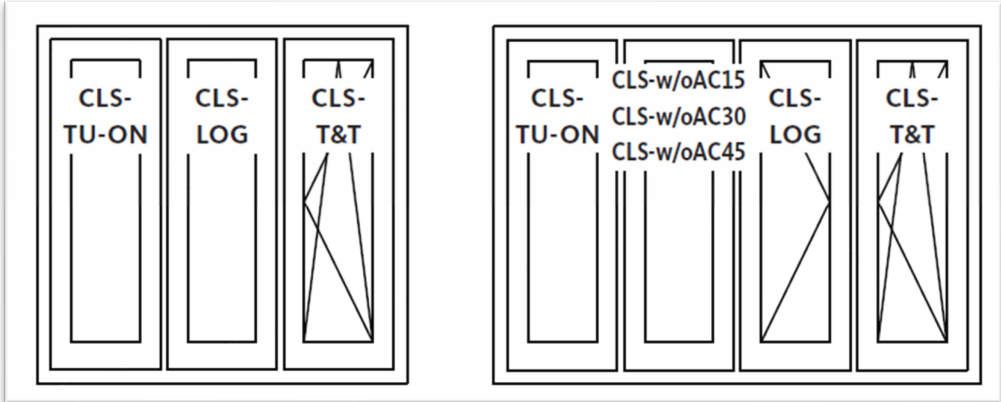

Frame Hinge Positions based on above Fold Sash Configurations

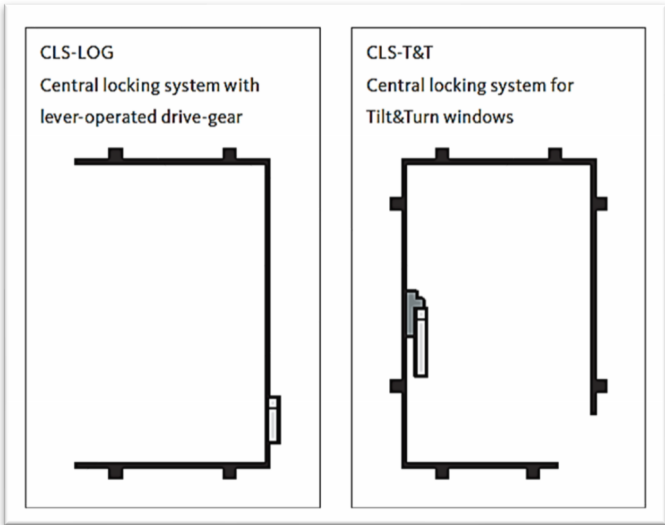
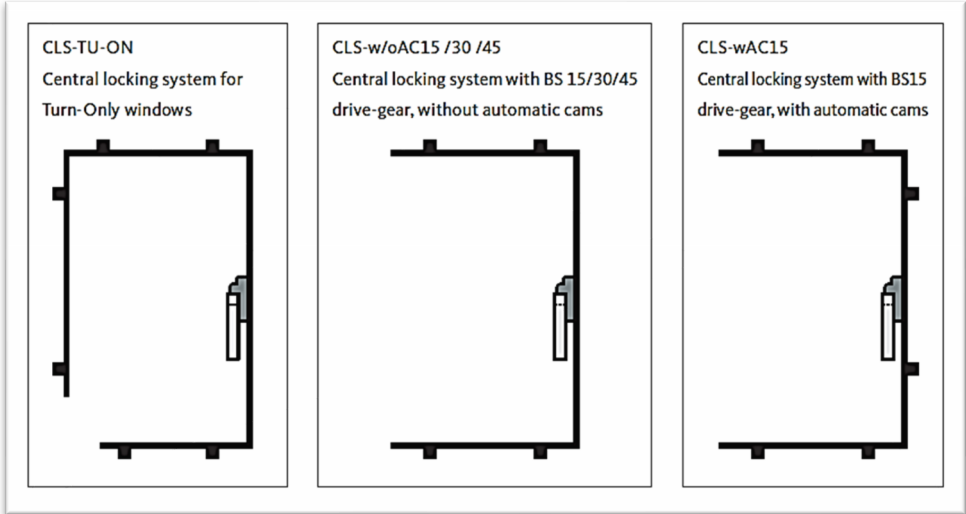

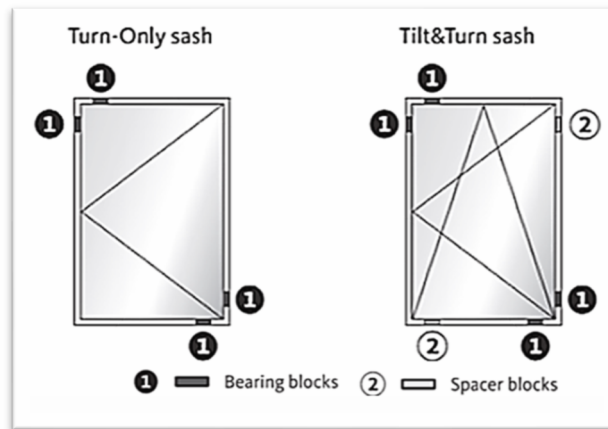
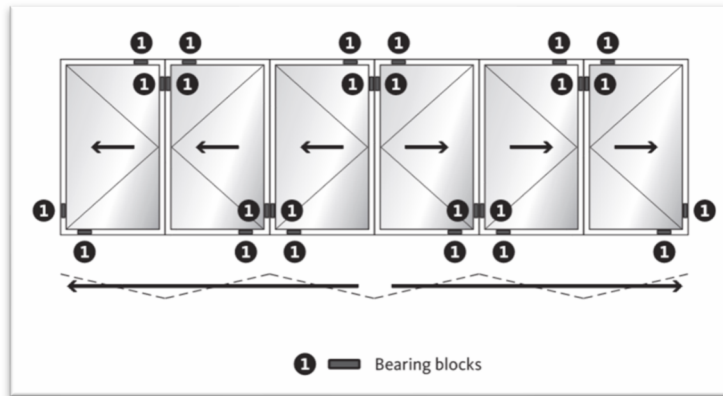

The following provides installation guidance (for removal, follow the steps in reverse). Refer to the adjustments section for instructions on loosening or tightening the hinges.

- Attach the fold sash to the already installed sash and align the hinges. Push the hinges into one another.
- Attach the fold sash to the already installed sash and align the hinges. Push the hinges into one another.
- Ensure the pins fully engage and lock into place.

Installing the pin in the sash hinge

Long side to right

Long side to left.

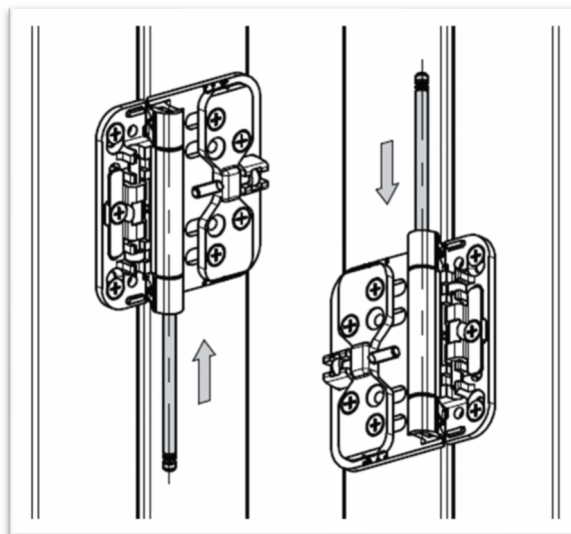

- Push the lower pivot rest of the fold sash onto the bogie (1).
- Use a size 17 open-end spanner to tighten the bogie locknut (2), ensuring the sash is secure and does not slip out.

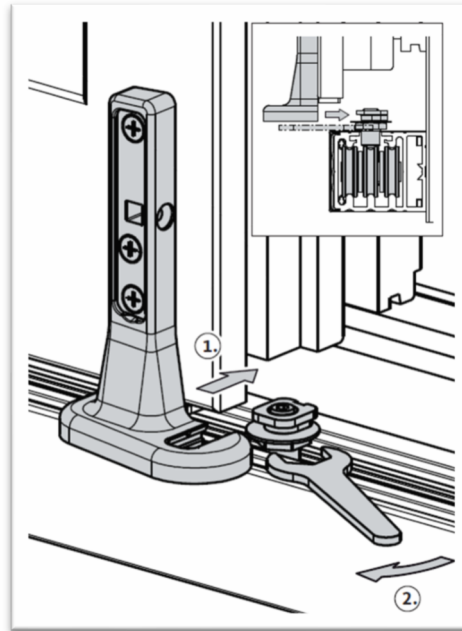
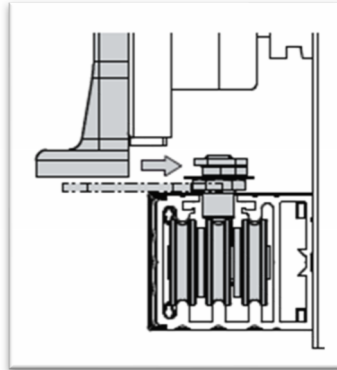

- Push the upper pivot rest of the fold sash onto the guide roll (1).
- Use a size 17 open-end spanner to tighten the locknut on the guide roll (2) to secure the fold sash and prevent it from slipping out.

Depending on the size of the sashes, the upper pivot-rest can be inserted more easily with the sashes open.

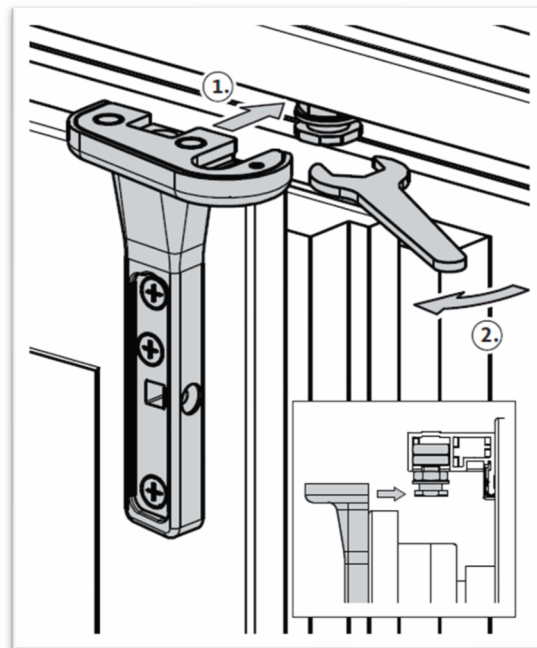
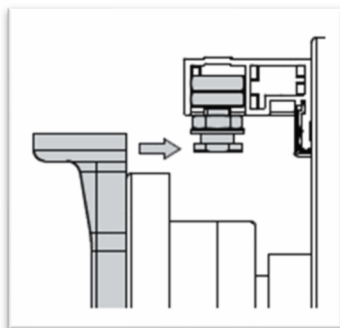

After installing each individual fold sash, adjust the gap between the threshold and frame rebate to match the specified dimensions for the fold sash configuration noted earlier in this section. Refer to the adjustment section below for guidance.

Additionally, after installing each fold sash, check the frame hinges of the first fold sash and readjust if necessary. Instructions for adjustments can be found in the adjustment section below.

Hinge Cover Removal

1. Loosen the set screw by turning counter-clockwise with a hexagon spanner

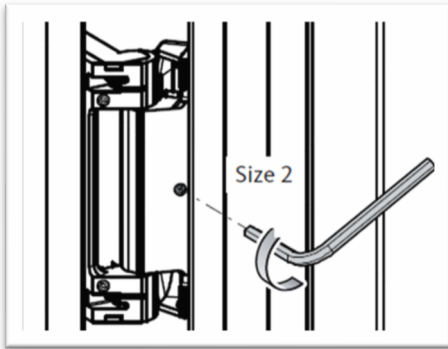

2. Pull the small cover off

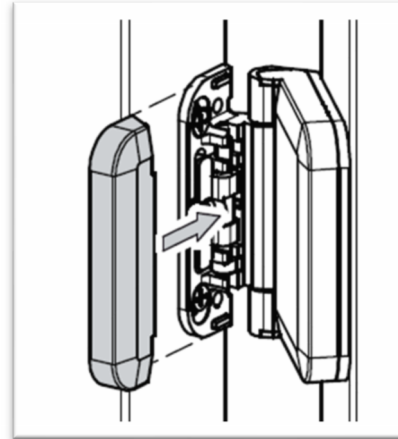

3. Unscrew the two sets of screws by turning counter-clockwise with a hexagon spanner

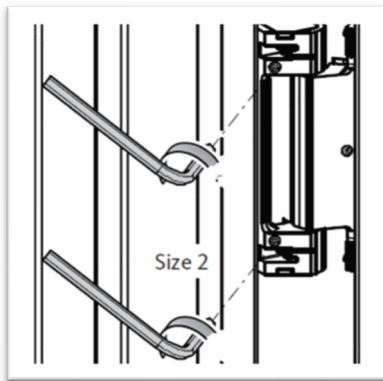

4. Pull the large cover from the hinge side off

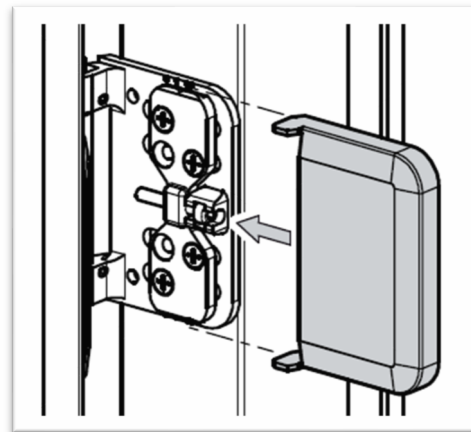

Pivot-Rest Cover Removal

- Pull out (3) small cover at bottom of pivot-rest.
- Unfasten long cover by unscrewing the screw (2)
- Pull the long cover (1) off

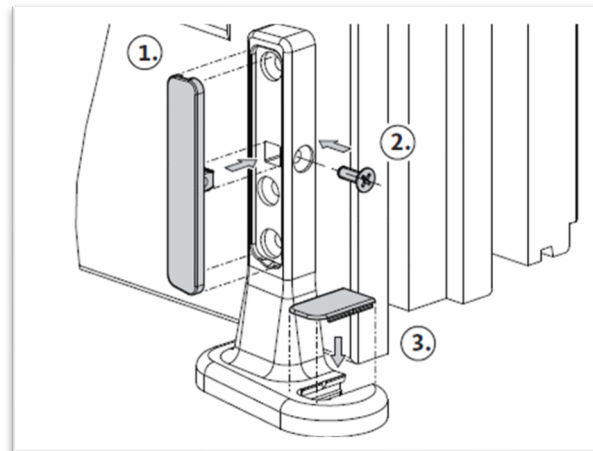

Track Cover Removal

1. Remove side covers of roller track

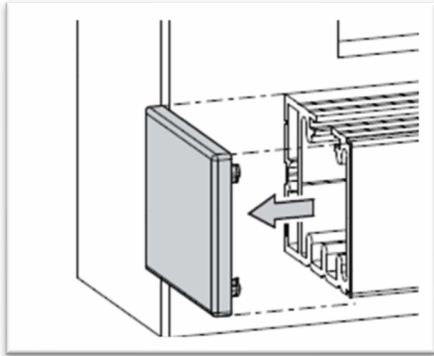

2. Slide a thin flat screwdriver or a plastic/wood wedge into the gap at the top between the roller track and the cover profile at one end of the roller track. Gently loosen it bit by bit, then carefully pull the cover off. Avoid using excessive force to prevent damage to the cover.

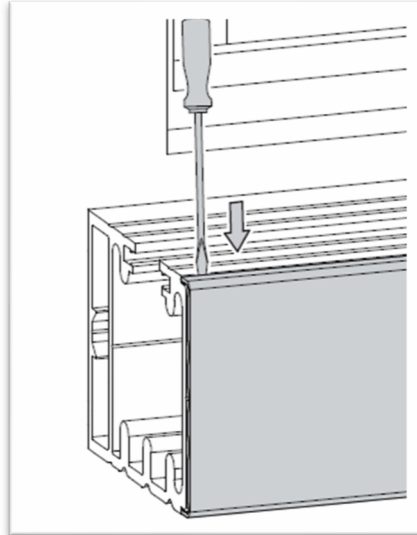

3. Remove side covers from guide track

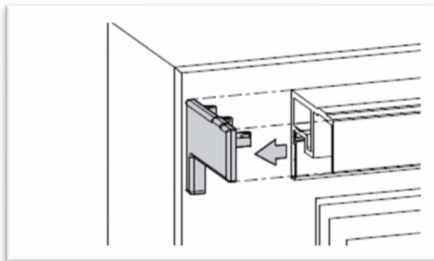

4. Slide a thin flat screwdriver or a plastic/wood wedge into the gap at the top between the guide track and the cover profile at one end of the guide track. Gently loosen it bit by bit, then carefully pull the cover off. Take care not to damage the cover.

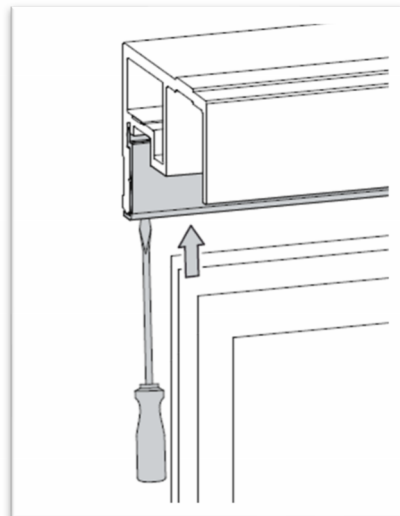

11.5 Plumb, Level & Square Assessment and Adjustment

Adjusting the Bogie and Guide Roll

The gap between the threshold and frame rebate and the gasket pressure of a fold sash can be adjusted at the bogie and guide roll as follows:

- Move the fold sash, already installed, carefully into closed position.
- Undo locknut of bogie on fold sash to be adjusted using open-end spanner (size 17)
- Adjust gap between threshold and frame rebate by turning set screw with hexagon spanner (size 4) - set screw can be adjusted from -1 mm to $+3.5$ mm.
- Adjust gasket pressure by sliding the pivot-rest.
- Tighten locknut again with open-end spanner (size 17) (tightening torque: 15 Nm).
- Undo locknut on guide. Roll the slide-fold sash to be adjusted using the open-end spanner (size 17).
- Adjust height of guide roll by turning set screw with hexagon spanner (size 4) so guide roll cannot scrape against guide track. Adjustment range 1mm to $+3.5$ mm.
- Adjust gasket pressure by sliding pivot-rest.

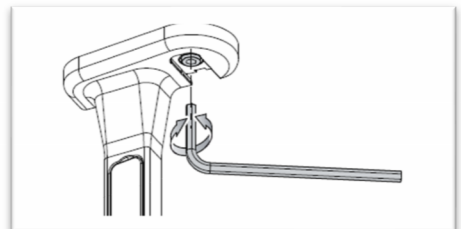
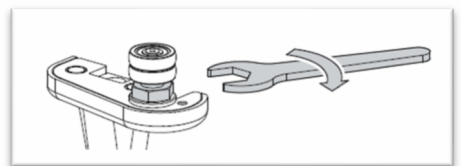
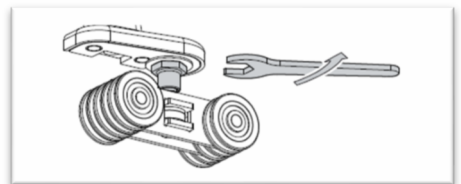
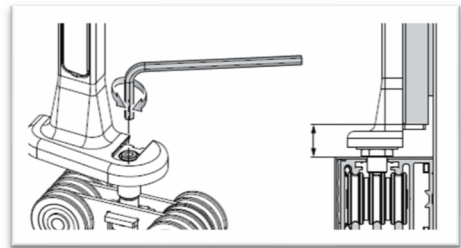
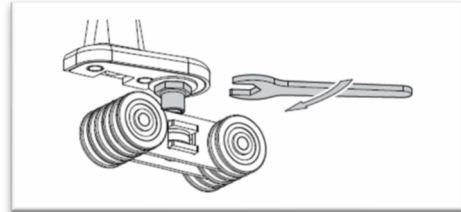

- Tighten locknut again with open-end spanner (size 17) (tightening torque: 15 Nm).

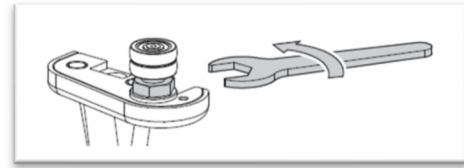

Adjusting Sash Hinges

The vertical alignment of the fold sashes and the size of the shadow gap between them can be adjusted at the hinges.

 The diagram shows a side view of a sash hinge assembly. Two circular callouts provide detailed views:

- The top callout shows a scale with markings at 10, 5, 0, and 1.5. A downward-pointing arrow indicates the adjustment range.
- The bottom callout shows two screws with a dimension line between them labeled "Distance between screws 5,5 mm".

 Below the diagram is a table with the following data:

Hinge	Adjustment range	Neutral position ± 0 on base plate scale	
		Neutral position ± 0 on base plate scale	distance between screws
20/50	-5 to +1.5	0	5.5 mm
20/35*	-5 to +1.5	0	5.5 mm

* Adjusting plate turned through 180°

To adjust the vertical position of the fold sashes relative to one another and the shadow gap between them, turn the set screws at the hinge (see the **Adjustment of the Hinge** diagram below).

Always adjust set screws **1 and 2** one at a time. Loosening all screws at once may damage the sash hinge.

To align the fold sashes vertically:

- Slightly loosen the two screws **1a** to allow movement between the hinge and sash **1**.
- Adjust the vertical position of the sliding panel by turning set screw **1**.
- Retighten the two screws **1a**.

To adjust the shadow gap between the fold sashes:

- Slightly loosen the four screws **2a** to allow movement between the hinge and sash **2**.
- Adjust the shadow gap by turning set screw **2**.
- Retighten the two screws **2a**.

Adjustment of the hinge

Long side of the hinge on the right

Set screw 1		
Rotational direction of set screw	Direction of movement of sash 2	Max. adjustment range
RH (clockwise)	upwards	+2
Left (counter-clockwise)	downward	-2

Set screw 2		
Rotational direction of set screw	Direction of movement of sash 2	Max. adjustment range
right (clockwise)	to the right (shadow gap increases)	+1,5
Left (counter-clockwise)	to the left (shadow gap decreases)	-5

Long side of hinge on left

Set screw 1		
Rotational direction of set screw	Direction of movement of sash 2	Max. adjustment range
RH (clockwise)	downward	-2
Left (counter-clockwise)	upwards	+2

Set screw 2		
Rotational direction of set screw	Direction of movement of sash 2	Max. adjustment range
right (clockwise)	to the left (shadow gap increases)	+1,5
Left (counter-clockwise)	to the right (shadow gap decreases)	-5

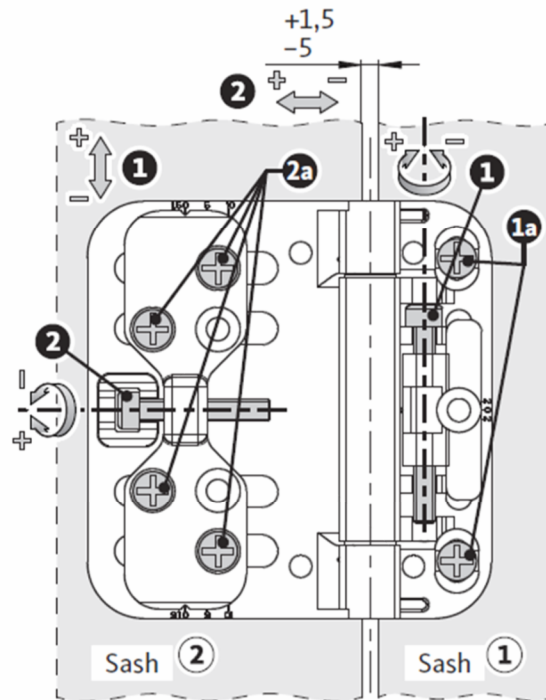

Checking Hinge Settings

Each time you adjust the hinges, check afterwards that they are uniformly aligned.

- Make sure the test dimension shown in the figure below is identical at all three hinges of the sash.
- If this is not the case, adjust height of fold sashes relative to one another again at the set screw 1 until all three test dimensions are the same.

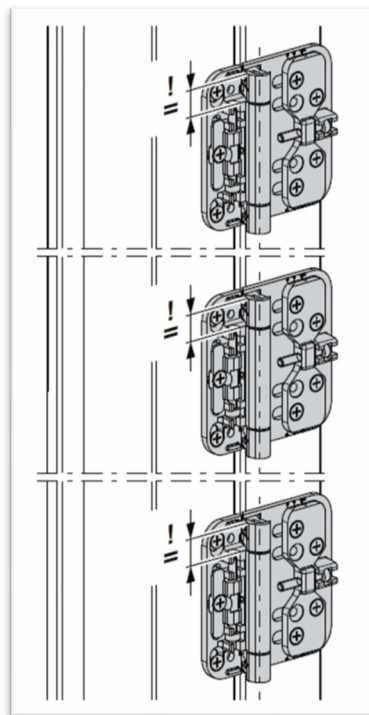

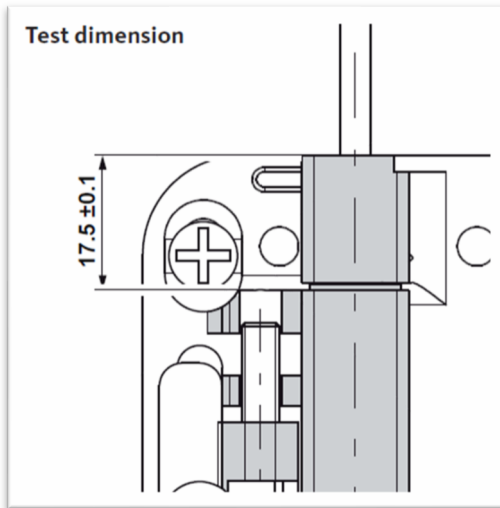

- Make sure, using a straight edge or a long level, that the lateral edges of long sides of all three hinges on the sash are flush.
- If one of the hinges does not line up with the other two, turn the adjusting screw **2** until it does line up.

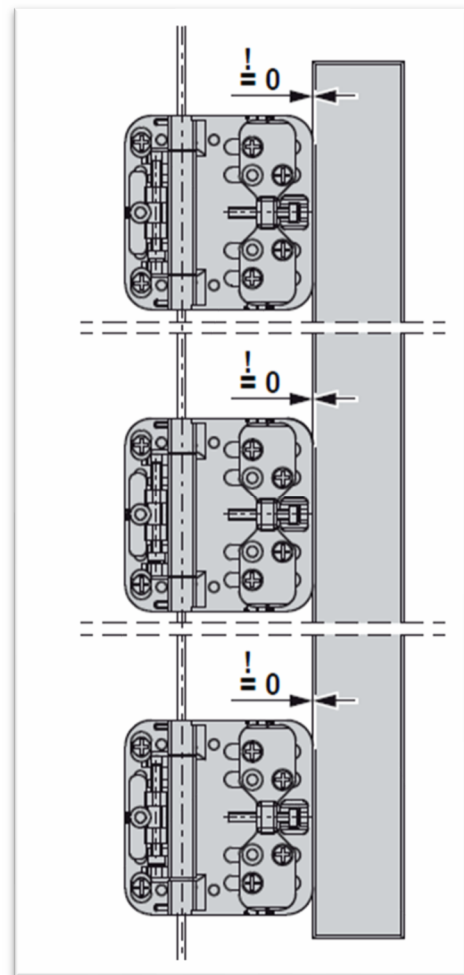

Adjusting Gasket Pressure

You can increase or reduce the gasket pressure using a Torx wrench T15, as shown below.

- Adjust gasket pressure at the upper locking point on locking side (at sash).

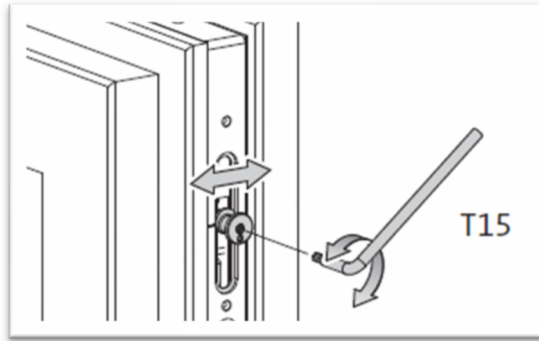

- Adjust gasket pressure at other locking points on underside of sash.

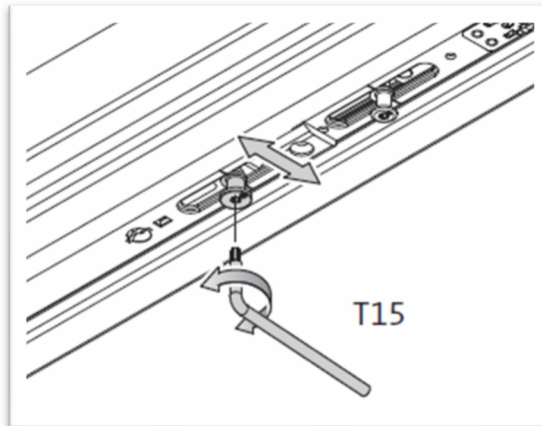

- Adjust gasket pressure at side of sash at top.

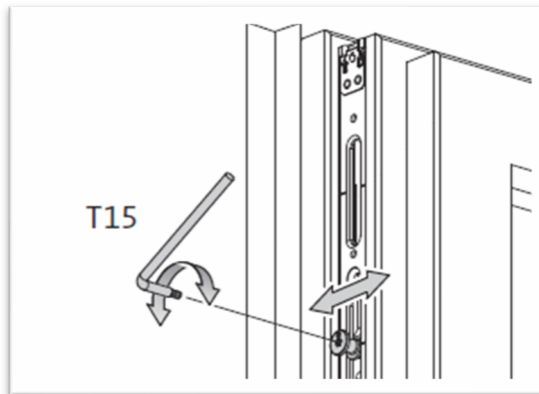

11.6 Lubrication

You do not need to lubricate the bogie and guide roll axles and hinges.

12 Supplemental: Outward Bi-Fold Slide (ELITE HV92)

12.1 How To Operate

IMPORTANT: Review Chapter 1 before reading the additional supplementary information below.

The active sash connects to outward folding passive sashes using a Centor mechanical assembly and hardware. A multi-point cam locking system is engaged by an interior handle for secure closure.

This bi-fold door includes an exterior handle with a keyed lock.

When there is only one exterior handle, it is placed on the exit door, where a passage set, or additional lock is not required. To secure the door from the inside, use the drop bolts at the top and bottom.

Note: In this configuration, the exit door cannot be accessed from the exterior.

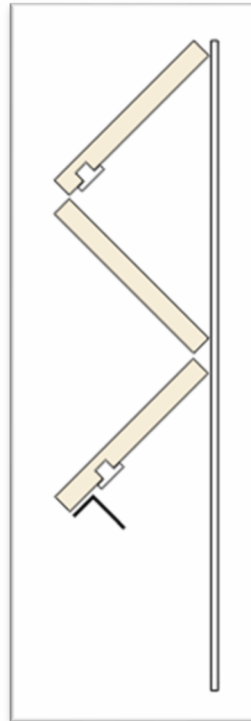

12.2 Design Considerations

IMPORTANT: Review Chapter 2 before reading the additional supplementary information below.

Placement and Rough Opening

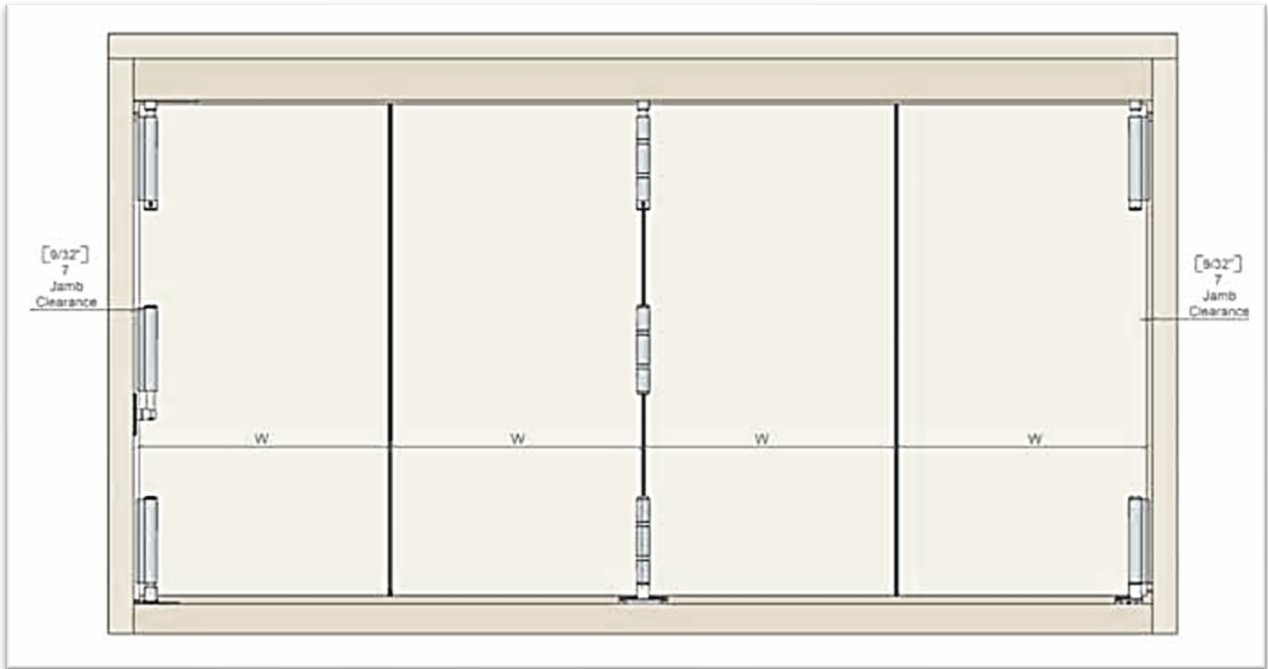
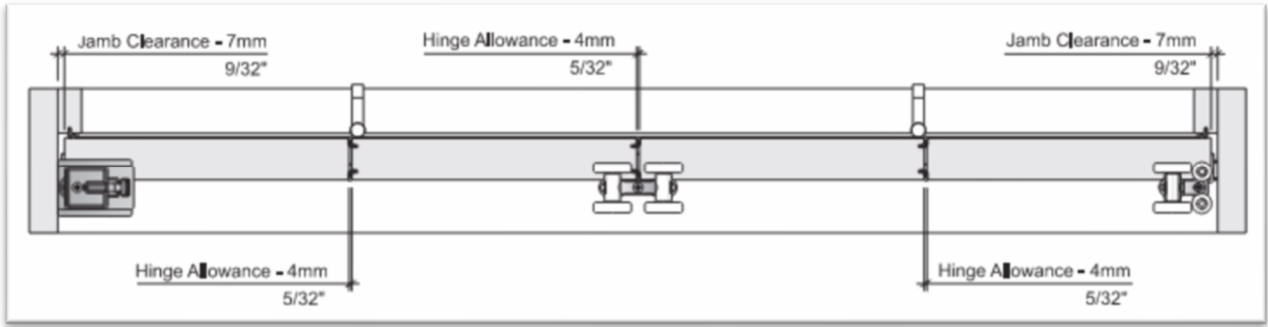

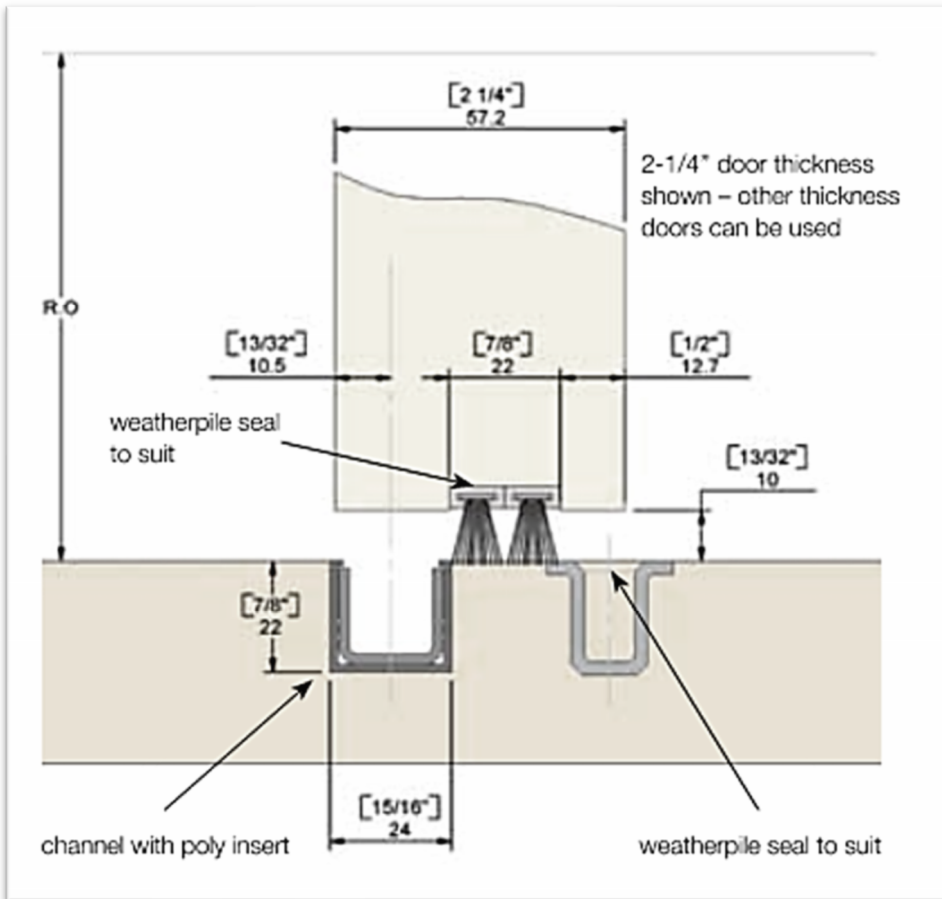

Flush with floor
channel sill
option

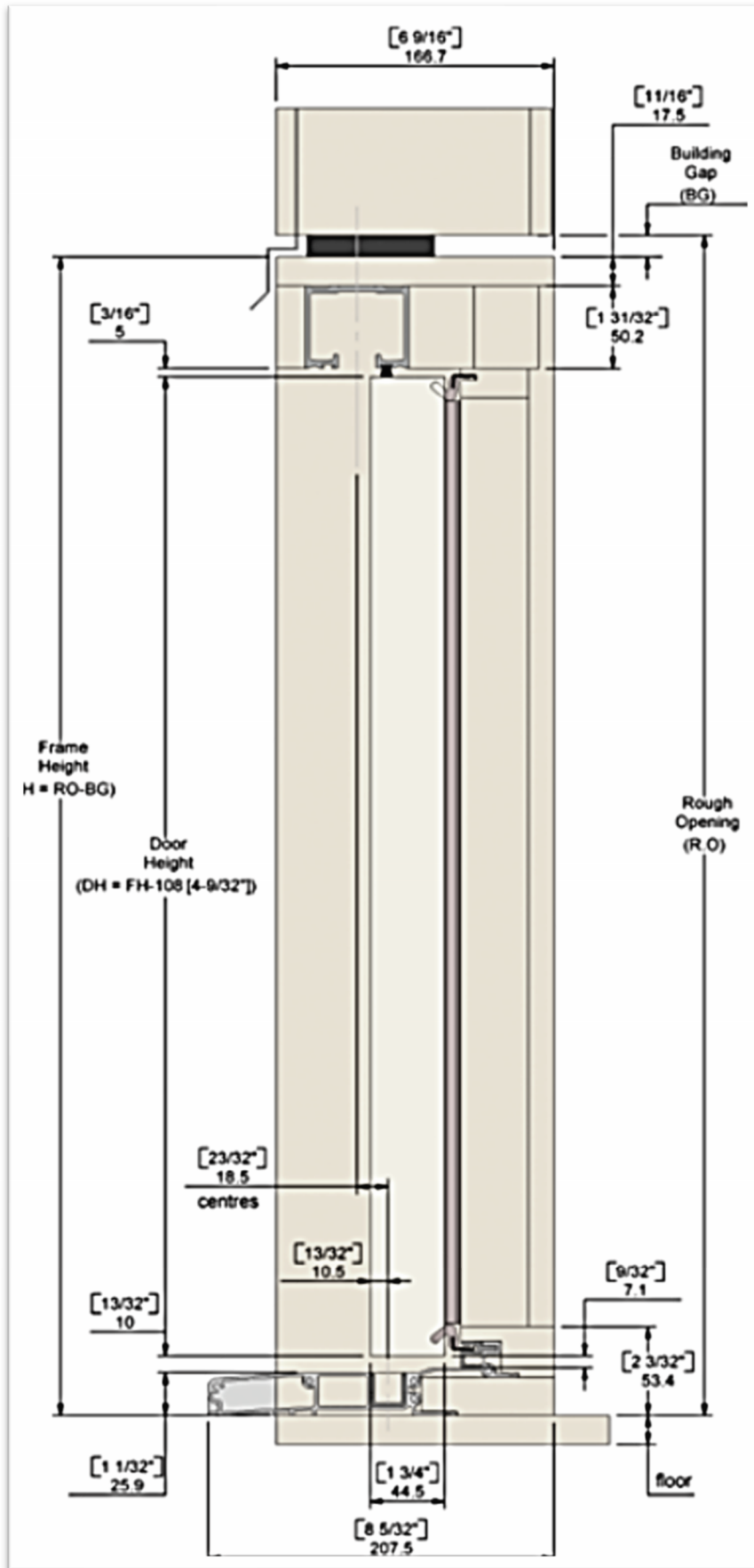

12.3 Fixing Points

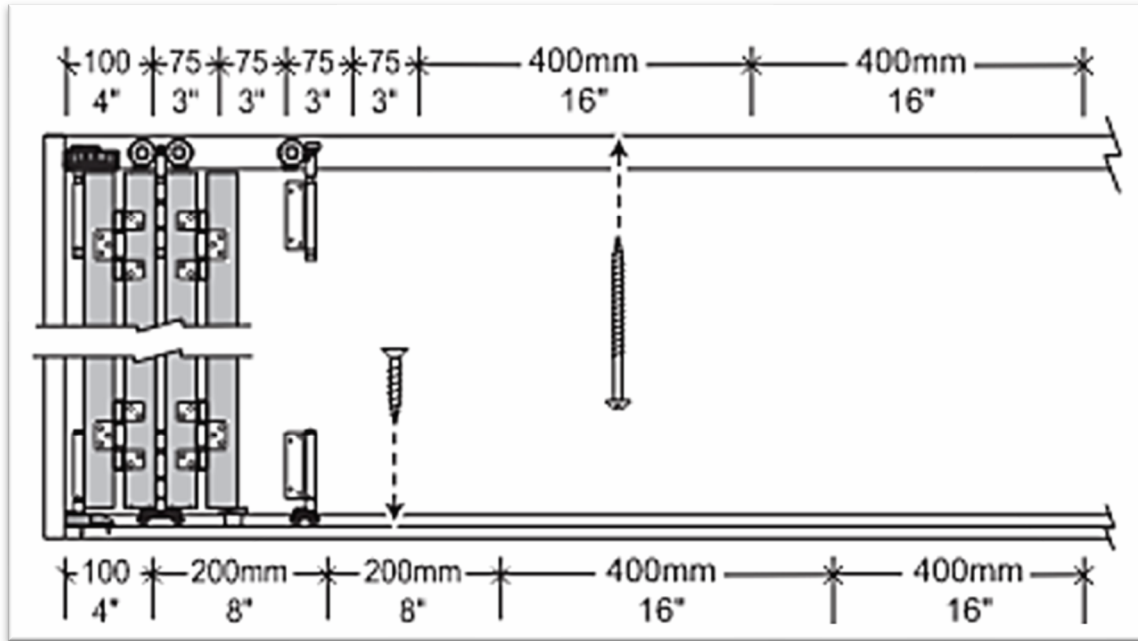

12.4 Operable Sash Removal & Install

First, familiarize yourself with the hardware and basic components in the graphics below.

Common panel layouts

Hardware legend	
PS pivot set	RCS right carrier set
WPS wall pivot set	HHS half offset hinge set
ICS intermediate carrier set	HS hinge set (straight)
LCS left carrier set	DB dropbolt
IPH internal pull handle	EH external handle

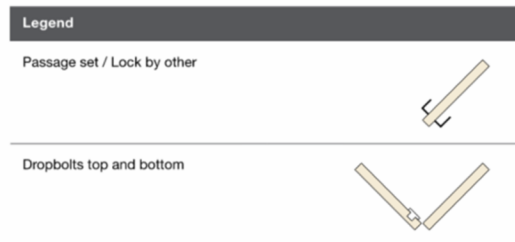

> Note: Wall Pivot Set recommended for doors over 2250mm in height.

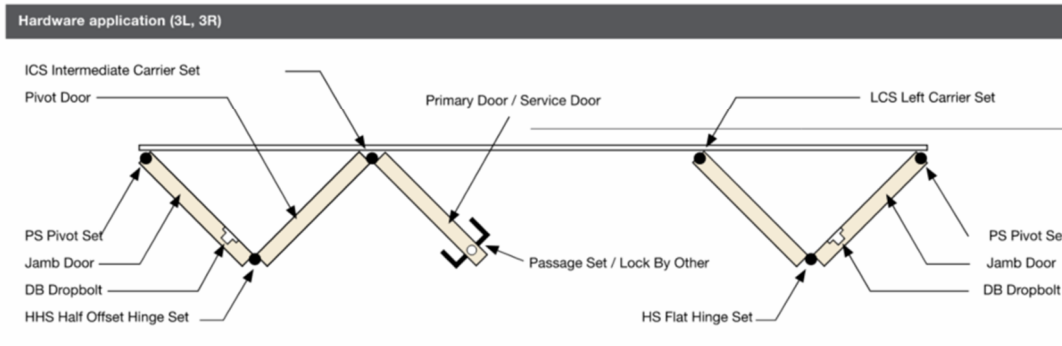

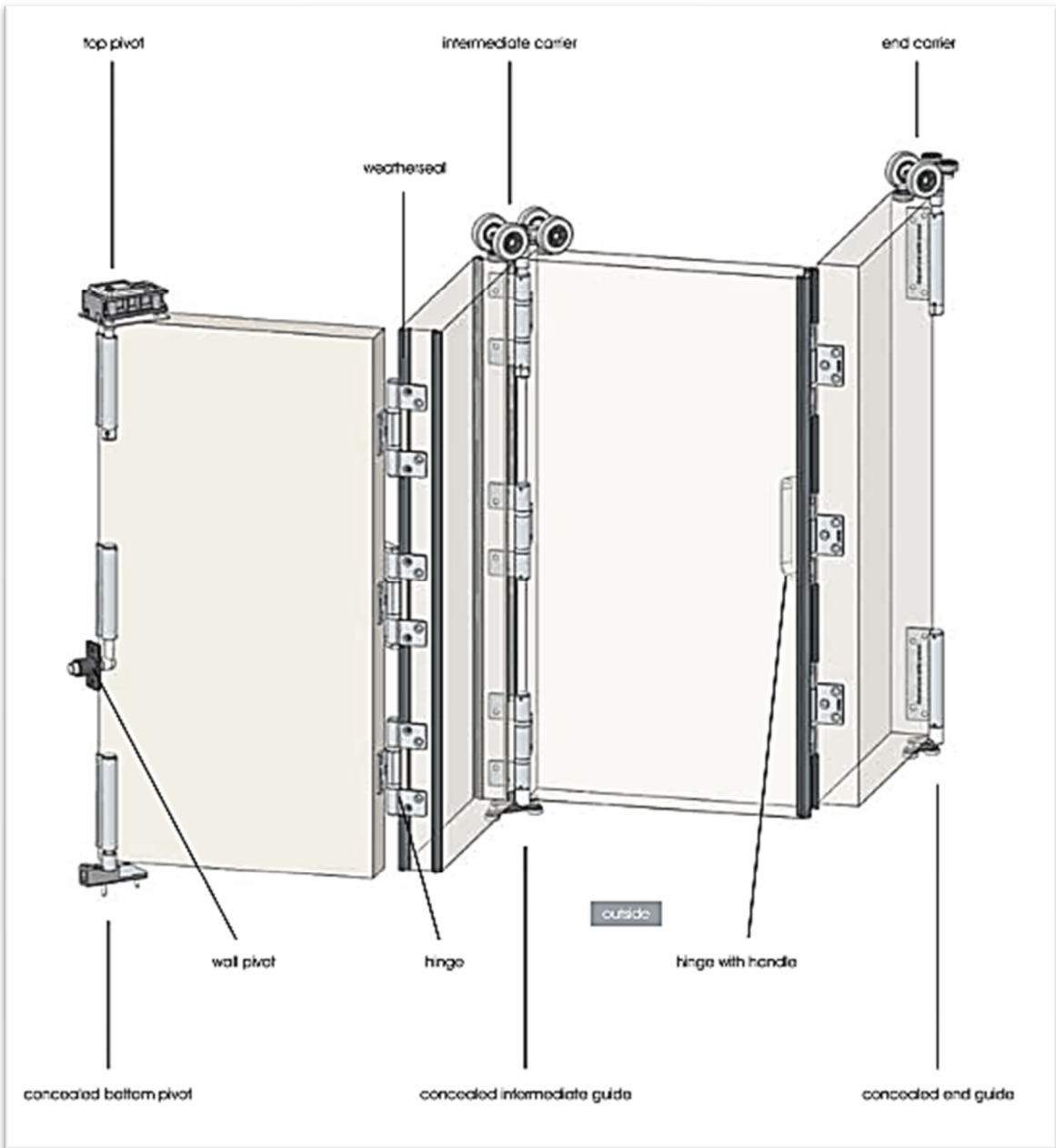

For Bi-Parting Sets

Track Fixing & Clearance

Punch and drill hole 5mm (3/16")

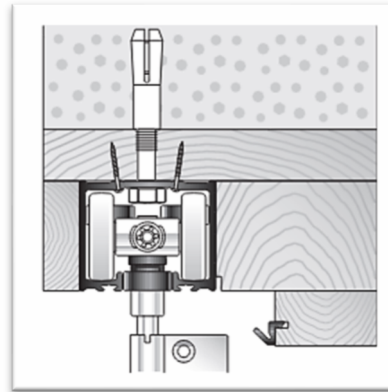
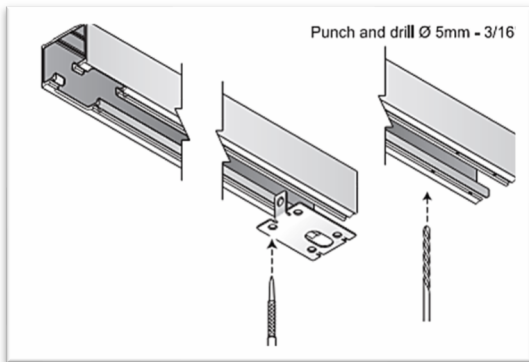

Front Alignment

Channel fixing for Drainage.

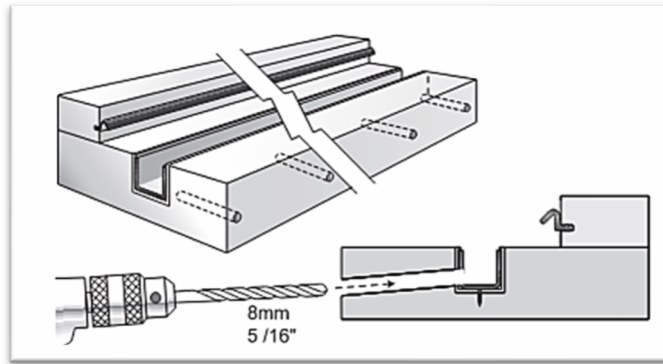
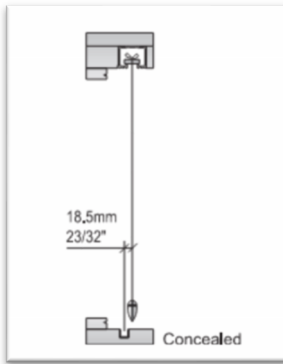

Wall Pivots

Perimeter Seal

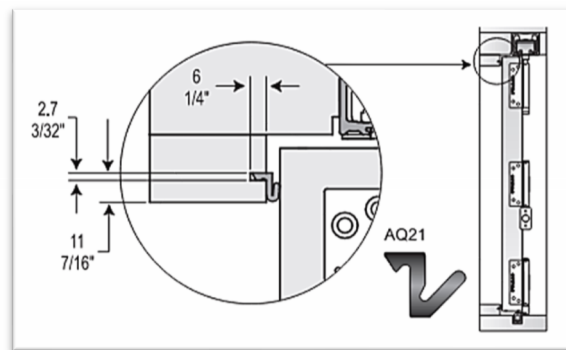
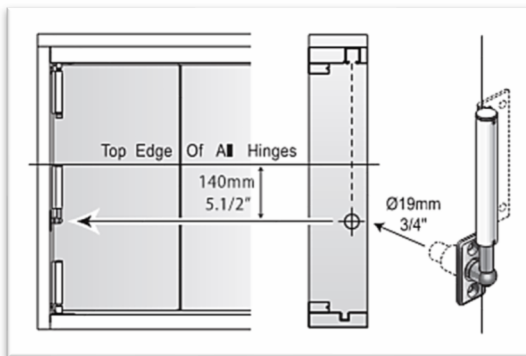

Panel Orientation

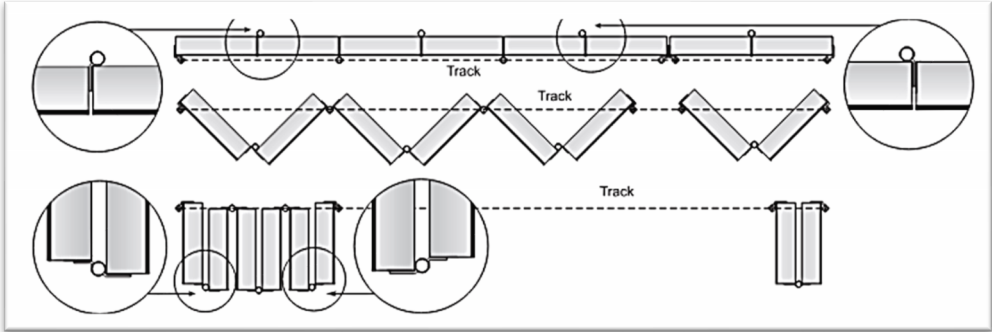

Hinges, Carriers and Guides

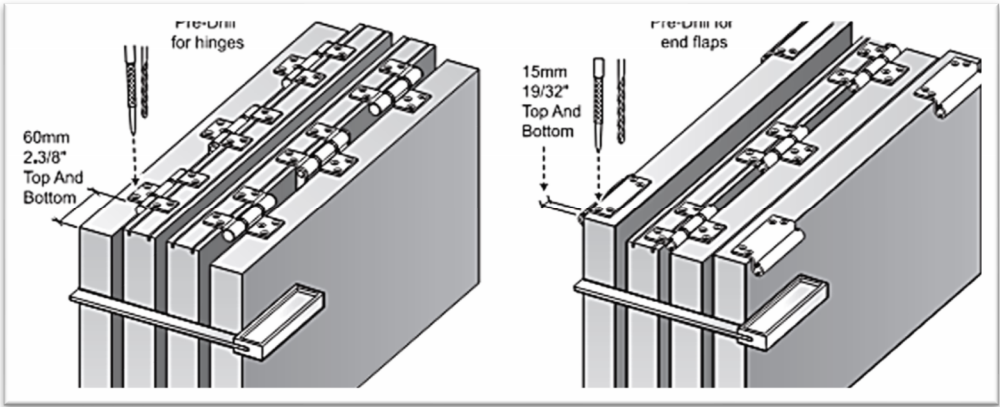

Assembly & Disassemble Hinge Panels

Installing Hardware

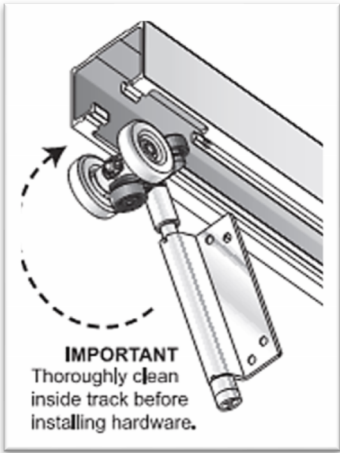
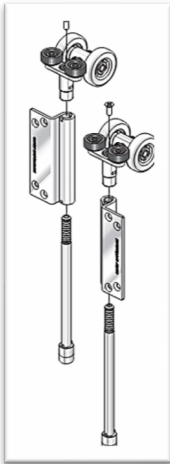

Hardware Orientation

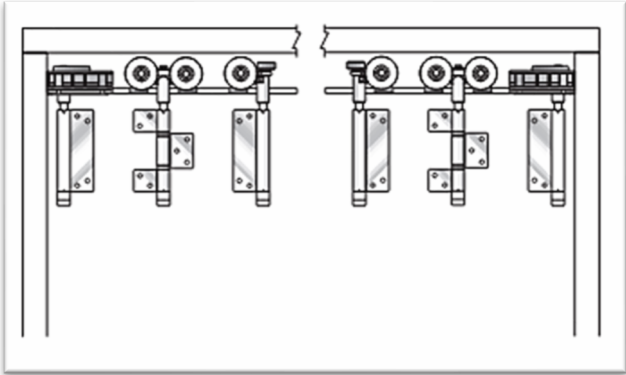

Top Pivot Block

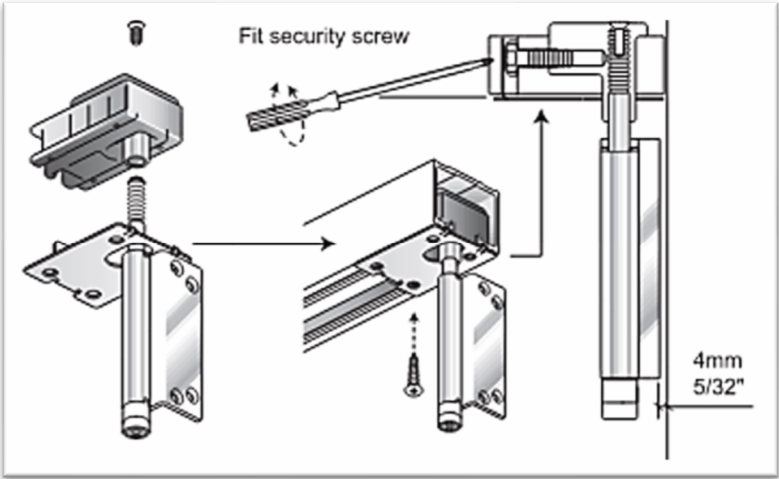

Bottom Pivot Block

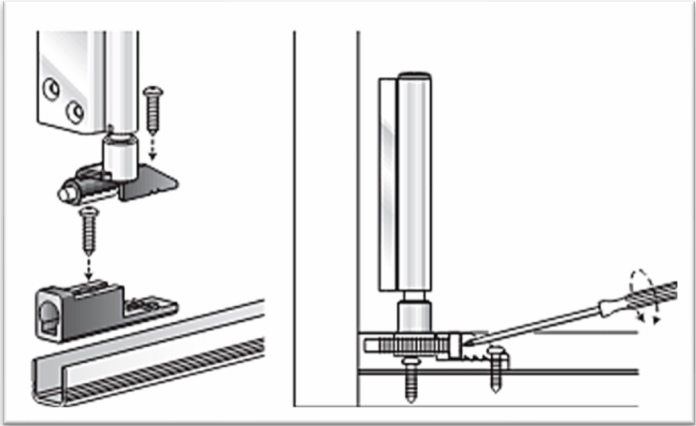

Fitting Pivot Panel

Adjust first panel to ensure it is plumb, level, and square (refer to Section below for guidance)

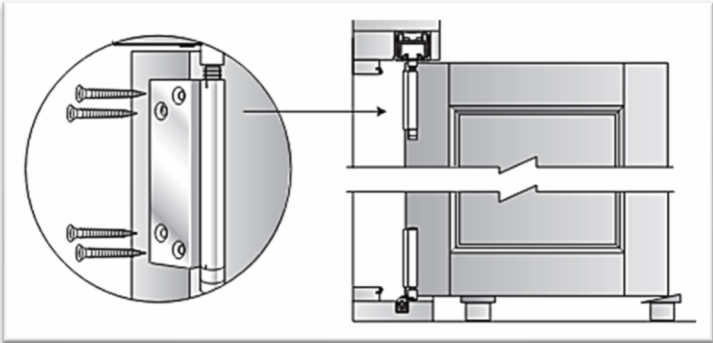

Adding Panels

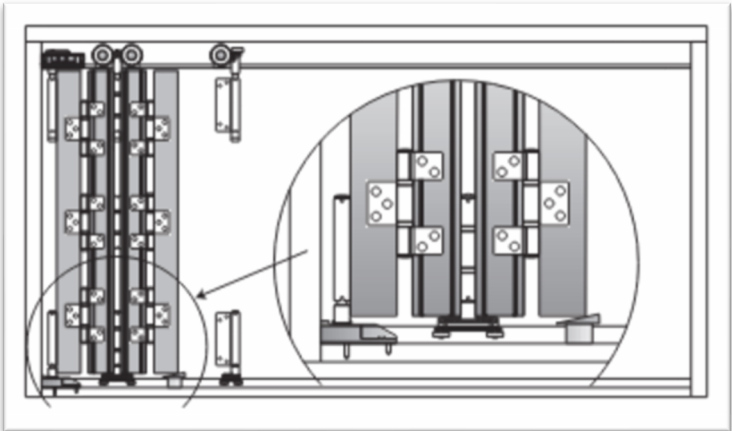

12.5 Plumb, Level & Square Assessment and Adjustment

IMPORTANT: Review Section 4.6 before reading the supplemental information below.

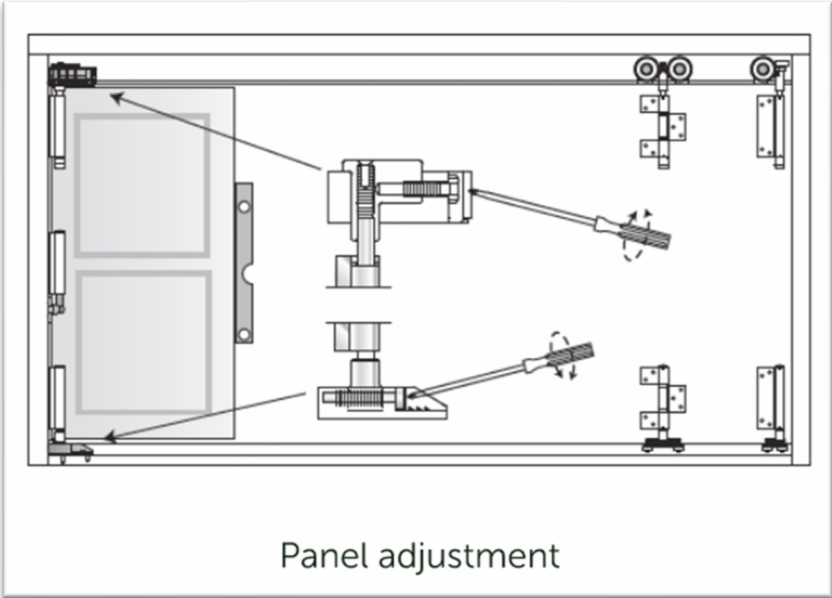

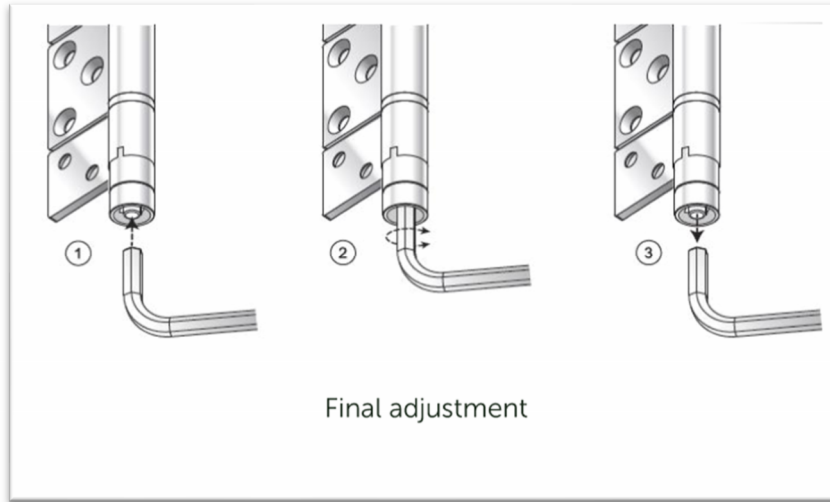

12.6 Lubrication

Refer to chapter 5 for guidance.



For more information watch this short video on VETTA's YouTube channel.

[How It Works - ELITE Outward Folding Door](#)

13 Supplemental: Tilt Turn Balcony Door (ELITE E92)

13.1 How To Operate

Ideal for balconies, terraces, side utility doors, or any location that does not require an exterior lockset, all Elite-series window frames can be adapted to the 'win-door' style by replacing the wooden window threshold with a barrier-free aluminum threshold. This door retains the tilt-and-turn functionality of a tilt-and-turn window and is operated and locked exclusively from the interior.

Tilt & Turn Door

Closed (1)

Opens Side Turn Function (2)

Opens Top Micro Tilt Vent Function (3)

Opens Top Tilt Function (4)

Turn Only Door

Closed (1)

Open Side Turn Function (2)

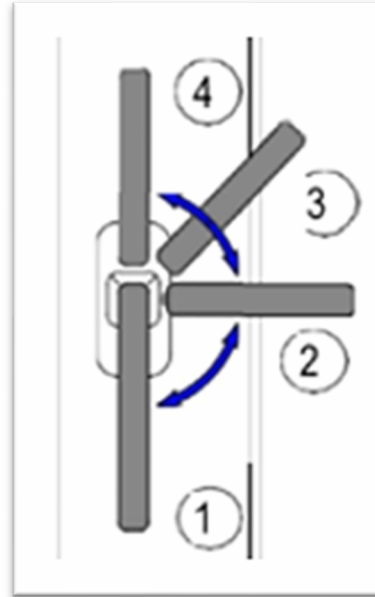

Fixing Common Operation Errors

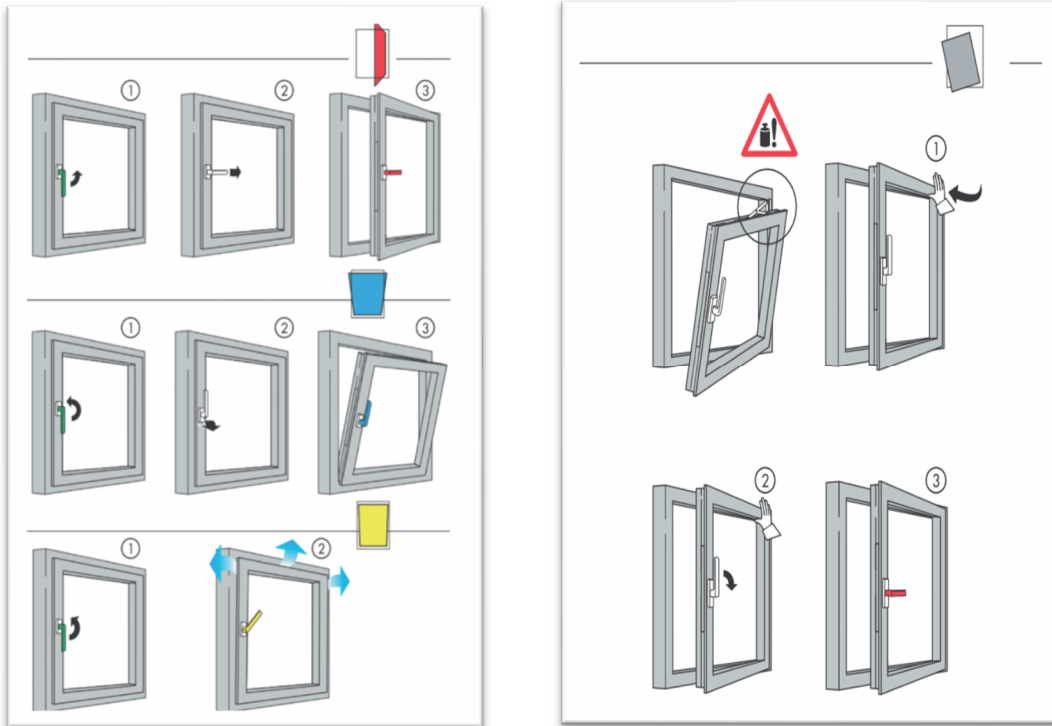

13.2 Design Considerations

Placement and Rough Opening

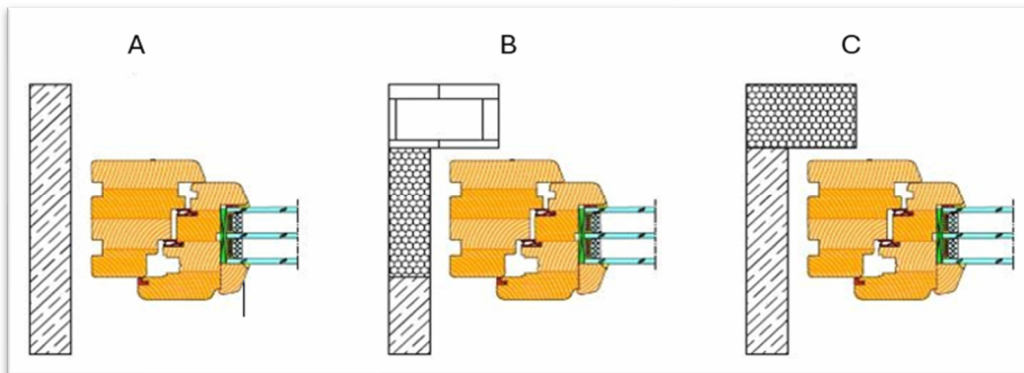

A.in single - layer wall - in the middle of the wall thickness

B.in sandwich wall with internal thermal insulation - in the thermal insulation area

C.in a wall with external insulation - aligned to the external reveal.

Sealing balcony doors with low aluminum threshold

1. Neutral Cure Silicone
2. Vapour tight insulation tape

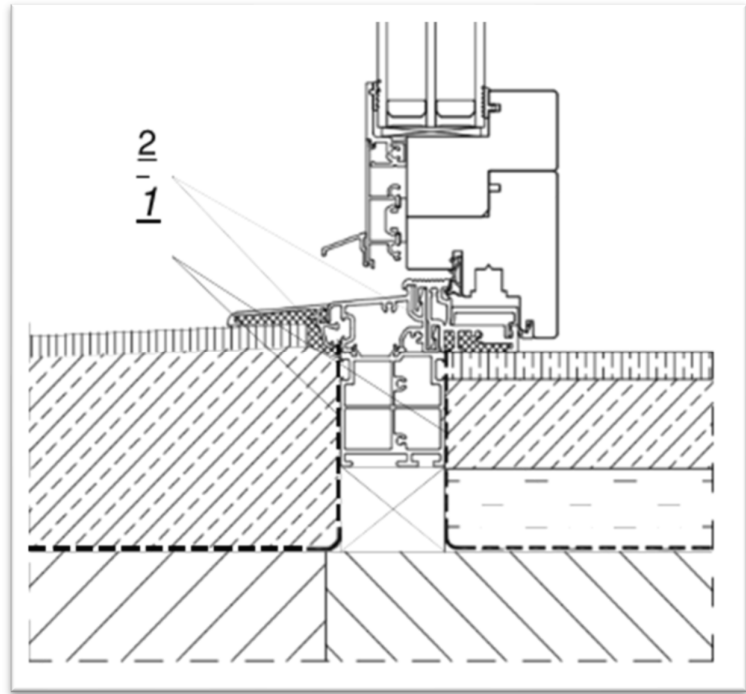

13.3 Operable Sash Removal & Install

IMPORTANT: Review Chapter 4 and Chapter 5 before reading the additional supplemental information below.

13.4 Adjustment

IMPORTANT: Review Chapter 5 before reading the supplemental information below.

Tools required:

- Spanner/Allen key (11mm bolt and 4mm Allen) provided with your order.



Legend

(A) Stay and top hinge

Regulates angle of sash

(B) Locking cams

*Regulates pressure on frame and
adjusts ease of handle operation*

(C) Tilt sash hinge

(D) Bottom hinge

regulates height of sash

(E) Door snapper

not applicable for windows

(F) Sash lift (no adjustment)

(G) Run-up (no adjustment)

(H) Load transfer

*For windows with hidden hinges to
adjust height and load of sash*

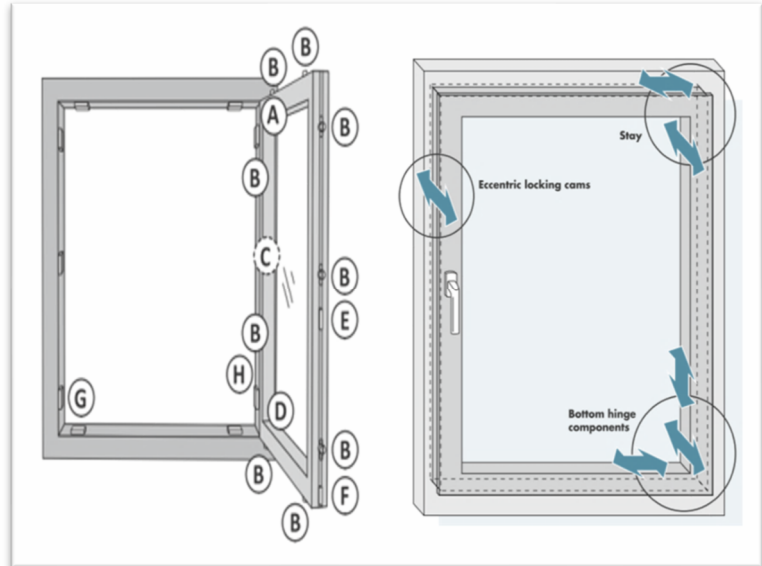

Standard Hinge on Stay – (A) on Legend. Titan iP – Hinge side Titan/Si-line

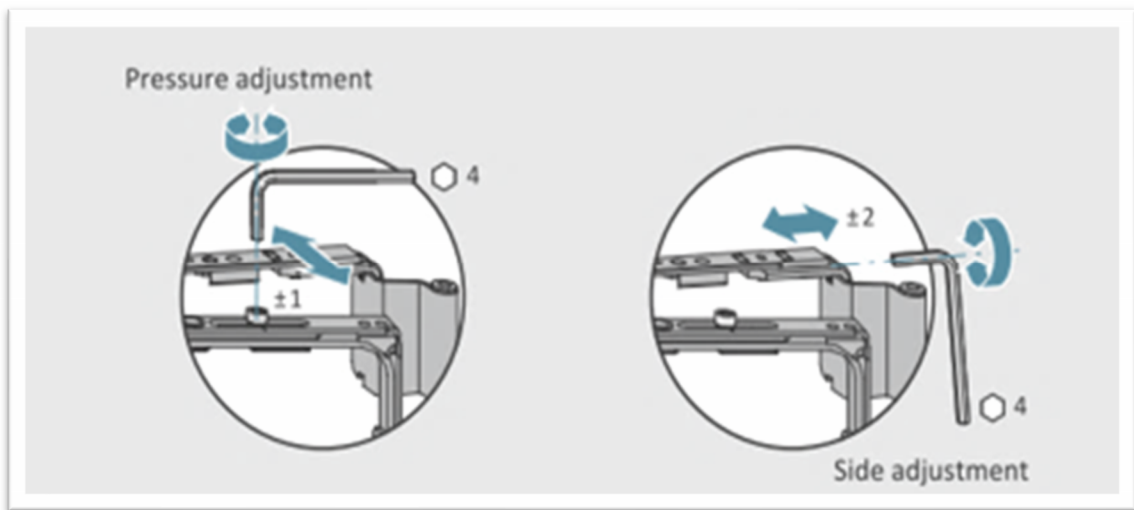

Locking Cam - (B) on Previous Page Legend
Titan
iP-AF comfort mushrooms

Bottom Frame Hinge - (D) on Previous Page Legend

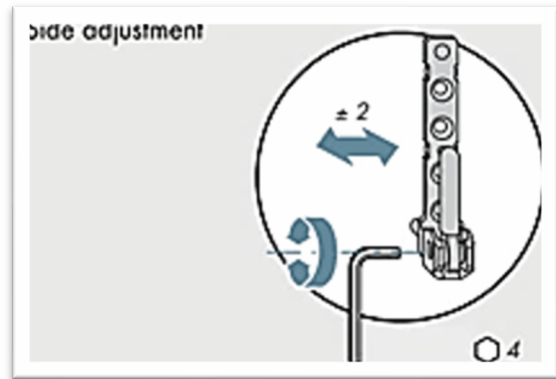
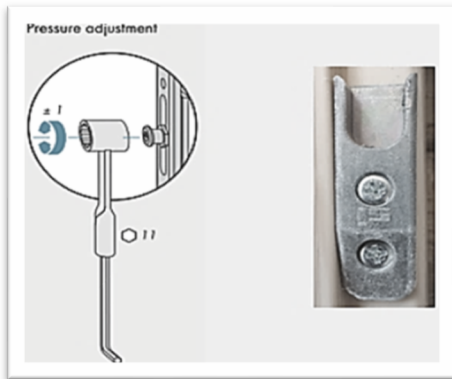

Bottom Sash Hinge - (D) on Previous Page Legend

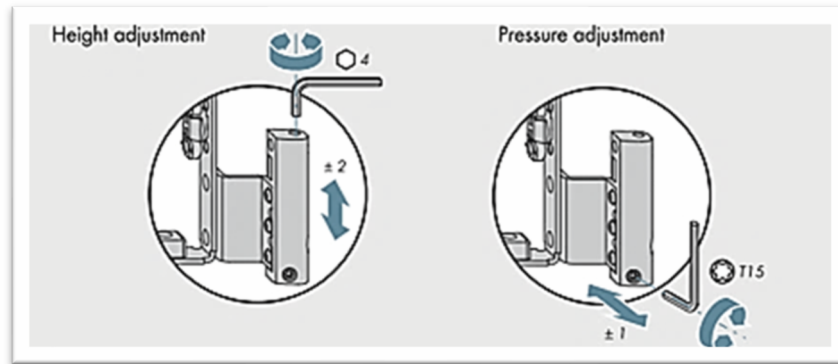

Balcony fastener adjustment (E) on Previous Page Legend

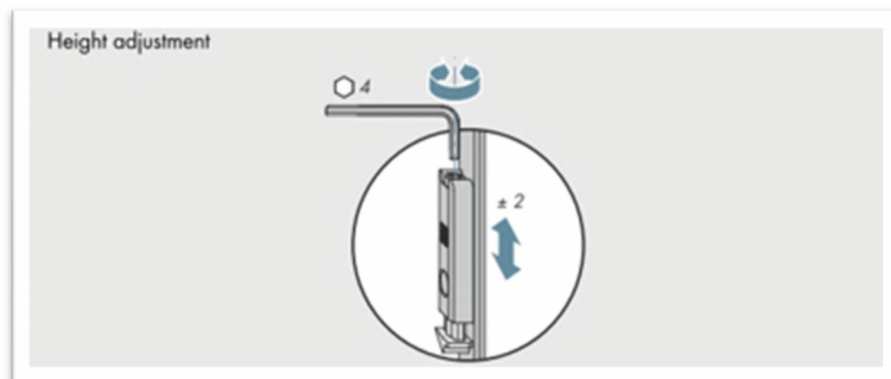

13.5 Lubrication

IMPORTANT: Review Section 4.7 before reading the supplemental information below.

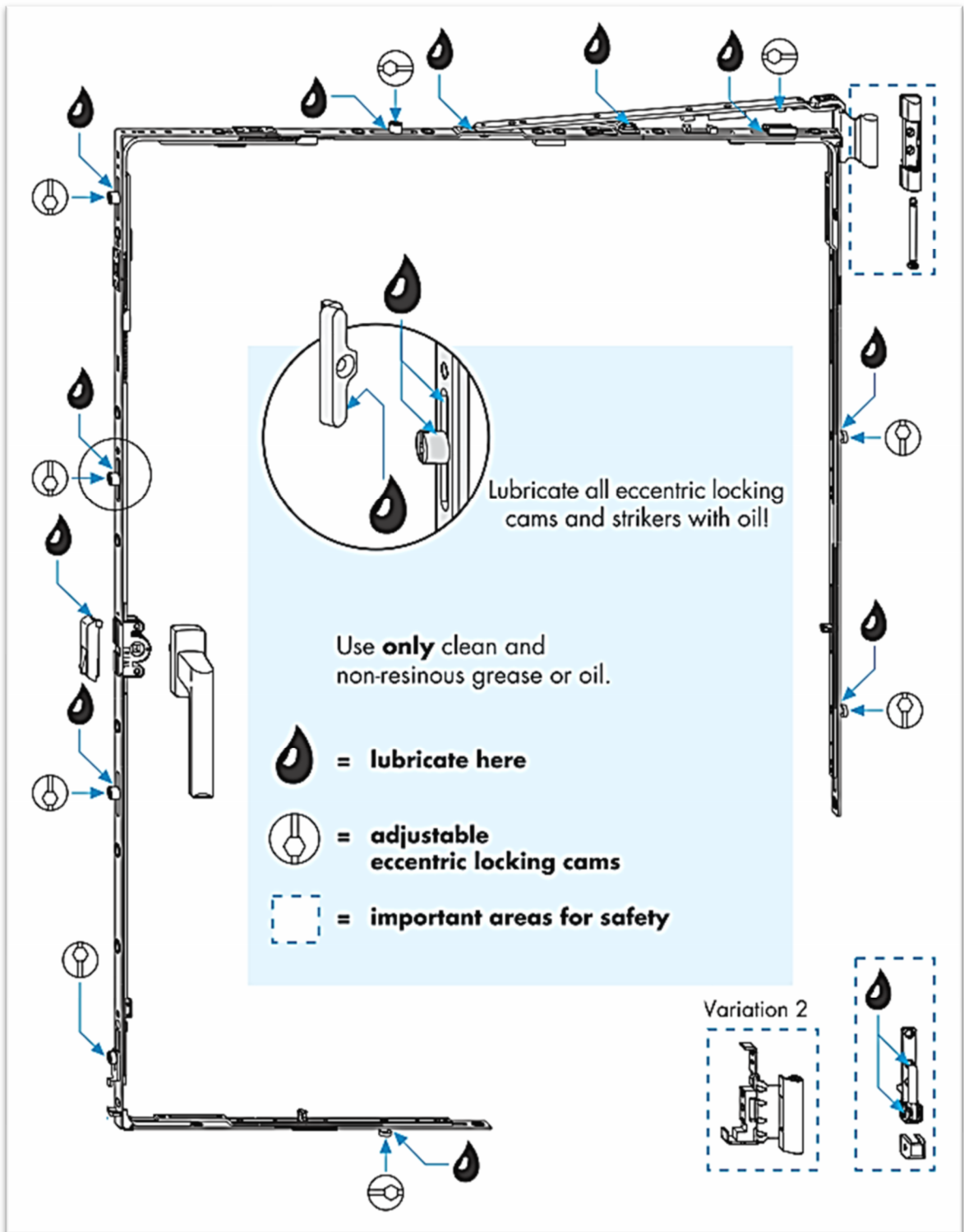

Stay - (A) on Previous Legend.

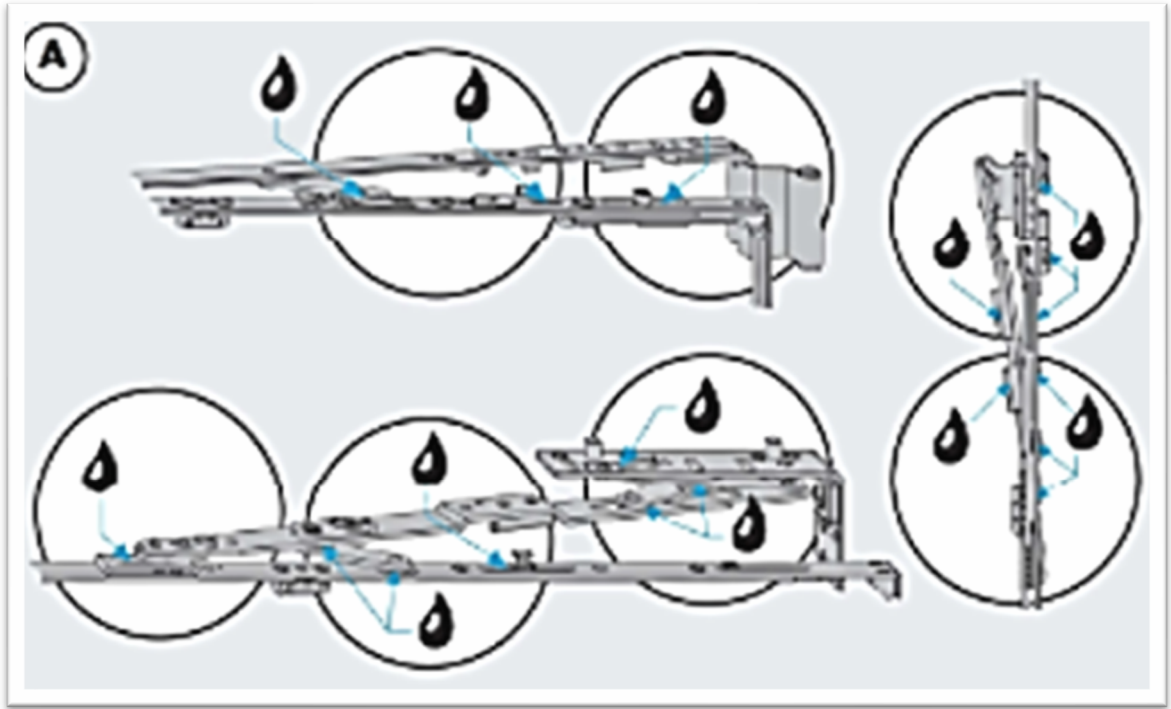

Catches - (C) on Previous Legend

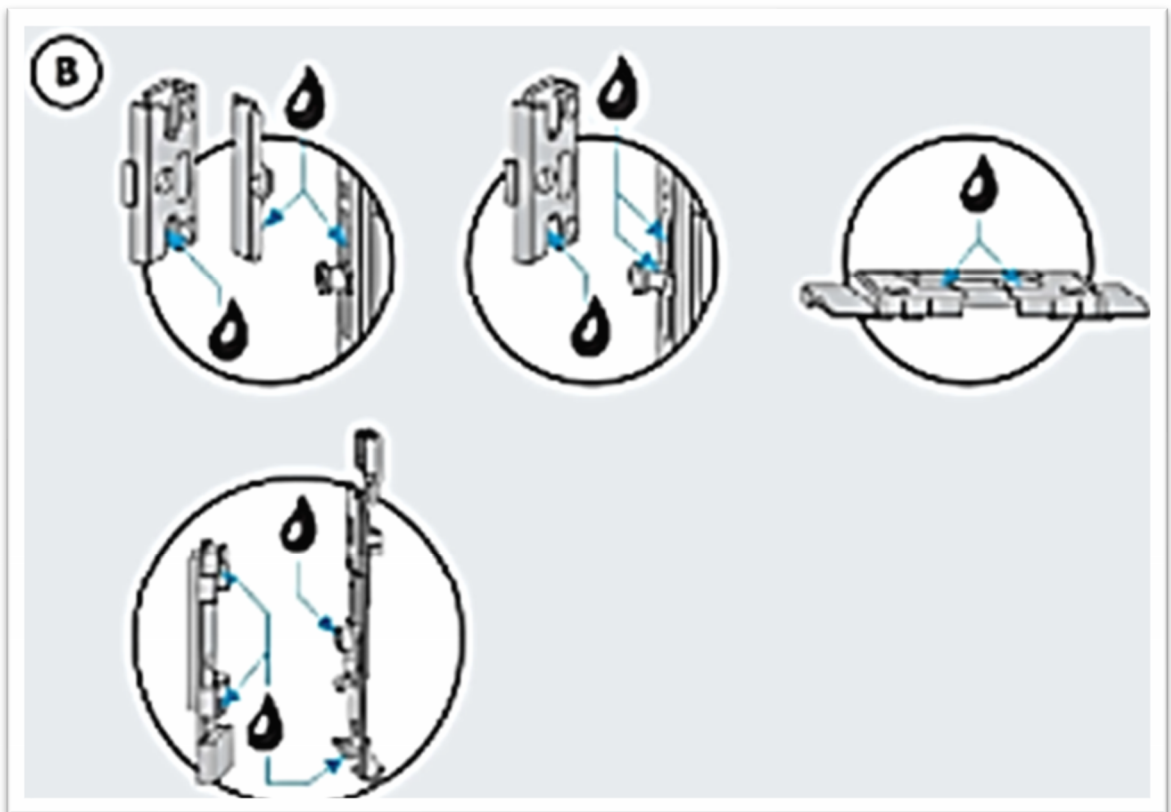

Hinges – (D) on Previous Legend

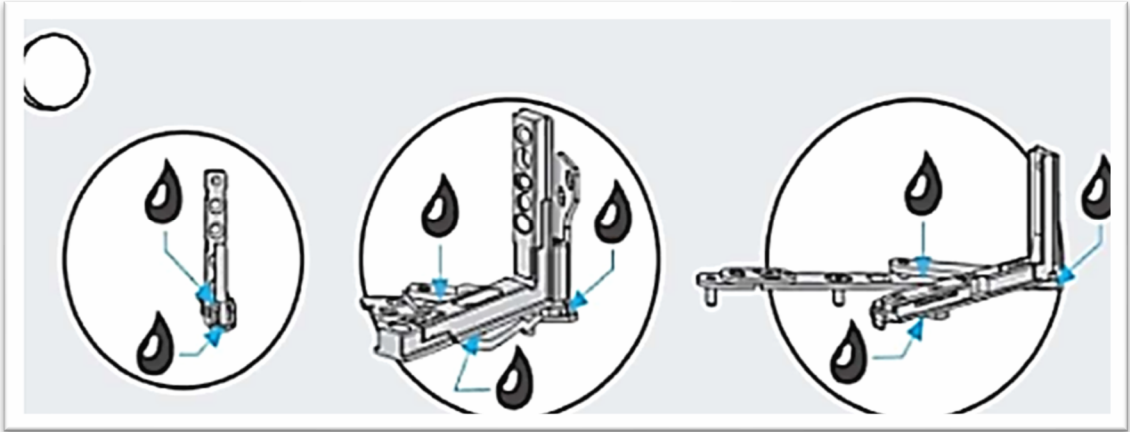

14 Supplemental: Side Hinge Entry/Balcony Door, Manual Lock (OPTIMA, Euro-Alu)

14.1 How To Operate

There are two multipoint locking deadbolt options.



Assa Abloy

1. Extension Hook & Sealing element
2. Latch
3. Deadbolt
4. Sash Face Plate

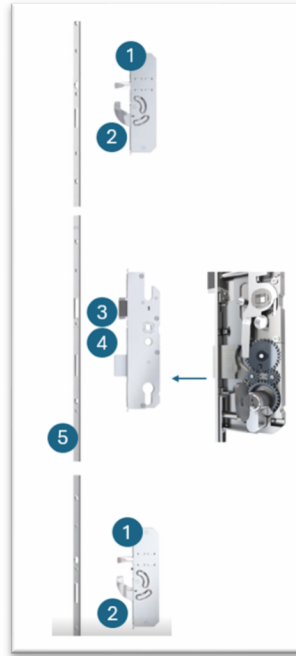

Siegenia KRV AS 3600

1. Extension Hook
2. Sealing element
3. Latch
4. Deadbolt
5. Sash Face Plate

Both doors are manually operated using the handle. In the horizontal position, the door is closed. Raising the handle engages the top and bottom extension hooks, while lowering it disengages them. The deadbolt is manually operated for added security using an interior thumb-turn located below the handle.

From the exterior, the handle must be raised to engage the extension hooks before turning the key to lock. To unlock, the key must be turned first, then the handle lowered to release the hooks. Manually engaging the extension hooks ensures that even if the hinges were removed in an attempted break-in, the door remains securely locked.

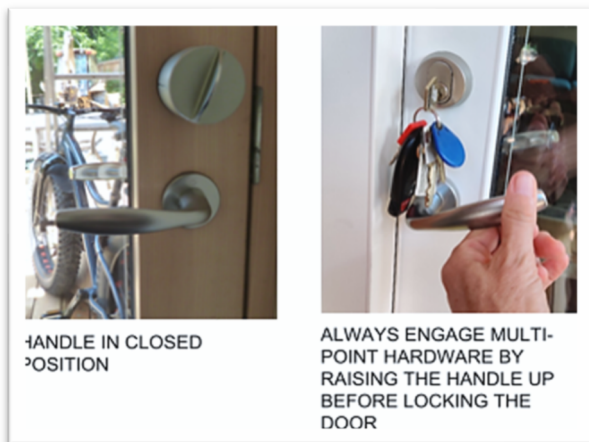
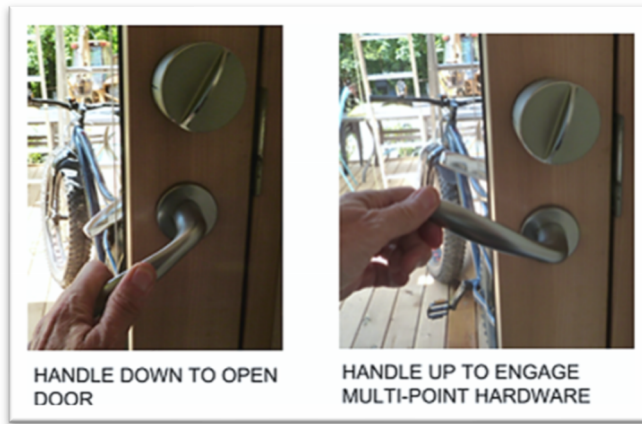

The image on the left shows the handle model for the Assa Abloy locking assembly. The handle model for the Siegenia KRV, shown on the right, functions the same way but includes a backplate that houses both the handle and the locking cylinder with the thumb turn.

AS 3600 Basic functions

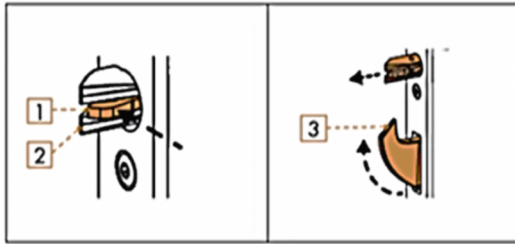

Automatic locking mechanism:

- ▶ Shut the door.
- The triggers [1] of the falling bolt [2] are pressed inwards on contact with the frame part. Falling bolt and hook bolt [3] move automatically to the locking position.
- The main lock latch engages in the frame part.

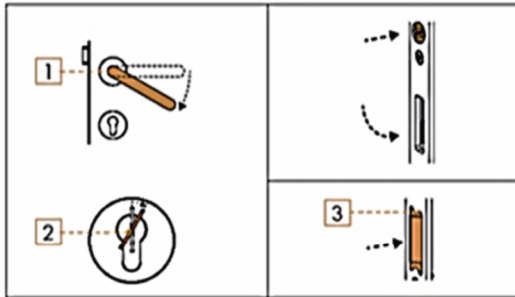

Open:

- ▶ Activate the lever handle [1] or turn the key [2] in the direction of release.
- The falling bolt, hook bolt and main lock latch [3] retract when the lever handle is activated or when the key is turned to the release position.

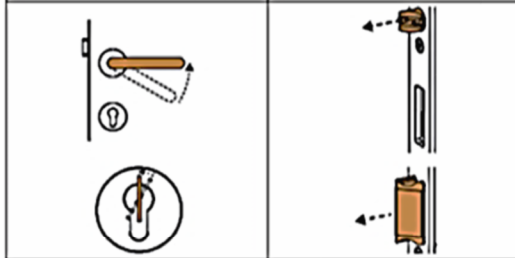

- ▶ Release the lever handle or turn the key to the withdrawal position.
- The falling bolts move to the trigger position.
- The hook bolts remain in the release position.
- The main lock latch extends.

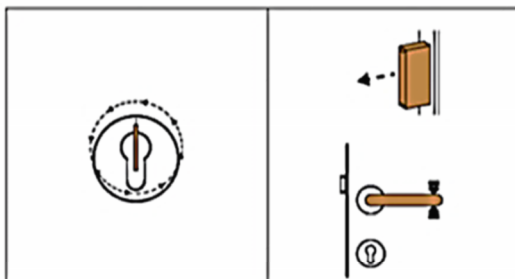

Activating the child-proof lock:

- ▶ Turn the key once in the locking direction.
- The main lock bolt extends.
- The lever handle is blocked when the main lock bolt is in the locking position. The door cannot be opened without a key.

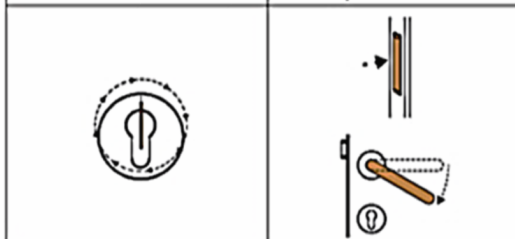

- ▶ Turn the key once in the release direction.
- The main lock bolt retracts.
- The lever handle is released when the main lock bolt is in the release position.

14.2 Design Considerations

Placement and Rough Opening

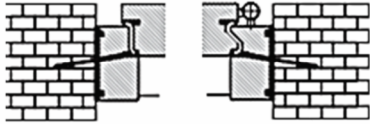
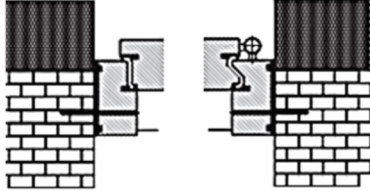
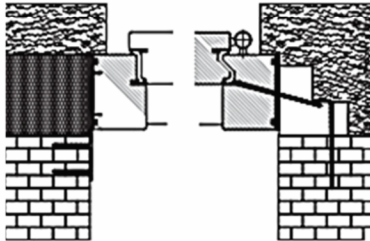
Installation technique	
<p>1 With wall plugs screwed under the gasket and/or under the catch plates of the lock</p> 	<p>Recommended for doors without transoms</p> <p>In the frame rebates (after removing the gasket), make mounting holes for screws or dowels by drilling at least 3 holes in each stile (the first one at the distance of 10 cm from the header and 2-3 proportionally on the remaining height of the frame). In the case of two-leaf doors, additionally use 1 screw (dowel) to fix the header in the middle of its length. Enlarge the holes for the screw heads. After the screws have been screwed in, the holes are masked by the reinstalled gasket.</p>
<p>2 With wall plugs screwed into the door frame and plugged with a plastic plug in the same color as the door</p> 	<p>Acceptable for doors without transoms</p> <p>Make holes in the stiles through the entire thickness of the frame (see the figure to the left); their number and height should be the same as described above. Enlarge the holes for the screw (dowel) heads. Mask the heads of the screws with plugs of appropriate colors using an adhesive.</p>
<p>3 .A) With sheet metal. B) With a load-bearing frame</p> 	<p>Acceptable in doors without transoms, recommended for doors with transoms</p> <p>Bend 6-7 pcs of carpentry metal sheets (min. 1 mm thick, min. 80 mm wide) to accommodate the clearance between the wall and the frame. In the dowel areas mentioned above, fasten the sheets to the frame with at least 3 screws dia. 3.5 x 30. In the case of 2-leaf doors, use an additional sheet in the header. Fix the sheets or frames to the wall with dowels or mounting screws. In option B), the frame can be fixed in the gasket groove or through the whole thickness of the stile.</p>

Place in the wall

A Solid wall

In a solid wall, the door should be installed at a mid-point of the wall thickness.

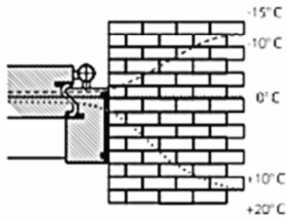

B Insulated wall

In an insulated wall, the door should be installed as close as possible to the outside plane of the load-bearing wall.

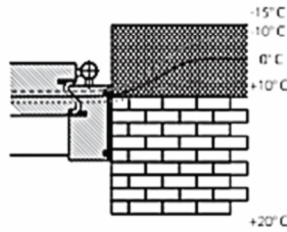

C Cavity wall

In a cavity wall, the door should be placed in the plane of the insulation. It should be possible to adjust the hinges by thickening the stiles of the frame.

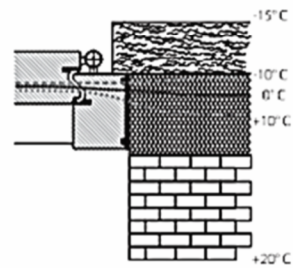

If there is no installation channel, it must be cut out and its bottom must be leveled.

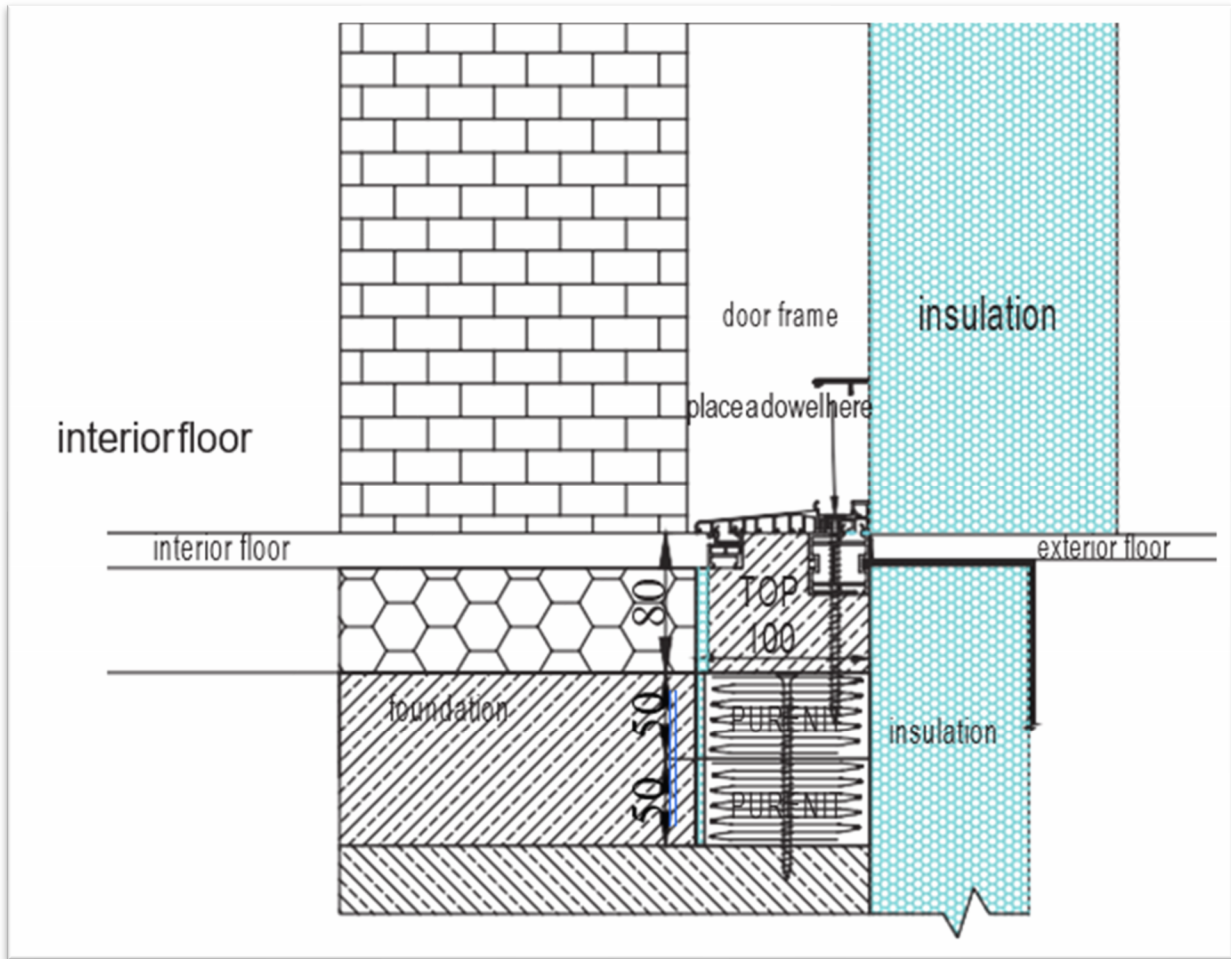

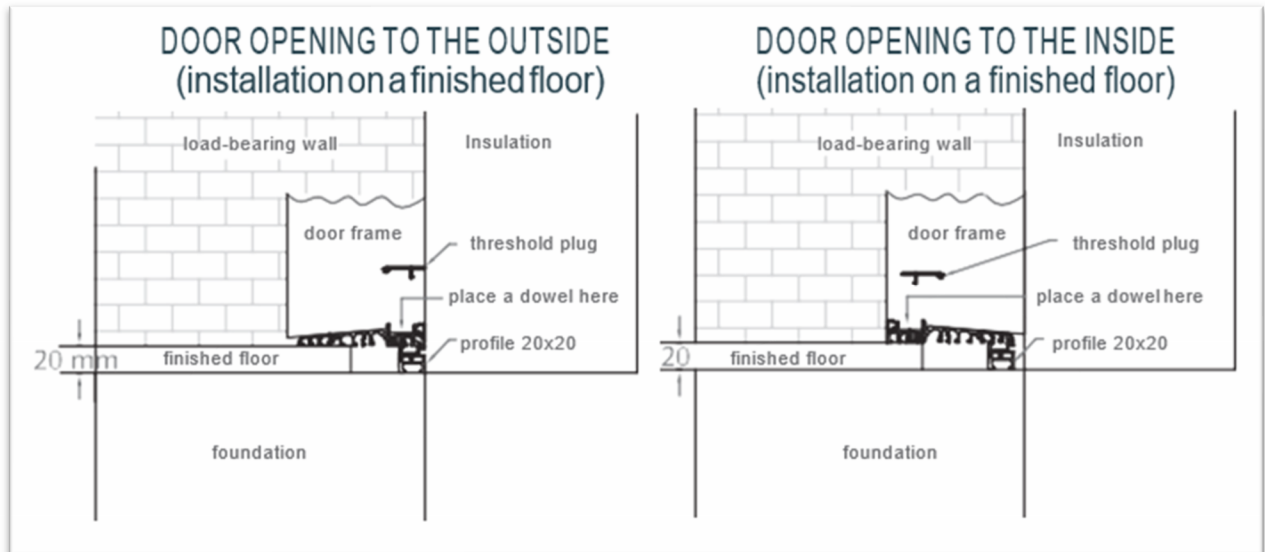

14.3 Operable Sash Removal & Install

Open the sash using a Torx 20. Loosen the six screws (shown with Letter A).

Next, using the 3mm Allen key.

Rotate the set screw (shown with letter B).

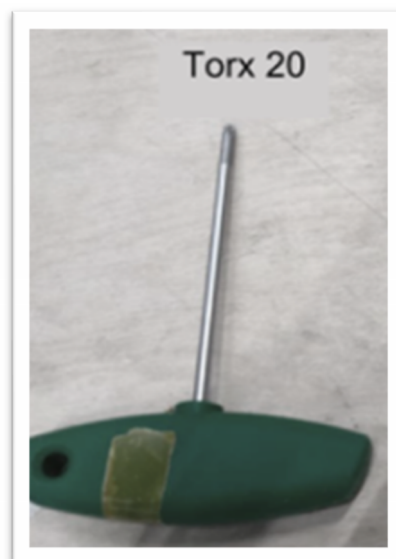

Removing/Installing the Handle

Insert installation Allen key (it comes in the box with the handles) into the small hole on the underside of the handle. Gently pull the key towards you.

Pull both handles out to remove.



14.4 Combining Sets

IMPORTANT: Review chapter 5

14.5 Adjustment

IMPORTANT: Review chapter 5 before reading the supplemental information below.

Tools required:

- Allen Key 6mm
- Allen Key 3mm
- Torx 20

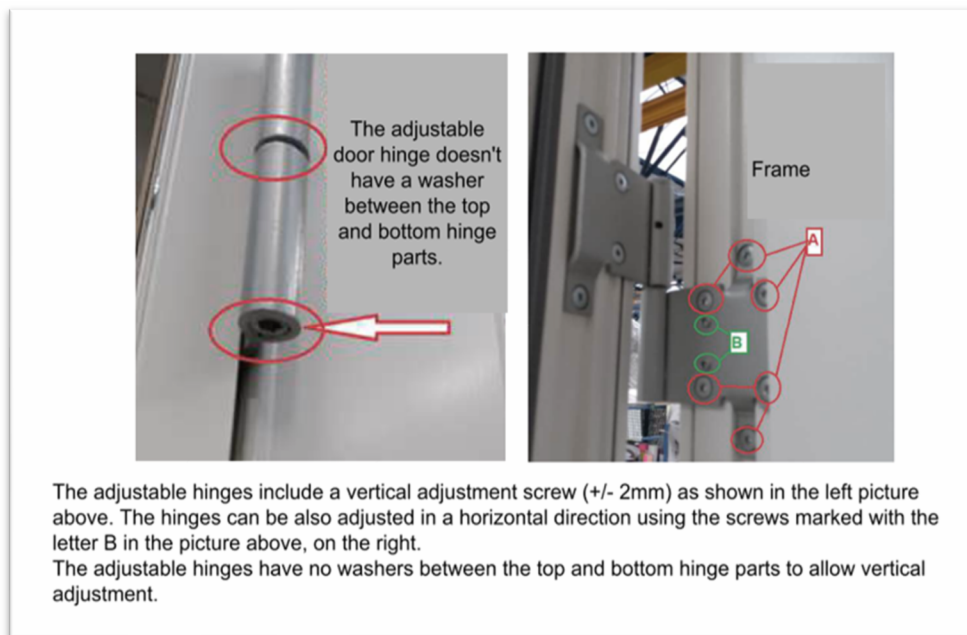

Vertical Adjustment

Use the 6mm Allen key to adjust the hinges in a vertical direction.

The adjustment range is $\pm 2\text{mm}$.

Once the desired height is achieved, the adjustment screws on all hinges should be tightened to make sure that all hinges work evenly.



Horizontal Adjustment

Ensure adjustments are done evenly on all hinges incrementally so the door is not twisted. Using a Torx 20 screwdriver, loosen slightly screws shown with Letter A. Adjust horizontal direction using screws shown with Letter B. Finish by re-tightening screws shown with Letter A.

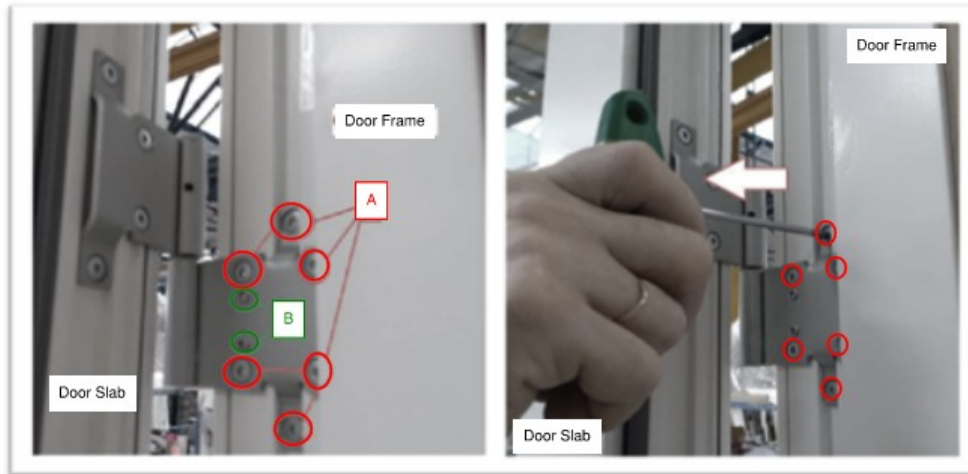

Transport Cap and Adjustment for Door with Siegenia KRV locking assembly.

- Frame Side – Remove and discard the transport support cap shown in solid orange below.
- Ensure a 2mm to 5mm gap between the sash and frame side locking assembly to allow the hardware to properly activate and connect.

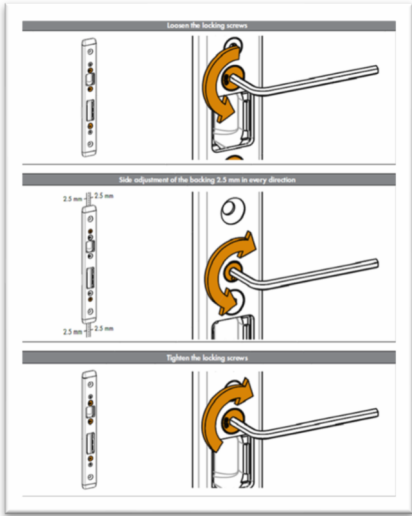
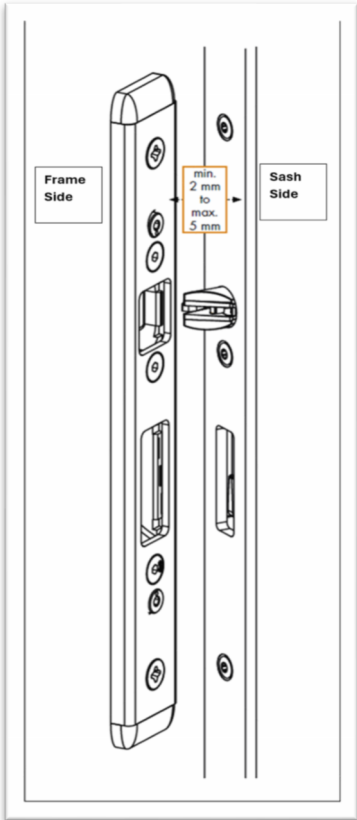

14.6 Lubrication

IMPORTANT: Review chapter 5 before reading the supplemental information below.

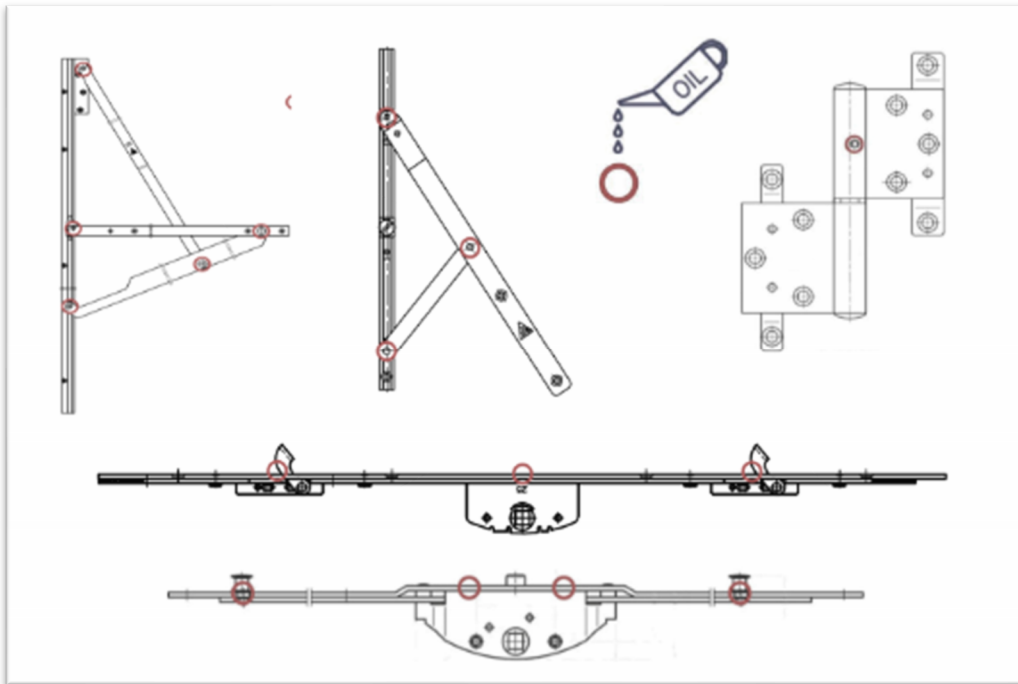

For more information watch this short video on VETTA's YouTube channel.

[How To – Remove HOPPE Quick Fit Door Handle Set](#)

[How It Works - OPTIMA Door](#)

[How it Works - Entry Door Danalock with Danapad](#)

15 Supplemental: Side Hinge Entry & Balcony Doors, Auto Lock (CAL)

15.1 How To Operate

The door is available with either interior and exterior handles, or an interior handle paired with an exterior pull tab or pull bar.

In the horizontal position, the handle is closed. To open from the interior, turn the handle downward. To close, return it to the horizontal position.

From the exterior, unlock the door using a key or keyless device (keypad, fob, or fingerprint reader), then turn the handle downward and push, or simply push the pull bar.

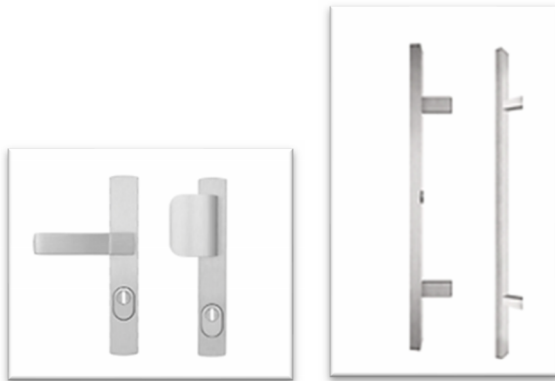

The magnetic trigger automatically activates a pin when the door is fully closed, releasing the hooks to securely lock. For added security, the deadbolt is manually operated by an interior thumb-turn.

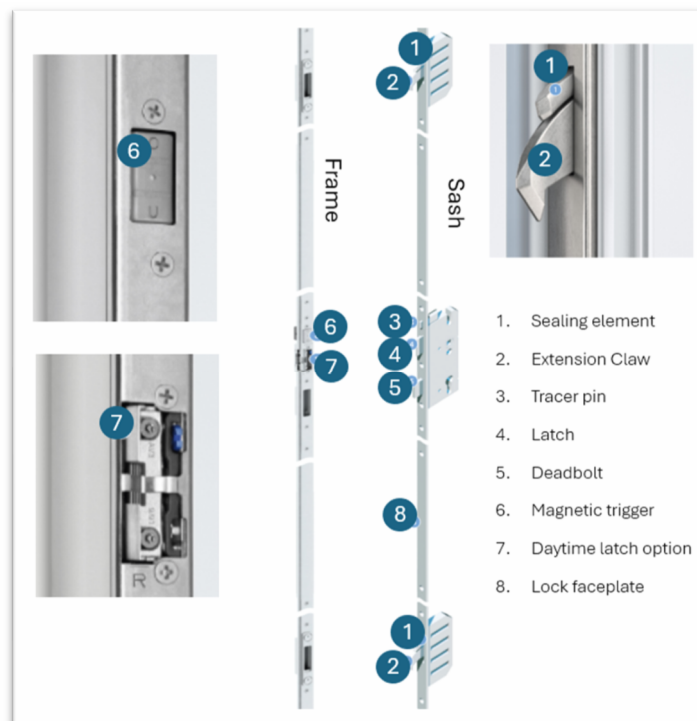

Below, the left image shows the sealing and extension hooks in their retracted position when the door is open. The middle and right images illustrate the activation process and final engagement within the hardware keeps.



The optional daytime latch, when activated by pushing the blue tab down into the active position, overrides the magnetic trigger, preventing the door from locking and allowing it to be opened from the outside with a gentle push. To reactivate the magnetic trigger, simply push the blue tab down again.

15.2 Design Considerations

Placement and Rough Opening

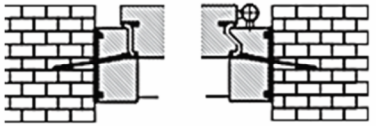
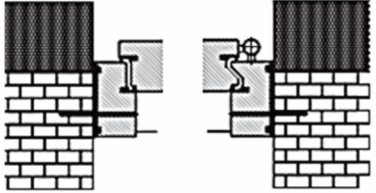
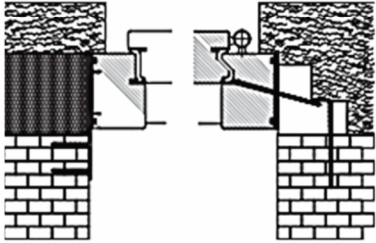
Installation technique	Recommended for doors without transoms
<p>1 With wall plugs screwed under the gasket and/or under the catch plates of the lock</p> 	<p>In the frame rebates (after removing the gasket), make mounting holes for screws or dowels by drilling at least 3 holes in each stile (the first one at the distance of 10 cm from the header and 2-3 proportionally on the remaining height of the frame). In the case of two-leaf doors, additionally use 1 screw (dowel) to fix the header in the middle of its length. Enlarge the holes for the screw heads. After the screws have been screwed in, the holes are masked by the reinstalled gasket.</p>
<p>2 With wall plugs screwed into the door frame and plugged with a plastic plug in the same color as the door</p> 	<p>Acceptable for doors without transoms</p> <p>Make holes in the stiles through the entire thickness of the frame (see the figure to the left); their number and height should be the same as described above. Enlarge the holes for the screw (dowel) heads. Mask the heads of the screws with plugs of appropriate colors using an adhesive.</p>
<p>3 .A) With sheet metal. B) With a load-bearing frame</p> 	<p>Acceptable in doors without transoms, recommended for doors with transoms</p> <p>Bend 6-7 pcs of carpentry metal sheets (min. 1 mm thick, min. 80 mm wide) to accommodate the clearance between the wall and the frame. In the dowel areas mentioned above, fasten the sheets to the frame with at least 3 screws dia. 3.5 x 30. In the case of 2-leaf doors, use an additional sheet in the header. Fix the sheets or frames to the wall with dowels or mounting screws. In option B), the frame can be fixed in the gasket groove or through the whole thickness of the stile.</p>

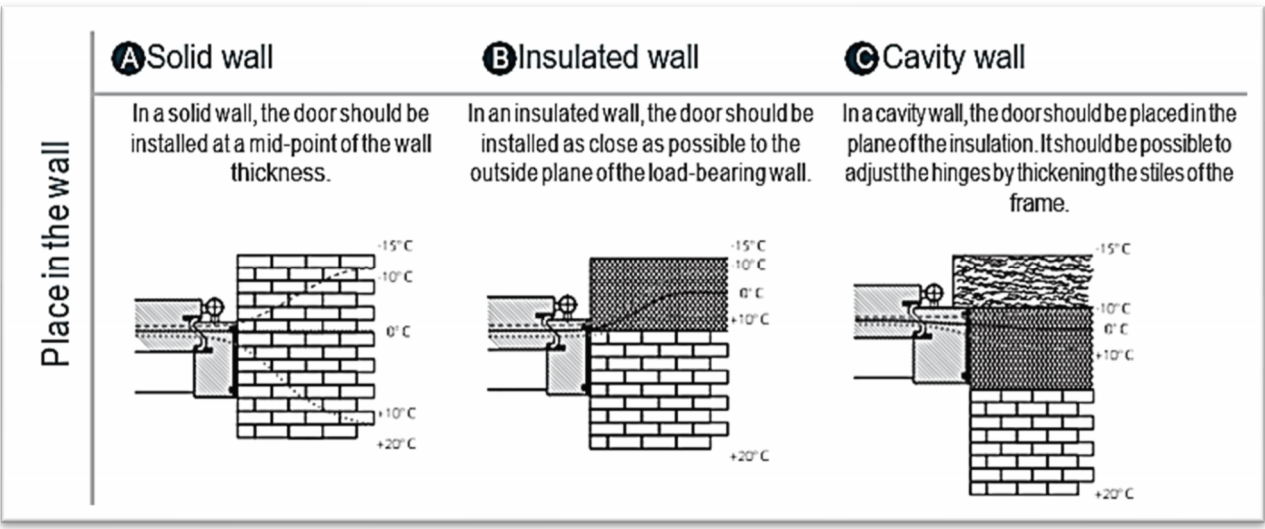

If there is no installation channel, it must be cut out and its bottom must be leveled.

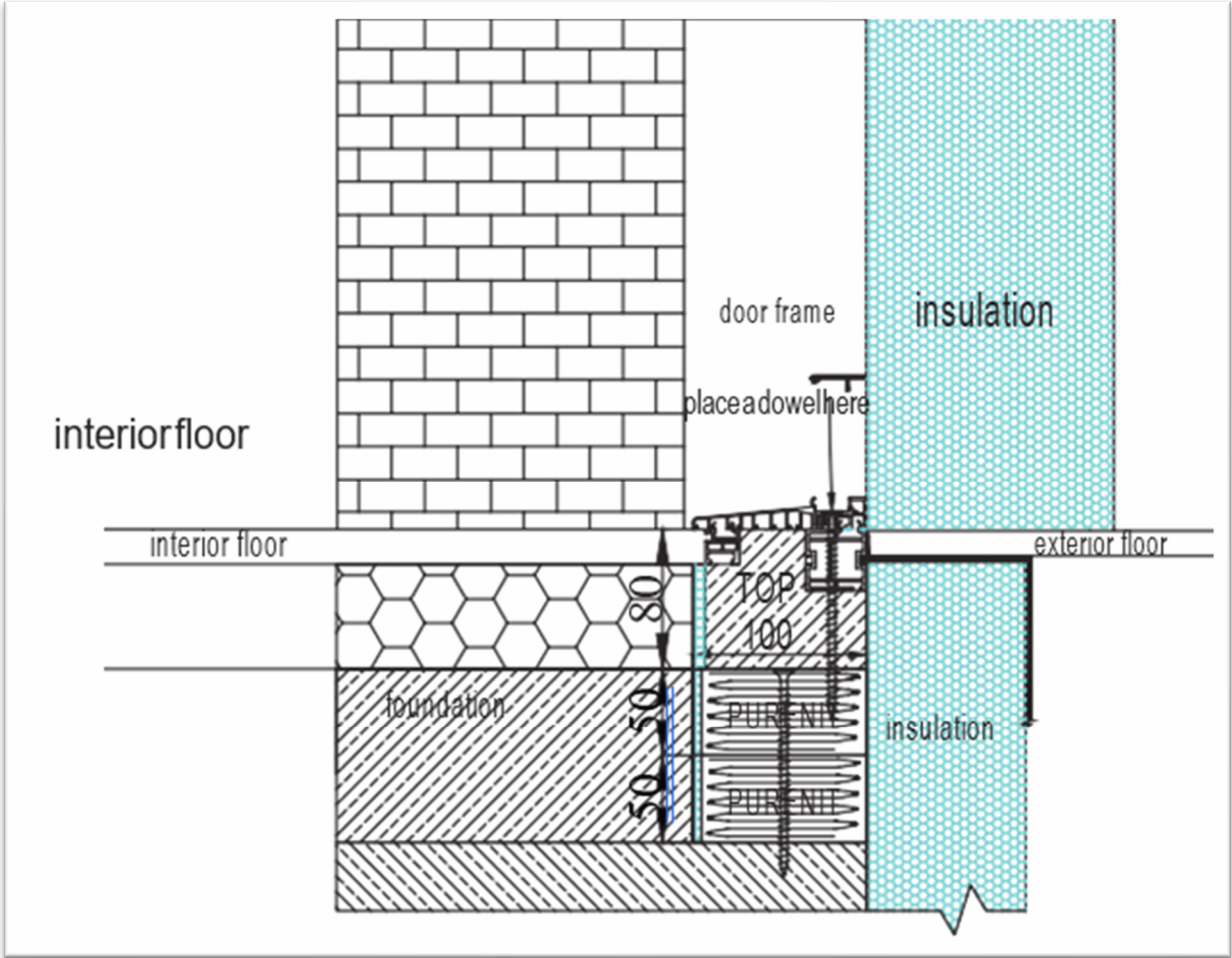

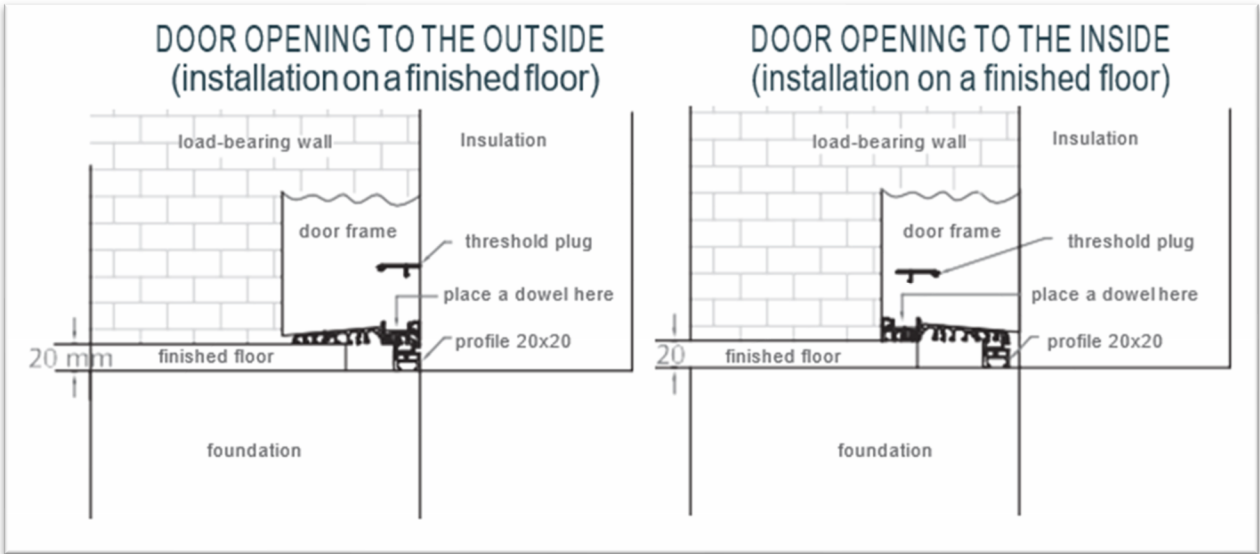

Sealing balcony doors with low aluminum threshold

- 1. Neutral Cure Silicone
- 2. Vapour tight insulation tape

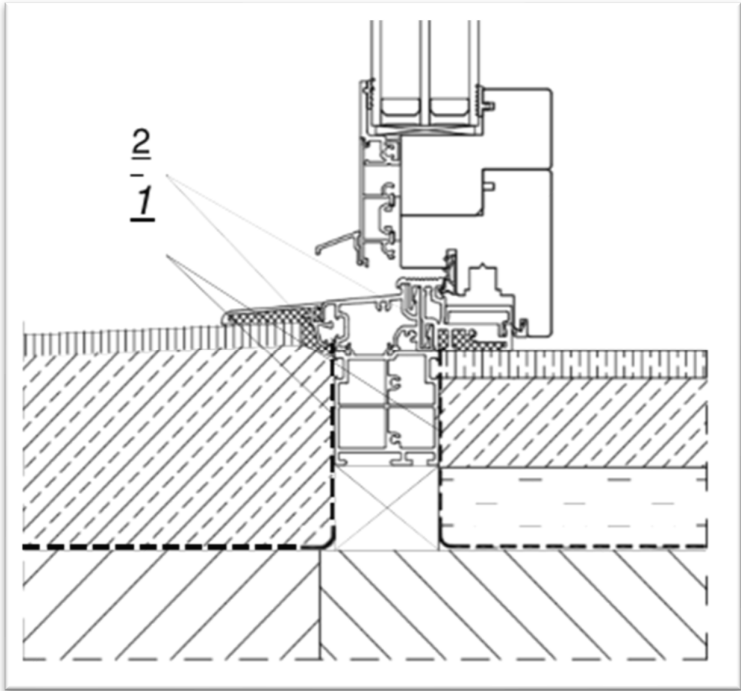

15.3 Operable Sash Removal & Install

Secure door threshold in-place.

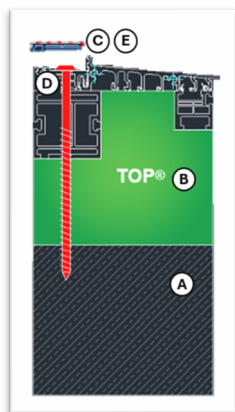

Example: CAL Door

Build a solid and level foundation.

Install the thermal sub-sill protection.

Carefully remove upper threshold cover using a wooden or plastic wedge tool.

Fix the threshold to a solid and leveled foundation using three or more screws – depending on the installation situation.

Reattach cover.



15.4 Sash Removal and Install

Step 1: Remove Hinge Covers

Carefully remove hinge covers to expose the hinge bolts.

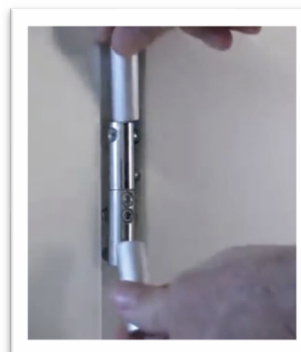

Step 2: Loosen and Remove Hinges

Using a 5mm Allen key, unscrew the bolts circled in blue in the diagram. Loosen each bolt gradually alternating between hinges, to prevent twisting the door.

Caution: These doors are heavy. Ensure that two people are present to safely support and catch the door as it comes free from the hinges.



Step 3: Reinstallation

To reinstall, follow the same process in reverse.

IMPORTANT: After reinstalling, always replace the hinge covers, as they provide essential protection for the hinges.

Handle installation diagrammatic.

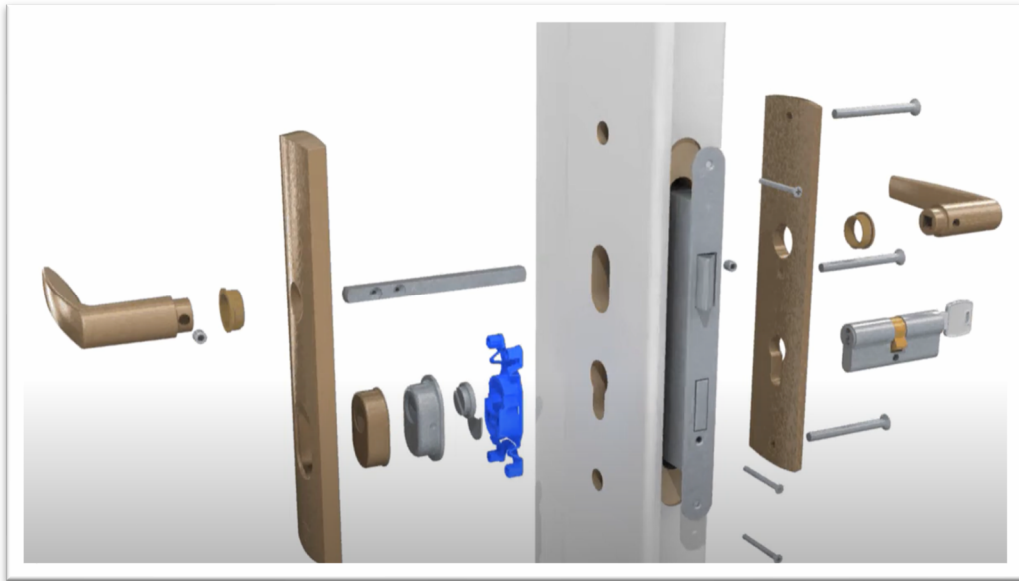

15.5 CAL Sidelight/Transom Assembly

IMPORTANT: Review Section 4.5 before reading the additional supplemental information below.

Materials Provided with Your Order

- Expansion tape, inside transom packaging. Store at temperatures above 5 degrees C for up to two months.
- Fixing screws
- Self drilling screws
- Mounting screws, in plastic bag glued to threshold.
- SFS MC2-S110 screws
- 4.5x50 screws

If any screws are lost, do not use other screws longer than 70mm as there is an extreme RISK OF DAMAGE TO TRANSOM GLAZING

Carpentry sheet metal and fastening screws (dowels) not supplied with product.

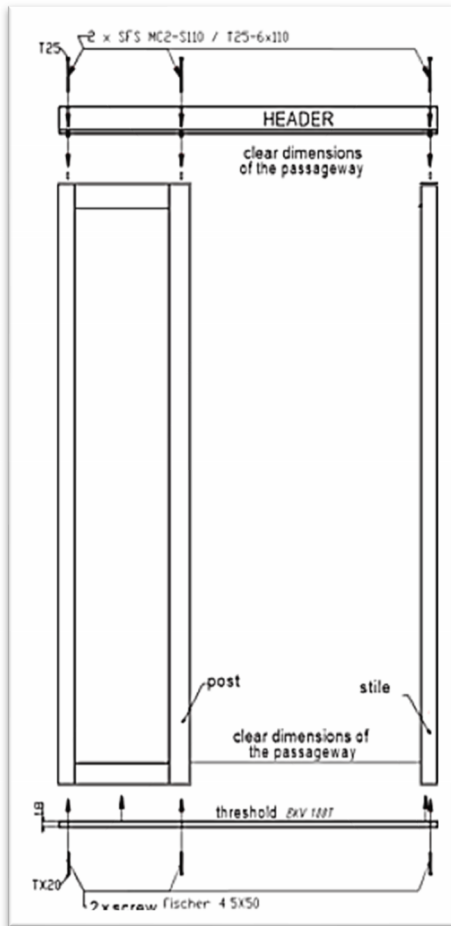

1. Press sleeves protruding from header into the holes in the vertical components.
2. Drive the SFS MC2-S110 screws through the holes in the header.
3. Place and fasten the threshold putting screws through the holes made previously with the screws 4.5x50mm
4. Inside the door opening, perform install in accordance with the door install rules.

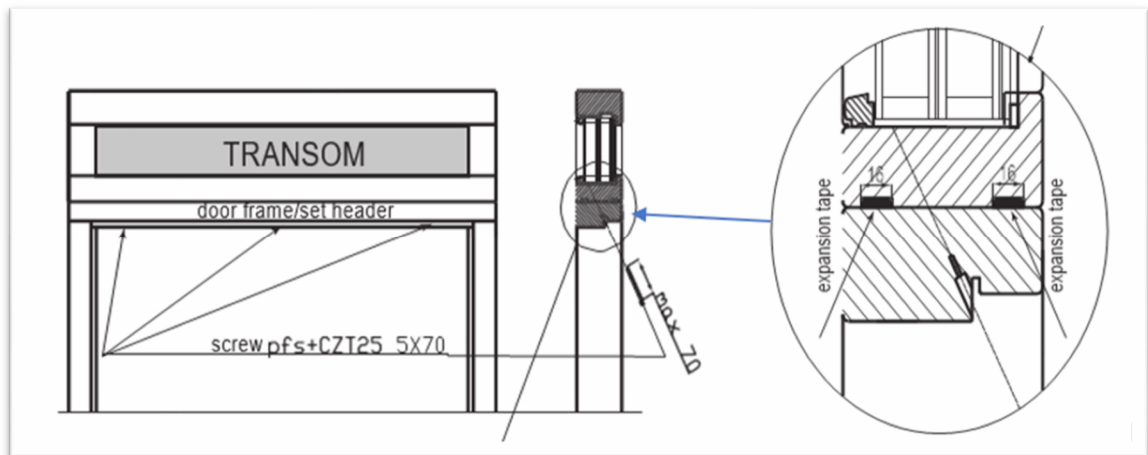

1. Remove gasket from header
2. In the 16x5mm grooves of the transom, place 15x4mm expansion tape
3. Place transom against header of door set
4. Screw five fixing screws into header gasket holes
5. Sets with side lights and transoms up to 500mm high can be additionally connected with self-

drilling screws on the wall side (2 pcs per side delivered with set)

6. Sets with side lights and transoms over 500mm high can be additionally joined with a minimum 200x100mm carpentry metal sheet fixed with wood screws on wall side.

15.6 Plumb, Level & Square Assessment and Adjustment

IMPORTANT: Review Section 4.6 before reading the supplemental information below.

For adjustments remove the hinge covers and use a 5 mm key to loosen/tighten bolts. Do not overtighten / loosen hinges as this could twist the sash or cause it to fall out of the frame.

- A. Remove hinge covers

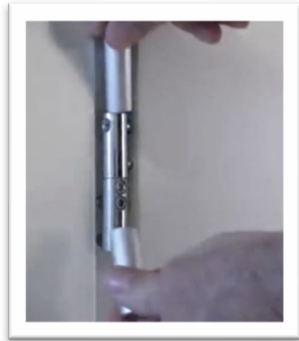

- B. Adjust pressure (depth) between door & frame

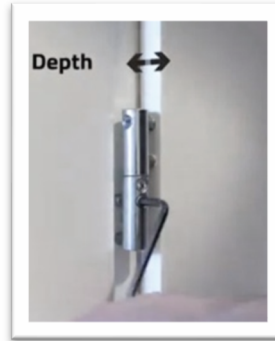

- C. Adjust height of door

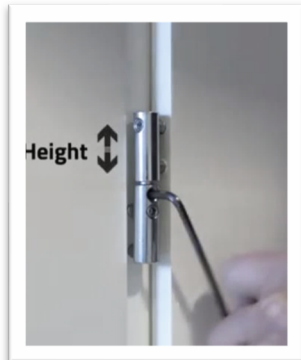

- D. Adjust side to side

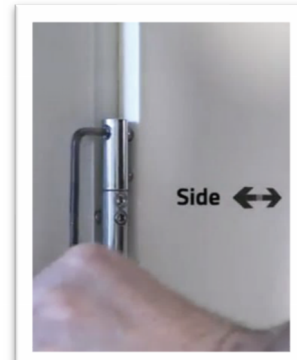

Check and adjust the door clearance to maintain a consistent 4mm (± 0.5 mm) air gap between the lock and the top of the keeps. Adjust the door closing pressure at the latch plate of the latch insert to ensure the gasket seals properly against the frame. Observe the contact pressure of the hinges, ensuring it is not too great, as excessive pressure can create a lever action on the entire unit. Reduce if necessary.

Visually check the alignment of the keeps. The center line of the lock faceplate should correspond with the line on the latch strike. Winkhaus pocket keeps should remain correctly positioned once fitted and should not require vertical adjustments.

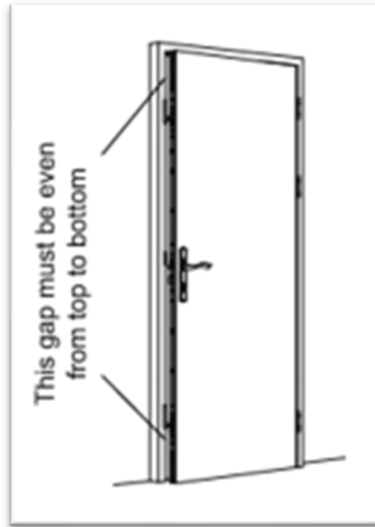

To verify hook keeps, throw the hooks with the door open and mark the tip of each thrown hook on the face of the door frame. The tip of each hook should be approximately 8mm below the aperture of the hook keep.

Ensure there is a 4mm gap between the lock faceplate and the compression adjustment plate. The sealing pressure of the sash against the frame is achieved through the latch only, while the hooks function as a security feature. Hooks should remain in "fresh air" without making direct contact within the keeps, as improper contact could hinder correct operation or damage the assembly.

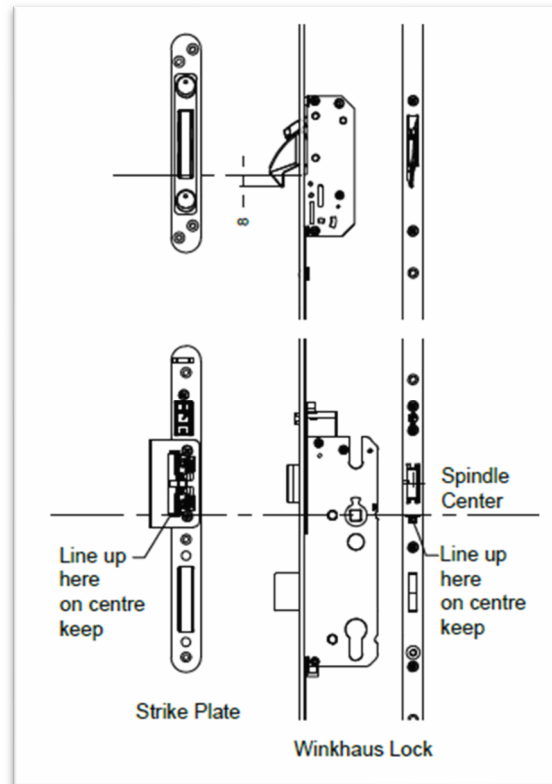
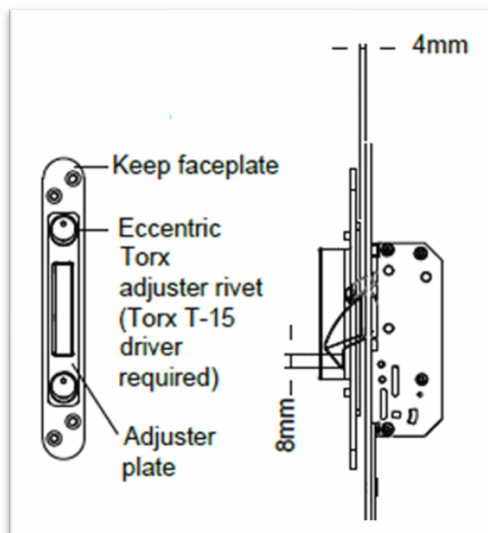

Main (middle) plate adjustment

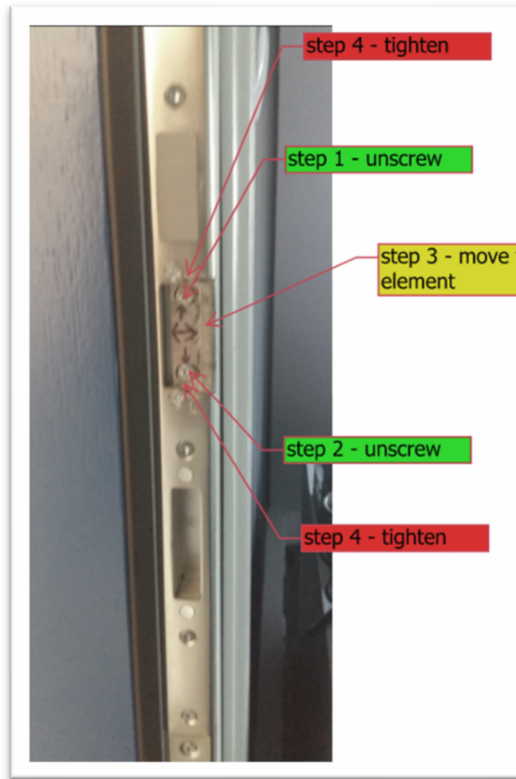

Upper and Lower Hook Adjustment

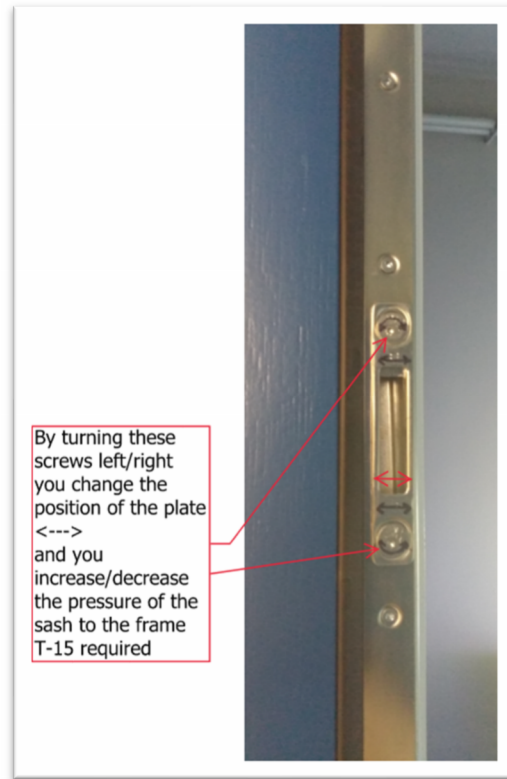

Locking Assembly Trouble Shooting Guide

Problem	Cause	Solution
Door closing difficulty	Dry latch	Apply lithium grease lubrication to latch, aperture and keep contact surface.
Stiff key operation	Door not latched correctly. (Test by holding hooks back with tape)	Relieve pressure on hooks by gently pulling door externally or pushing internally while operating the key
	Incorrectly adjusted keeps (latch is the compression point, the hook sides should not contact keeps)	Adjust centre keep accordingly
Unable to operate locking system (blocked)	Hooks fouling inside the keeps, door dropped, or incorrectly positioned keeps	Attempt to lift sash while operating the lock, then adjust back to alignment

Problem	Cause	Solution
	Excessive air gap to the lock side	Adjust sash closer to lock side
Door not latching	Lock drive strip fouling on routing.	Locate and relieve cause
	Misaligned center keep	Check centre lines
	Magnet stuck in	Check operation
	Day time latch switched on	Switch it off
Door not releasing	Latch keep movement impeded	Check and relieve
	Rebate clearance too tight	Adjust door rebate clearance
	Day time latch switch is off	Switch it on

PRESENTA CONCEALED HINGE

UPWARD OR DOWNWARD ADJUSTMENT + 3mm

Using a 4 mm hex key, loosen / tighten the screws until you feel a slight pressure:

- Loosen by one turn, screws A and B
- Loosen by two turns, screws C
- Tighten screws D, alternating gradually on each hinge until desired position reached
- Tighten screws A and B
- Tighten screws C until you feel slight resistance
- Loosen and tighten screws D until you feel a slight resistance

SIDE AND DEPTH ADJUSTMENT ± 2mm

Use 4 mm hexagonal wrench

- On the hinge part fixed on sash, adjust alternately on screws F

DEPTH ADJUSTMENT ± 1mm

- On the hinge part fixed on frame, adjust alternately on screws D, then tighten

Do same adjustment to all hinges, to not twist the door.

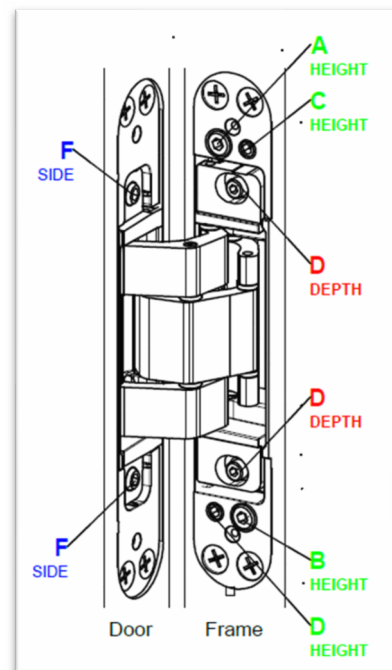

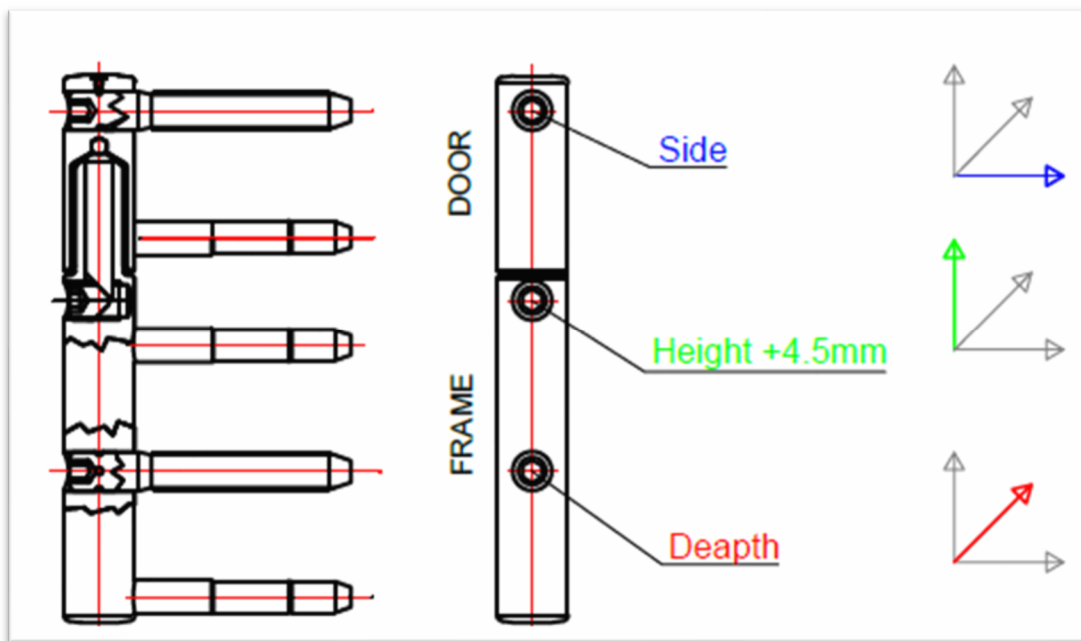
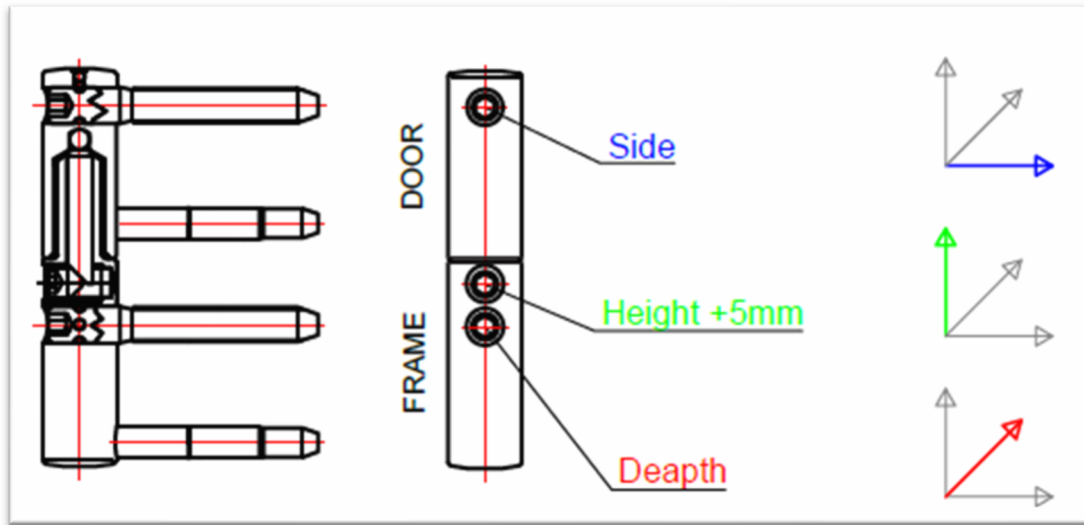

15.7 Lubrication

IMPORTANT: Review Chapter 5 before reading the supplemental information below.

Do not lubricate the hinges on a CAL door which are specially designed with encased lubricant.

Use lithium grease to lubricate the locking assembly.



For more information watch this short video on VETTA's YouTube channel.

[How To – Install a Danalock on a Cal Entry Door](#)

[How it works – Security locking hardware on a CAL Door](#)

[How To - make pressure adjustments on a CAL Door](#)

[How To - make door lock assembly adjustments on a CAL Door](#)

[How To - Lubricate CAL Door locking assembly](#)

[How To - Adjust CAL Door Hinges](#)

[How To – Install an AXA CAL Door Handle Set](#)